

12-BIT BINARY A/D CONVERTER

DESCRIPTION The μPD7002 is a high performance, low power, monolithic CMOS A/D converter designed for microprocessor applications. The analog input voltage is applied to one of the four analog inputs. By loading the input register with the multiplexer channel and the desired resolution (8 or 12 bits) the integrating A/D conversion sequence is started. At the end of conversion \overline{EOC} signal goes low and if connected to the interrupt line of microprocessor it will cause an interrupt. At this point the digital data can be read in two bytes from the output registers. The μPD7002 also features a status register that can be read at any time.

- FEATURES**
- Single Chip CMOS LSI
 - Resolution: 8 or 12 Bits
 - 4 Channel Analog Multiplexer
 - Auto-Zeroscale and Auto-Fullscale Corrections without any External Components
 - High Input Impedance: 1000MΩ
 - Readout of Internal Status Register Through Data Bus
 - Single +5V Power Supply
 - Interfaces to Most 8-Bit Microprocessors
 - Conversion Speed: 5 ms
 - Power Consumption: 20 mW
 - Available in a 28 Pin Plastic Package

PIN CONFIGURATION

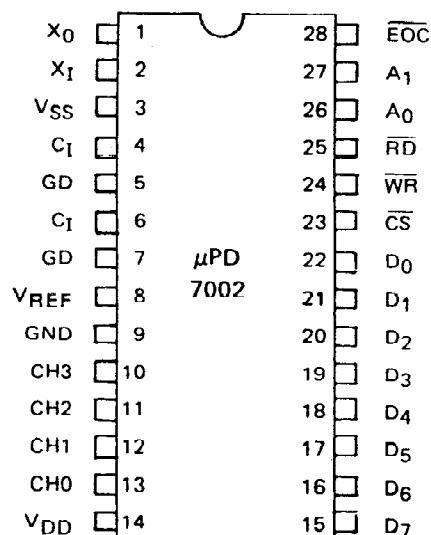

PIN NAMES

X ₀ , X ₁	External Clock Input
V _{SS}	TTL Ground
C ₁	Integrating Capacitor
GD	Guard
V _{REF}	Reference Voltage Input
GND	Analog Ground
CH3	Analog Channel 3
CH2	Analog Channel 2
CH1	Analog Channel 1
CH0	Analog Channel 0
V _{DD}	TTL Voltage (+5V)
D ₀ -D ₇	Data Bus
CS	Chip Select
\overline{WR} , \overline{RD}	Control Bus
A ₀ , A ₁	Address Bus
EOC	End of Conversion Interrupt

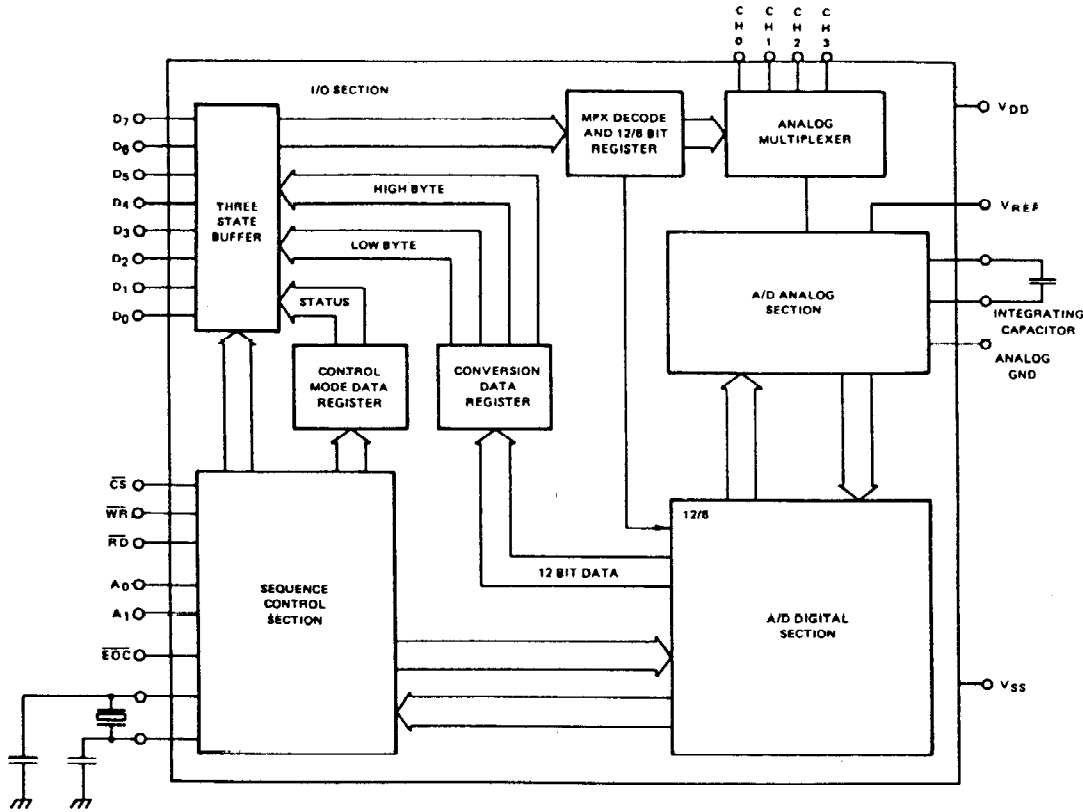

BLOCK DIAGRAM

DC CHARACTERISTICS

$T_a = 25 \pm 2^\circ\text{C}$; $V_{DD} = +5 \pm 0.25\text{V}$, $V_{REF} = +2.50\text{V}$, $f_{CK} = 1\text{MHz}$

PARAMETER	SYMBOL	LIMITS			UNIT	TEST CONDITIONS
		MIN	TYP	MAX		
Resolution			12		Bits	$V_{DD} = 5\text{V}$, $V_{REF} = 2.5 \pm 0.25\text{V}$
Non Linearity			0.05	0.08	%FSR	$V_{DD} = 5\text{V}$, $V_{REF} = 2.5 \pm 0.25\text{V}$
Fullscale Error			0.05	0.08	%FSR	$V_{DD} = 5\text{V}$, $V_{REF} = 2.5 \pm 0.25\text{V}$
Zeroscale Error			0.05	0.08	%FSR	$V_{DD} = 5\text{V}$, $V_{REF} = 2.5 \pm 0.25\text{V}$
Fullscale Temperature Coefficient			10		PPM/ $^\circ\text{C}$	$V_{DD} = 5\text{V}$
Zeroscale Temperature Coefficient			10		PPM/ $^\circ\text{C}$	$V_{DD} = 5\text{V}$
Analog Input Voltage Range	V_{IA}	0		V_{REF}	V	
Analog Input Resistance	R_{IA}		1000		M Ω	$V_{IA} = V_{SS}$ to V_{DD}
Total Unadjusted Error 1	T.U.E. 1		0.05	0.08	%FSR	$V_{REF} = 2.25$ to 2.75V , $V_{DD} = 5\text{V}$
Total Unadjusted Error 2	T.U.E. 2		0.05	0.08	%FSR	$V_{REF} = 2.5\text{V}$, $V_{DD} = 4.75$ to 5.25V
Clock Input Current	I_{X1}		5	50	μA	
Clock Input High Level	V_{XIH}	$V_{DD}-1.4$			V	
Clock Input Low Level	V_{XIL}			$V_{SS}+1.4$	V	
High Level Input Voltage	V_{IH}	2.2			V	$T_a = -20^\circ\text{C}$ to $+70^\circ\text{C}$
Low Level Input Voltage	V_{IL}			0.8	V	$T_a = -20^\circ\text{C}$ to $+70^\circ\text{C}$
High Level Output Voltage	V_{OH}	3.5			V	$I_O = -1.6\text{mA}$ $T_a = -20^\circ\text{C}$ to $+70^\circ\text{C}$
Low Level Output Voltage	V_{OL}			0.4	V	$I_O = +16\text{mA}$ $T_a = -20^\circ\text{C}$ to $+70^\circ\text{C}$
Digital Input Leakage Current	I_i		1	10	μA	$V_i = V_{SS}$ to V_{DD}
High-Z Output Leakage Current	I_{Leak}		1	10	μA	$V_O = V_{SS}$ to V_{DD}
Power Dissipation	P_d		15	25	mW	$f_{CK} < 1\text{MHz}$

μPD7002

ABSOLUTE MAXIMUM RATINGS*

Operating Temperature	-20°C to +70°C
Storage Temperature	-65°C to +125°C
All Input Voltages	-0.3 to V _{DD} + 0.3 Volts
Power Supply	-0.3 to +7 Volts
Power Dissipation	300 mW
Analog GND Voltage	V _{SS} ± 0.3 Volts

COMMENT: Stress above those listed under "Absolute Maximum Ratings" may cause permanent damage to the device. This is a stress rating only and functional operation of the device at these or any other conditions above those indicated in the operational sections of this specification is not implied. Exposure to absolute maximum rating conditions for extended periods may affect device reliability.

*T_a = 25°C

AC CHARACTERISTICS

T_a = 25° ± 2°C; V_{DD} = +5 ± 0.25V; V_{REF} = 2.5V; f_{CK} = 1 MHz; C_{INT} = 0.033 μF

PARAMETER	SYMBOL	LIMITS			UNIT	TEST CONDITIONS
		MIN	TYP	MAX		
Conversion Speed (12 bit)	t _{CONV}	8.5	10	15	ms	f _{CK} = 1 MHz
Conversion Speed (8 bit)	t _{CONV}	2.4	4	5	ms	f _{CK} = 1 MHz
Clock Frequency Range	f _{CK}	0.1	1	3	MHz	
Integrating Capacitor Value	C _{INT} *	0.029			μF	V _{REF} = 2.50V, f _{CK} = 1 MHz
Address Setup Time CS, A ₀ , A ₁ , to WR	t _{AW}	50			ns	
Address Setup Time CS, A ₀ , A ₁ , to RD	t _{AR}	50			ns	
Address Hold Time WR to CS, A ₀ , A ₁	t _{WA}	50			ns	
Address Hold Time RD to CS, A ₀ , A ₁	t _{RA}	50			ns	
Low Level WR Pulse Width	t _{WW}	400			ns	
Low Level RD Pulse Width	t _{RR}	400			ns	
Data Setup Time Input Data to WR	t _{DW}	300			ns	
Data Hold Time WR to Input Data	t _{WD}	50			ns	
Output Delay Time RD to Output Data	t _{RD}			300	ns	1TTL + 100 pF
Delay Time to High Z Output RD to Floating Output	t _{DF}			150	ns	

* C_{INT} (μF) (Min) = 0.029 / f_{CK} (MHz)

TIMING WAVEFORMS

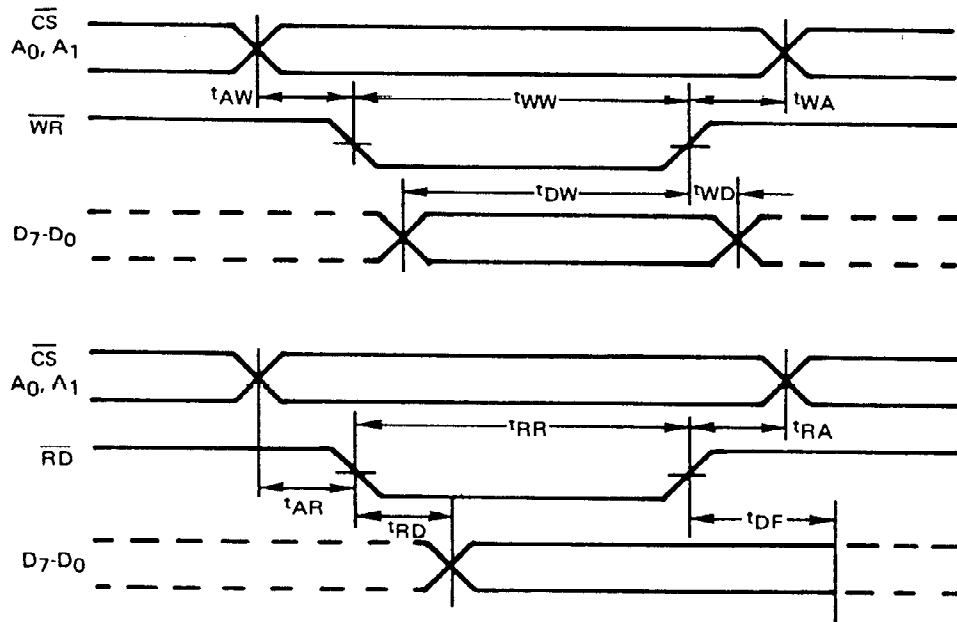

CONTROL TERMINAL FUNCTIONS

CONTROL TERMINALS					MODE	INTERNAL FUNCTION	DATA INPUT-OUTPUT TERMINALS
CS	RD	WR	A ₁	A ₀			
H	x	x	x	x	Not selected		High impedance
L	H	H	x	x	Not selected	—	
L	H	L	L	L	Write mode	Data latch A/D start	Input status, D ₁ , D ₀ = MPX address D ₃ = 8 bit/12 bit conversion designation. ① D ₂ = Flag Input
L	H	L	L	H	Not selected	—	High Impedance
L	H	L	H	L	Not selected	—	
L	H	L	H	H	Test mode	Test status	Input status ②
L	L	H	L	L	Read mode	Internal status	D ₇ = EOC, D ₆ = $\overline{\text{BUSY}}$, D ₅ = MSB, D ₄ = 2nd MSB, D ₃ = 8/12, D ₂ = Flag Output D ₁ = MPX, D ₀ = MPX
L	L	H	L	H	Read mode	High data byte	D ₇ -D ₀ = MSB - 8th bit
L	L	H	H	L	Read mode	Low data byte	D ₇ -D ₄ = 9th - 12th bit, D ₃ -D ₀ = L
L	L	H	H	H	Read mode	Low data byte	

Notes: ① Designation of number of conversion bits: 8 bit = L; 12 bit = H

② Test Mode: Used for inspecting the device. The data input-output terminals assume an input state and are connected to the A/D counter. Therefore, the A/D conversion data read out after this is meaningless.

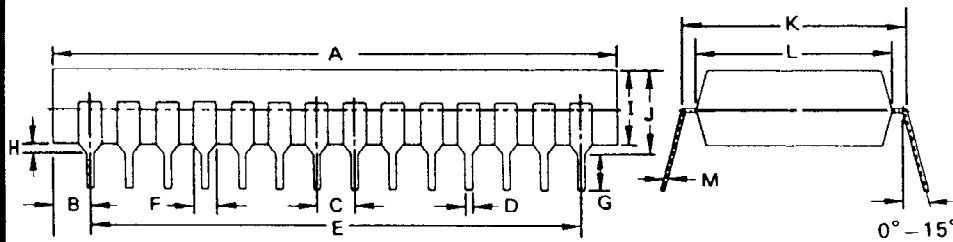

PACKAGE OUTLINE
μPD7002C

ITEM	MILLIMETERS	INCHES
A	38.0 MAX.	1.496 MAX.
B	2.49	0.098
C	2.54	0.10
D	0.5 ± 0.1	0.02 ± 0.004
E	33.02	1.3
F	1.5	0.059
G	2.54 MIN.	0.10 MIN.
H	0.5 MIN.	0.02 MIN.
I	5.22 MAX.	0.205 MAX.
J	5.72 MAX.	0.225 MAX.
K	15.24	0.6
L	13.2	0.52
M	0.25 + 0.10 - 0.05	0.01 + 0.004 - 0.002