Acorn Archimedes 500 series
Acorn R200 series
Service Manual

Copyright © Acorn Computers Limited 1991

Neither the whole nor any part of the information contained in, nor the product described in this manual may be adapted or reproduced in any material form except with the prior written approval of Acorn Computers Limited.

The products described in this manual, and products for use with it are subject to continuous development and improvement. All information of a technical nature and particulars of the products and their use (including the information and particulars in this manual) are given by Acorn Computers Limited in good faith. However, Acorn Computers Limited cannot accept any liability for any loss or damage arising from the use of any information or particulars in this manual, or any incorrect use of the products. All maintenance and service on the products must be carried out by Acorn Computers' authorised dealers or Approved Service Centres. Acorn Computers Limited can accept no liability whatsoever for any loss or damage caused by service, maintenance or repair by unauthorised personnel.

All correspondence should be addressed to:

The Customer Service department
Acorn Computers Limited
Fulbourn Road
Cherry Hinton
Cambridge CB1 4JN
United Kingdom

Support and information can also be obtained from the Acorn Support Information Database (SID). This is a Viewdata system available to registered SID users. Initially, access SID by dialling directly into the Guest User access (parity 7E1, speed V21/22/23/22bis, UK telephone number (0223) 243642): this will allow you to inspect the system and use a response frame for registration. Alternatively, access SID via Prestel (type *SID#): this will automatically register you on your first call.

ACORN, ARCHIMEDES, ARM and ECONET are trademarks of Acorn Computers Limited.

Epson is a trademark of Epson Corporation

Ethernet is a trademark of Xerox Corporation

Keytronic is a trademark of Keytronic Corporation

Olivetti is a trademark of Ing. C. Olivetti & Co.

Panasonic is a trademark of Panasonic U.K. Ltd

IBM is a trademark of International Business Machines Corporation.

Published by Acorn Computers Limited

ISBN 1 85250 093 X

Part number 0486,056

Issue 1, March 1991

Contents

About this manual	vi
Part 1 - System description	1-1
Introduction	1-1
General	1-1
System timing	1-2
The I/O system	1-3
The sound system	1-9
The keyboard and mouse	1-10
Floppy disc drive	1-14
Power supply	1-15
Hard disc drive	1-15
Main PCB Links	1-17
Plugs	1-18
Sockets	1-18
Internal expansion	1-19
Part 2 - Interface cards	2-1
Ethernet interface	2-1
Overview	2-1
Ethernet I expansion card	2-1
Ethernet II expansion card	2-13
SCSI interface	2-18
Part 3 - Disassembly and assembly	3-1
Introduction	3-1
Removing the top cover	3-1
Removing the SCSI podule	3-1
Removing cables	3-2
Removing the backplane	3-2
Removing the RAM and ARM cards	3-2
Removing the main PCB	3-2
Removing the front moulding assembly	3-2
Removing the floppy disc drive	3-2
Removing the hard disc drive	3-2
Removing the power supply unit	3-2
Main unit assembly	3-3
Keyboard	3-3
Mouse	3-3

Part 4 - Fault diagnosis	4-1
Test equipment required	4-1
Checking a 'dead' computer	4-2
Functional testing	4-4
General test procedure	4-4
Preparing to run the tests	4-5
Creating a CMOS test data file	4-6
Completing the tests	4-6
Main PCB functional test suite	4-7
Individual tests	4-15
Part 5 - Main PCB fault diagnosis	5-1
Test equipment you will need	5-1
Integral test software overview	5-1
Power-on self-test (POST)	5-1
Using the test link	5-3
Using the display adapter	5-4
Using the external diagnostic interface	5-9
Probe SWIs	5-17
Repairing a 'dead' computer	5-23
Test ROMs	5-23
Repairs following functional testing	5-27
Keyboard and mouse	5-28
Expansion cards	5-28
Part 6 - Parts lists	6-1
Main PCB assembly parts list	6-1
4MB RAM card (optional upgrade)	6-6
Backplane adaptor	6-6
ARM3 (PGA) Daughter card	6-7
Keyboard adaptor PCB (membrane keyboard)	6-7
Keyboard adaptor PCB (cont.) (membrane keyboard)	6-8
Keyboard assembly (keyswitch keyboard)	6-8
Ethernet I	6-8
Ethernet II	6-9
SCSI interface card (issue 2+)	6-10

Appendix A - Mouse test jig template	A-1
Appendix B - Ethernet test feedback leads	B-1
Appendix C - Serial port loopback plug	C-1
Appendix D - Earth continuity testing	D-1
Appendix E - DC Insulation testing - class 1	E-1

Drawings

- Final assembly drawings
- SCSI interface card circuit diagram
- Ethernet I expansion card circuit diagram
- Ethernet II expansion card circuit diagram
- Main PCB circuit diagram
- Main PCB assembly drawing
- 4MB RAM upgrade circuit diagram
- Backplane circuit diagram
- ARM3 (PGA) daughter card circuit diagram
- Keyboard adaptor PCB circuit diagram

About this manual

This manual is intended as a service manual for the following models:

- Archimedes 540
- Acorn R260
- Acorn R225

Throughout the remainder of this manual, the generic term *workstation* will be used to refer to the above, unless a reference to a specific model is required.

This manual supplements the basic information given on system hardware in the *Installation Guide* and *Technical Reference Manual* (available for separate purchase).

The operating systems, RISC OS and RISC iX, are covered at the user level in the *RISC OS User Guide* and the *RISC iX User Guide*, supplied with certain models (also available for separate purchase). Programmers and users requiring a greater depth of information about RISC OS and RISC iX will also need the following manuals:

- *RISC OS Programmer's Reference Manual*
(4 volume set)
- *RISC iX Programmer's Reference Manual*
(2 volume set).

They are available from Acorn authorised dealers.

Full details on the Acorn ARM chip set used in the workstation are given in the *Acorn RISC Machine (ARM) Family Data Manual*, ISBN 0-13-781618-9, available from:

VLSI Technology, Inc.
Application Specific Logic Products Division
8375 South River Parkway
Tempe, AZ 85284
USA
602-752-8574

or from the VLSI national distributor.

Note: This manual describes various PCB assemblies. The issue of each PCB is as defined by the relevant schematic.

Part 1 - System description

Introduction

The workstation is built around the ARM chip set, comprising the Acorn RISC Machine (ARM) itself, the Memory Controller (MEMC), Video Controller (VIDC) and Input Output Controller (IOC).

The ARM CPU is fitted on a daughter card. Additionally, memory expansion cards are available, each with 4MB of RAM and a MEMC controller.

A block diagram of the workstation is shown below:

General

The ARM3 CPU is a pipelined, 32-bit reduced instruction set microprocessor which accepts instructions and manipulates data via a high speed 32-bit data bus and 26-bit address bus, giving a 64 MB uniform address space. It supports virtual memory systems using a simple instruction set with good high-level language compiler support. The ARM3 version has 4KB of on-chip cache memory, which greatly increases data handling speeds (typically 2 - 3 times faster than ARM2).

Fig 1-1: Block diagram of workstation

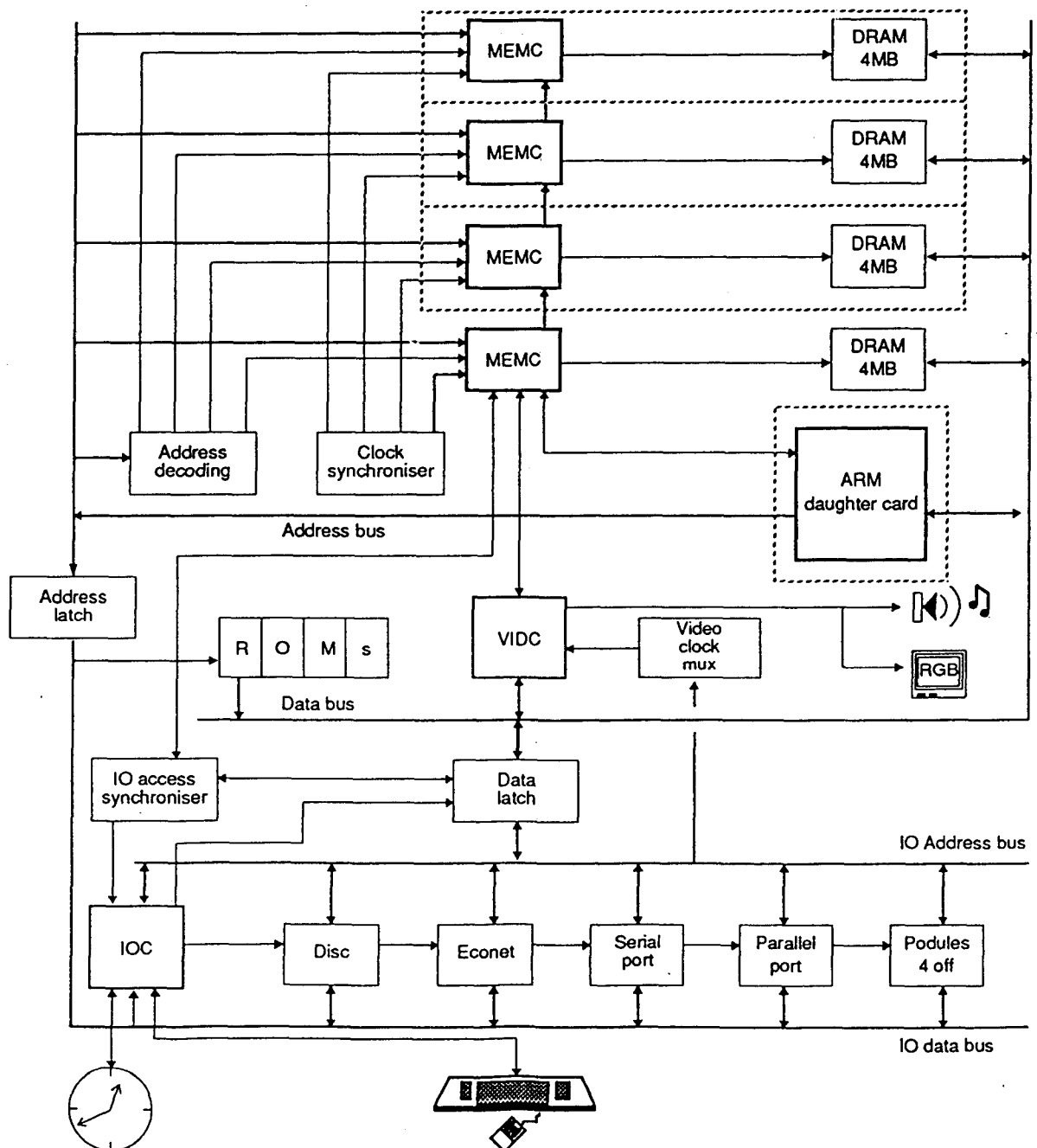

MEMC acts as the interface between the ARM, VIDC, IOC, ROM (Read-Only Memory) and DRAM (Dynamic RAM) devices, providing all the critical system timing signals, including processor clocks.

Up to 4 MB of DRAM is connected to the 'Master' MEMC which provides all signals and refresh operations. A Logical to Physical Translator maps the Physical Memory into a 32 MB Logical address space (with three levels of protection) allowing Virtual Memory and Multi-Tasking operations to be implemented. Fast page mode DRAM accesses are used to maximise memory bandwidth. VIDC requests data from the RAM when required and buffers it in one of three FIFOs before using it. Data is requested in blocks of four 32-bit words, allowing efficient use of paged-mode DRAM without locking the system data bus for long periods.

MEMC supports Direct Memory Access (DMA) operations with a set of programmable DMA Address Generators which provide a circular buffer for Video data, a linear buffer for Cursor data and a double buffer for Sound data.

IOC controls the I/O bus and expansion cards, and provides basic functions such as the keyboard interface, system timers, interrupt masks and control registers. It supports a number of different peripheral cycles and all I/O accesses are memory mapped.

VIDC takes video data from memory under DMA control, serialises it and passes it through a colour look-up palette and converts it to analogue signals for driving the CRT guns. VIDC also controls all the display timing

parameters and controls the position and pattern of the cursor sprite. In addition, it incorporates an exponential Digital to Analogue Converter (DAC) and stereo image table for the generation of high-quality sound from data in the DRAM.

VIDC is a highly programmable device, offering a very wide choice of display formats. The colour look-up palette which drives the three on-chip DACs is 13 bits wide, offering a choice from 4096 colours or an external video source.

The cursor sprite is 32 pixels wide and any number of rasters high. Three simultaneous colours (again from a choice of 4096) are supported and any pixel can be defined as transparent, making possible cursors of many shapes. It can be positioned anywhere on the screen.

The sound system implemented on the device can support up to eight channels, each with a separate stereo position.

Additional memory is provided on daughter cards, in 4MB blocks. Each 4MB block is controlled by a separate MEMC.

NOTE: MEMCs must be Acorn Part Number 2201,393, to ensure correct timing parameters.

System timing

Fig 1-2: System timing shows how the various clock signals are derived for the system.

Fig 1-2: System timing

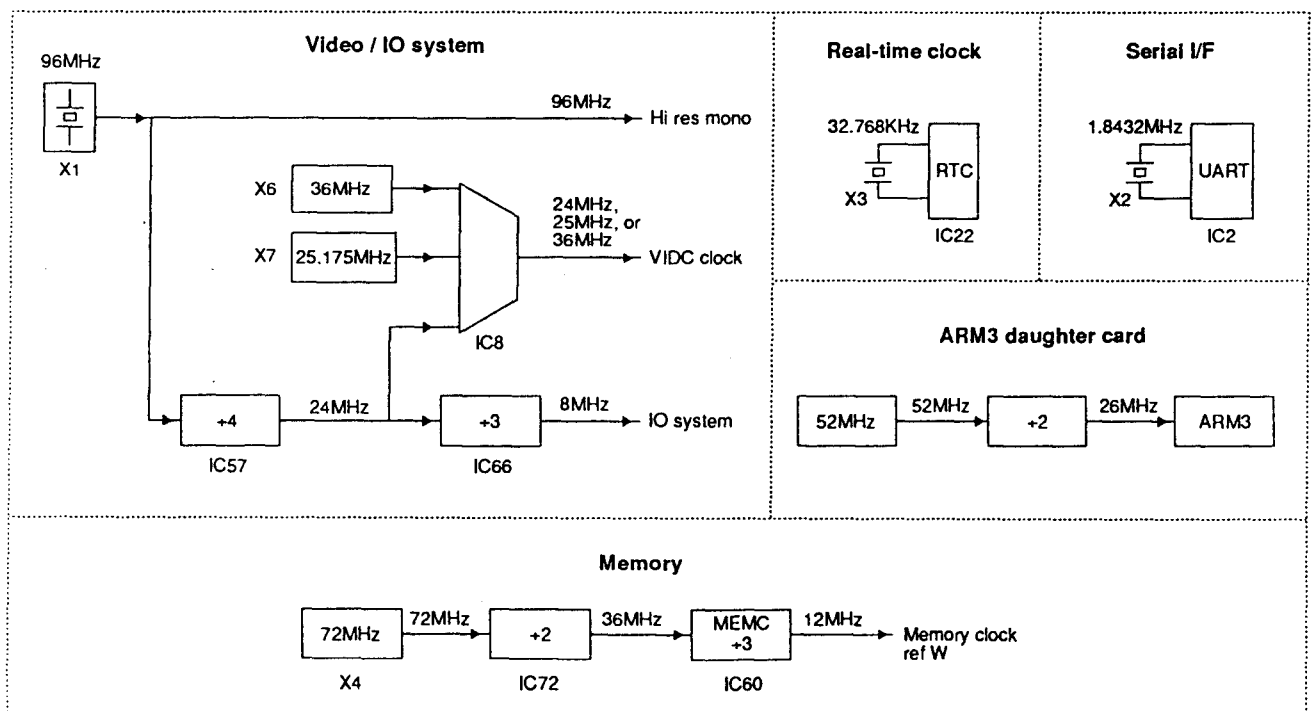

The I/O system

The I/O system is controlled by IOC, MEMC and two PALs. The I/O bus supports all the internal peripherals and the expansion cards.

This section is intended to give the reader a general understanding of the I/O system and should not be used to program the I/O system directly. The implementation details are liable to change at any time and only the published software interfaces should be used to manipulate the I/O system. Future systems may have a different implementation of the I/O system, and in particular the addresses (and number) of expansion card locations may move. For this reason, and to ensure that any device may be plugged into any slot, all driver code for expansion cards must be relocatable. References to the direct expansion card addresses should never be used. It is up to the machine operating system, in conjunction with the expansion card ID, to determine the address at which an expansion card should be accessed. To this extent, some of the following sections are for background information only.

System architecture

The I/O system (which includes expansion card devices) consists of a 16-bit data bus (BD[0:15]), a buffered address bus (LA[2:21]), and various control and timing signals. The I/O data bus is independent of the main 32-bit system data bus, being separated from it by bidirectional latches and buffers. In this way the I/O data bus can run at much slower speeds than the main system bus to cater for slower peripheral devices. The latches between the two buses, and hence the I/O bus timing, are controlled by the I/O controller, IOC. IOC caters for four different cycle speeds (slow, medium, fast and synchronous).

A typical I/O system is shown in *Fig 1-3: The I/O system*. For clarity, the data and address buses are omitted from this diagram.

System memory map

The system memory map is defined by master MEMC and the master PAL, and is shown in *Fig 1-4: System memory map*. Note that all system components, including I/O devices, are memory mapped.

I/O space memory map

This IOC-controlled space has allocation for simple expansion cards and MEMC expansion cards.

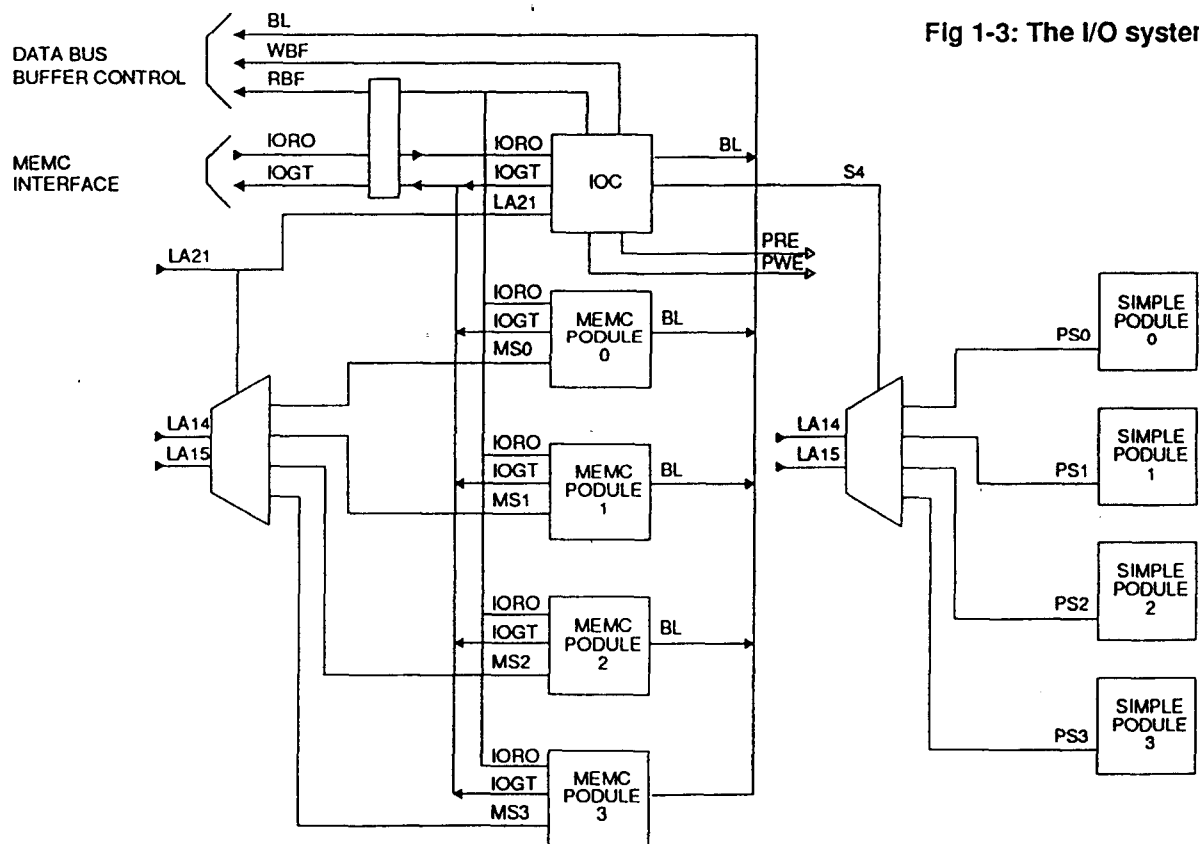

Fig 1-3: The I/O system

Data bus mapping

The I/O data bus is 16 bits wide. Byte-wide accesses are used for 8-bit peripherals. The I/O data bus (BD[0:15]) connects to the main system data bus (D[0:31]) via a set of bidirectional data latches.

The mapping of the BD[0:15] bus onto the D[0:31] bus is as follows:

During a WRITE (ie ARM to peripheral) D[16:31] is mapped to BD[0:15].

During a READ (ie peripheral to ARM) BD[0:15] is mapped to D[0:15].

Byte accesses

Byte instructions are used to access byte-wide expansion cards. A byte store instruction places the written byte on all four bytes of the word, and so correctly places the desired value on the lowest byte of the I/O bus. A byte or word load may be used to read a byte-wide expansion card into the lowest byte of an ARM register.

Half-word accesses

To access a 16-bit wide expansion card, half-word instructions are used. When storing, the half-word is placed on the upper 16 bits, D[16:31]. To maintain upwards compatibility with future machines, half-word stores replicate the written data on the lower half-word, D[0:15]. When reading, the upper 16 bits are undefined.

Expansion card identification

It is important that the system is able to identify what expansion cards (if any) are present, and where they are. This is done by reading the Podule (expansion card) Identification (PI) byte, or bytes, from the Podule Identification Field.

I/O address memory mapping

All I/O accesses are memory mapped. IOC is connected as detailed in this table:

IOC	ARM
OE	LA[21]
T[1]	LA[20]
T[0]	LA[19]
B[2]	LA[18]
B[1]	LA[17]
B[0]	LA[16]

Fig 1-4: System memory map

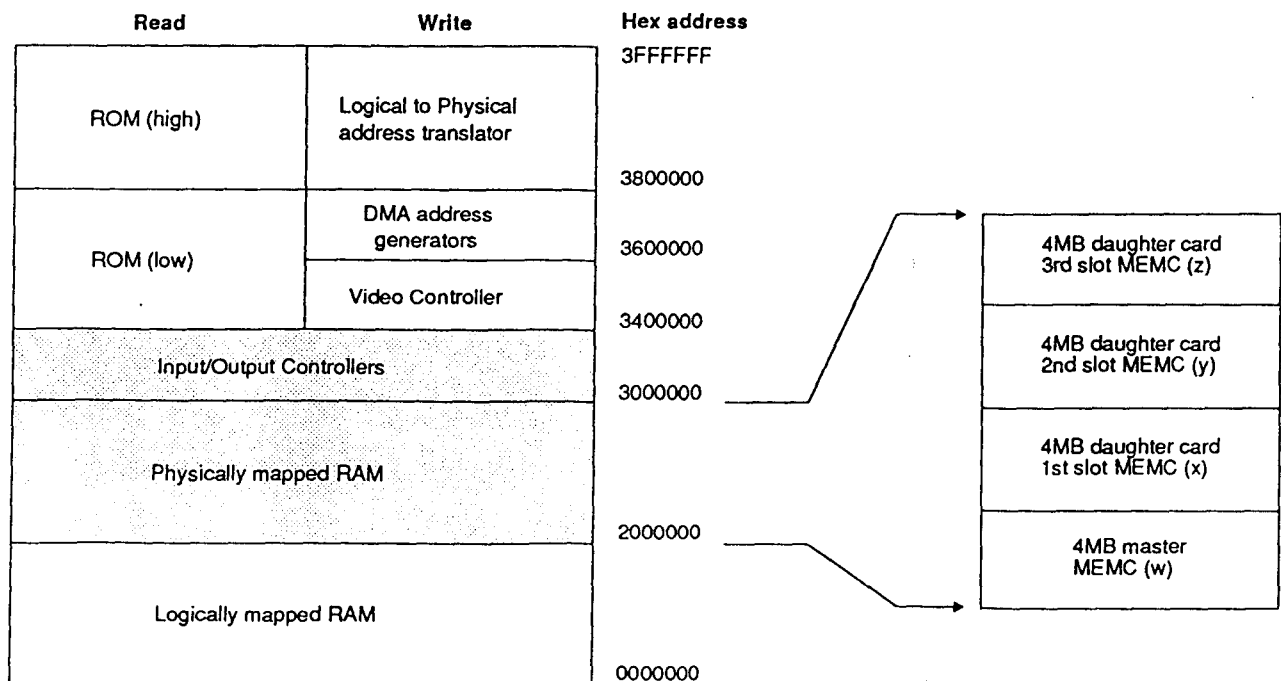

Internal register memory map

Address	Read	Write
3200000H	Control	Control
3200004H	Serial Rx Data	Serial Tx Data
3200008H	-	-
320000CH	-	-
3200010H	IRQ status A	-
3200014H	IRQ request A	IRQ clear
3200018H	IRQ mask A	IRQ mask A
320001CH	-	-
3200020H	IRQ status B	-
3200024H	IRQ request B	-
3200028H	IRQ mask B	IRQ mask B
320002CH	-	-
3200030H	FIQ status	-
3200034H	FIQ request	-
3200038H	FIQ mask	FIQ mask
320003CH	-	-
3200040H	T0 count Low	T0 latch Low
3200044H	T0 count High	T0 latch High
3200048H	-	T0 go command
320004CH	-	T0 latch command
3200050H	T1 count Low	T1 latch Low
3200054H	T1 count High	T1 latch High
3200058H	-	T1 go command
320005CH	-	T1 latch command
3200060H	T2 count Low	T2 latch Low
3200064H	T2 count High	T2 latch High
3200068H	-	T2 go command
320006CH	-	T2 latch command
3200070H	T3 count Low	T3 latch Low
3200074H	T3 count High	T3 latch High
3200078H	-	T3 go command
320007CH	-	T3 latch command

Peripheral address

Cycle type	Bk	Base address	IC	Use
Fast	1	&3310000	1772	Floppy disc controller
Sync	2	&33A0000	6854	Econet controller *
Sync	3	&33B0000	6551	Serial line controller
Slow	4	&3240000	Podule 0	Expansion slot
Med	4	&32C0000	Podule 0	Expansion slot
Fast	4	&3340000	Podule 0	Expansion slot
Sync	4	&33C0000	Podule 0	Expansion slot
Slow	4	&3244000	Podule 1	Expansion slot
Med	4	&32C4000	Podule 1	Expansion slot
Fast	4	&3344000	Podule 1	Expansion slot
Sync	4	&33C4000	Podule 1	Expansion slot
Slow	4	&3248000	Podule 2	Expansion slot
Med	4	&32C8000	Podule 2	Expansion slot
Fast	4	&3348000	Podule 2	Expansion slot
Sync	4	&33C8000	Podule 2	Expansion slot
Slow	4	&324C000	Podule 3	Expansion slot
Med	4	&32CC000	Podule 3	Expansion slot
Fast	4	&334C000	Podule 3	Expansion slot
Sync	4	&33CC000	Podule 3	Expansion slot
Fast	5	&3350000	LS374	Printer Data
Fast	5	&3350018	HC574	Latch B (See next page for details)
Fast	5	&3350040	HC574	Latch A (See next page for details)
Fast	5	&3350048	HC175	Latch C (See next page for details)
Fast	6	&3360000	16L8	Podule interrupt request register
Fast	6	&3360004	16L8	Podule interrupt mask register
Slow	7	&3270000		Extended external podule space

*if fitted

I/O programming details

External latch A

External latch A is a write only latch used to control parts of the floppy disc sub-system:

Bit	Name	Function
0-3	Floppy disc sel.	These bits select the floppy disc drive 0 through 3 when written LOW. Only one bit should be LOW at any one time.
4	Side select	This controls the side select line of the floppy disc interface. 0 = Side 1 (upper) 1 = Side 0 (lower)
5	Floppy motor	This bit controls the floppy disc on/off control motor line. Its exact use depends on the type of drive.
6	In Use	This bit controls the IN USE line of the floppy disc. Its exact use depends on the type of drive.
7		Not used.

External latch B

External Latch B is a write only register shared between several users who must maintain a consistent RAM copy. Updates must be made with IRQ disabled.

Bit	Name	Function
0-2		CD[0:2] should be programmed CD[0:2] LOW for future compatibility. CD[1] controls the floppy disc data separator format. CD[1] = 0 Double Density CD[1] = 1 Single Density
3	FDCR	This controls the floppy disc controller reset line. When programmed LOW, the controller is RESET.
4	Printer Strobe	This is used to indicate valid data on the printer outputs. It should be set HIGH when valid data has been written to the printer port and LOW after about 5
[5:6]	AUX [1:2]	Not used.
7	HS3	Not used.

External latch C

External latch C is a write only register that is used to control video sync polarity and clock speed.

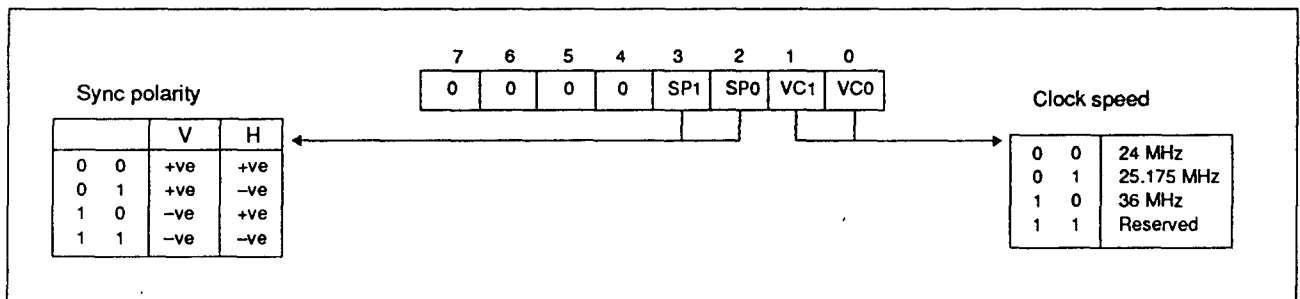

Interrupts

The I/O system generates two independent interrupt requests, IRQ and FIQ. Interrupt requests can be caused by events internal to IOC or by external events on the interrupt or control port input pins.

The interrupts are controlled by four types of register:

- status
- mask
- request
- clear

The status registers reflect the current state of the various interrupt sources. The mask registers determine which sources may generate an interrupt. The request registers are the logical AND of the status and mask registers and indicate which sources are generating interrupt requests to the processor. The clear register allows clearing of interrupt requests where appropriate. The mask registers are undefined after power up.

The IRQ events are split into two sets of registers, A and B. There is no priority encoding of the sources.

Internal Interrupt Events

- Timer interrupts TM[0:1]
- Power-on reset POR
- Keyboard Rx data available SRx
- Keyboard Tx data register empty STx
- Force interrupts 1.

External Interrupt Events

- IRQ active low inputs IL[0:7] wired as (0-7 respectively) PFIQ, SIRQ, SLC1, not used, DCIRQ, PIRQ, PBSY and RII.
- IRQ falling-edge input IF wired as PACK
- IRQ rising-edge input IR wired as VFLY
- FIQ active high inputs FII[0:1] wired as FFDQ and FFIQ
- FIQ active low input FL wired as EFIQ
- Control port inputs C[3:5].

Podule interrupt mask

Podule IRQ can be masked by writing a 0 to the Podule IRQ mask register at &3360004. This will disable the interrupt.

The request register at &3360000 is a logical AND of Podule IRQ and the mask register, ie it is 1 if Podule IRQ is not masked.

IRQ status A

Bit	Name	Function
0	PBSY	This bit indicates that the printer is busy.
1	RI	This bit indicates that a Ringing Indication has been detected by the serial line interface.
2	Printer Ack	This bit indicates that a printer acknowledgement bit has been received.
3	Vertl Flyback	This bit indicates that a vertical flyback has commenced.
4	Power-on reset	This bit indicates that a power-on reset has occurred.
[5:6]	Timer 0 and Timer 1 events	These bits indicate that events have occurred. Note: latched interrupt.
7	Force	This bit is used to force an IRQ request. It is usually owned by the FIQ owner

IRQ status B

Bit	Name	Function
0	Podule FIQ req	This bit indicates that a Podule FIQ request has been received. It should usually be masked OFF.
1	Snd buffr swap	This bit indicates that the MEMC sound buffer pointer has been relocated.
2	Serial line ctrlr	This bit indicates that 65C51 serial line controller interrupt has occurred.
3	H disc interrupt	This bit indicates that a hard disc interrupt has occurred.
4	Disc changed	This bit indicates that the floppy disc interrupt has been removed.
5	Pod. interr req	This bit indicates that a Podule IRQ request has occurred.
6	Keyb Tx event	This bit indicates that the keyboard transmit register is empty and may be reloaded.
7	Keybd Rx event	This bit indicates that the keyboard reception register is full and may be read.

Interrupt status FIQ

Bit	Name	Function
0	Floppy disc data request	This bit indicates that a floppy disc Data Request has occurred.
1	Floppy disc interrupt request	This bit indicates that a floppy disc Interrupt Request has occurred.
2	Econet Interrupt request	This bit indicates that an Econet Interrupt Request has occurred.
3-5	C[3:5]	See IOC data sheet for details.
6	Podule FIQ req	This bit indicates that a podule FIQ Request has occurred.
7	Force	This bit allows an FIQ Interrupt Request to be generated.

Control port

The control register allows the external control pins C[0:5] to be read and written and the status of the PACK and VFLY inputs to be inspected. The C[0:5] bits manipulate the C[0:5] I/O port. When read, they reflect the current state of these pins. When written LOW the output pin is driven LOW. These outputs are open-drain, and if programmed HIGH the pin is undriven and may be treated as an input.

On reset all bits in the control register are set to 1.

Bit	Name	Function
C[7]	VFLYBK	Allows the state of the (VFLYBK) and Test Mode signal to be inspected. This bit will be read HIGH during vertical flyback and LOW during display. See VIDC datasheet for details. This bit MUST be programmed HIGH to select normal operation of the chip.
C[6]	PACK & Test Mode	Allows the state of the parallel printer acknowledge input to be inspected. This bit MUST be programmed HIGH to select normal operation of the chip.
C[5]	SMUTE	This controls the muting of the internal speaker. It is programmed HIGH to mute the speaker and LOW to enable it. The speaker is muted on reset.
C[4]		Available on the Auxiliary I/O connector.
C[3]		Programmed HIGH, unless Reset Mask is required.
C[2]	READY	Used as the floppy disc (READY) input and must be programmed HIGH.
C[1:0]	SDA, SCL	The C[0:1] pins are used to implement the I2C bus the bi-directional serial I2C bus to which the Real Time Clock and battery-backed RAM are connected.

The sound system

The sound system is based on the VIDC stereo sound hardware. External analogue anti-alias filters are used which are optimised for a 20 kHz sample rate. The high quality sound output is available from a 3.5mm stereo jack socket at the rear of the machine which will directly drive personal stereo headphones or alternatively an amplifier and speakers. One internal speaker is fitted, to provide mono audio.

VIDC sound system hardware

VIDC contains an independent sound channel consisting of the following components: A four-word FIFO buffers 16 8-bit sound samples with a DMA request issued whenever the last byte is consumed from the FIFO. The sample bytes are read out at a constant sample rate programmed into the 8-bit Audio Frequency Register. This may be programmed to allow samples to be output synchronously at any integer value between 3 and 255 microsecond intervals.

The sample data bytes are treated as sign plus 7-bit logarithmic magnitude and, after exponential digital to analogue conversion, de-glitching and sign-bit steering, are output as a current at one of the audio output pins to be integrated and filtered externally.

VIDC also contains a bank of eight stereo image position registers each of three bits. These eight registers are sequenced through at the sample rate with the first register synchronised to the first byte clocked out of the FIFO. Every sample time is divided into eight time slots and the 3-bit image value programmed for each register is used to pulse width modulate the output amplitude between the LEFT and RIGHT audio current outputs in multiples of time slot subdivisions. This allows the signal to be spatially positioned in one of seven stereo image positions.

MEMC sound system hardware

MEMC provides three internal DMA address registers to support Sound buffer output; these control the DMA operations performed following Sound DMA requests from VIDC. The registers allow the physical addresses for the START, PNTR (incremental) and END buffer pointers to a block of data in the lowest half Megabyte of physical RAM to be accessed. These operate as follows: programming a 19-bit address into the PNTR register sets the physical address from which sequential DMA reads will occur (in multiples of four words), and programming the END pointer sets the last physical address of the buffer. Whenever the PNTR register increments up to this END value the address programmed into the START register is automatically written into the PNTR register for the DMA to continue with a new sample buffer in memory.

A Sound Buffer Interrupt (SIRQ) signal is generated when the reload operation occurs which is processed by IOC as a maskable interrupt (IRQ) source.

MEMC also includes a sound channel enable/disable signal. Because this enable/disable control signal is not synchronised to the sound sampling, requests will normally be disabled after the waveforms which are being synthesised have been programmed to decay to zero amplitude; the last value loaded into the Audio data latch in the VIDC will be output to each of the Stereo image positions at the current Audio Sample rate.

IOC sound system hardware

IOC provides a programmed output control signal which is used to turn the internal speaker on or off, as well as an interrupt enable/status/reset register interface for the Sound Start Buffer reload signal generated by MEMC.

The internal speaker may be muted by the control line SMUTE which is driven from the IOC output C5. On reset this signal will be taken high and the internal speaker will be muted.

The stereo output to the headphone socket is not muted by SMUTE and will always reflect the current output of the DAC channels.

The keyboard and mouse

The keyboard assembly comprises a membrane keyswitch panel connected to an adaptor PCB, which serialises the keyboard and mouse data; connection to the ARM is made via a serial link to the IOC. The ARM reads and writes to the KART registers in the IOC. The protocol is essentially half duplex, so in normal operation the keyboard will not send a second byte until it has received an Ack. The only exception to this is during the reset protocol used to synchronise the handshaking, where each side is expecting specific responses from the other, and will not respond further until it has these.

In addition to this simple handshaking system, the keyboard will not send mouse data unless specifically allowed to, as indicated by Ack Mouse, which allows the transmission of one set of accumulated mouse coordinate changes, or the next move made by the mouse. While it is not allowed to send mouse changes, the keyboard will buffer mouse changes.

A similar handshake exists on key changes, transmitted as key up and key down, and enabled by Ack Scan. At the end of a keyboard packet (two bytes) the operating system will perform an Ack Scan as there is no protocol for re-enabling later. Mouse data may be requested later by means of Request Mouse Position (RQMP).

Key codes

The keyboard identifies each key by its row and column address in the keyboard matrix. Row and column codes are appended to the key up or down prefix to form the complete key code.

For example, Q key down – the complete row code is 11000010 (&C2) and the column code is 11000111 (&C7).

Note: Eight keys have N key roll over. The operating system is responsible for implementing two-key rollover, therefore the keyboard controller transmits all key changes (when enabled). The keyboard does not operate any auto-repeat; only one down code is sent, at the start of the key down period.

Data protocol

Data transmissions from the keyboard are either one or two bytes in length. Each byte sent by the keyboard is individually acknowledged. The keyboard will not transmit a byte until the previous byte has been acknowledged, unless it is the HRST (HardReSeT) code indicating that a power on or user reset occurred or that a protocol error occurred; see paragraph below.

Reset protocol

The keyboard restarts when it receives an HRST code from the ARM. To initiate a restart the keyboard sends an HRST code to the ARM, which will then send back HRST to command a restart.

The keyboard sends HRST to the ARM if:

- A power-on reset occurs
- A user reset occurs
- A protocol error is detected.

After sending HRST, the keyboard waits for an HRST code. Any non-HRST code received causes the keyboard to resend HRST. The pseudo program on this page illustrates the reset sequence or protocol.

Note, the on/off state of the LEDs does not change across a reset event, hence the LED state is not defined at power on. The ARM is always responsible for selecting

```
START reset
ONerror Send HRST code to ARM then wait for code from ARM.
IF code = HRST THEN restart ELSE error
ONrestart clear mouse position counters
          set mouse mode to data only in response to an RMPS request.
          stop key matrix scanning and set key flags to up
          send HRST code to ARM

Wait for next code
IF code = RAK1 THEN send RAK1 to ARM ELSE error
Wait for next code
IF code = RAK2 THEN send RAK2 to ARM ELSE error
Wait for next code
IF code = SMAK THEN mouse mode to send if not zero and enable key scan
ELSE IF code = SACK THEN enable key scanning
ELSE IF code = MACK THEN set mouse mode to send when not zero
ELSE IF code = NACK THEN do nothing ELSE error
END reset
```

Reset sequencing

Direction	Code	Expected reply	Action on wrong reply (Sender)	Action on timeout (Sender)	Action if unexpected (Receiver)
ARM -> Kb	Hard reset	Hard reset	Resend	Resend	Hard reset
Kb -> ARM	Hard reset	Reset Ack 1	Resend	Nothing	Hard reset
ARM -> Kb	Reset Ack 1	Reset Ack 1	Hard reset	Hard reset	Hard reset
Kb -> ARM	Reset Ack 1	Reset Ack 2	Nothing	Nothing	Hard reset
ARM -> Kb	Reset Ack 2	Reset Ack 2	Hard reset	Hard reset	Hard reset

the LED status. After the reset sequence, key scanning will only be enabled if a scan enable acknowledged (SACK or SMAK) was received from the ARM.

Data transmission

When enabled for scanning, the keyboard controller informs the ARM of any new key down or new key up by sending a two byte code incorporating the key row and column addresses. The first byte gives the row and is acknowledged by a byte acknowledge (BACK) code from the ARM. If BACK was not the acknowledge code then the error process (ON error) is entered. If the BACK code was received, the keyboard controller sends the column information and waits for an acknowledge. If either a NACK, SACK, MACK or SMAK acknowledge code is received, the keyboard controller continues by processing the ACK type and selecting the mouse and scan modes implied. If the character received as the second byte acknowledge was not one of NACK/MACK/SACK/SMAK then the error process is entered.

Mouse data

Mouse data is sent by the keyboard controller if requested by a RQMP request from the ARM or if a SMAK or MACK has enabled transmission of non-zero values. Two bytes are used for mouse position data. Byte one encodes the accumulated movement along the X axis while byte two gives Y axis movement.

Both X and Y counts must be transferred to temporary registers when data transmission is triggered, so that accumulation of further mouse movement can occur. The

X and Y counters are cleared upon each transfer to the transmit holding registers. Therefore, the count values are relative to the last values sent. The ARM acknowledges the first byte (Xcount) with a BACK code and the second byte (Ycount) with any of NACK/MACK/SACK/SMAK. A protocol failure causes the keyboard controller to enter the error process (ON error). When transmission of non-zero mouse data is enabled, the keyboard controller gives key data transmission priority over mouse data except when the mouse counter over/underflows.

Acknowledge codes

There are seven acknowledge codes which may be sent by the ARM. RAK1 and RAK2 are used during the reset sequence. BACK is the acknowledge to the first byte of a 2-byte keyboard data set. The four remaining types, NACK/MACK/SACK and SMAK, acknowledge the final byte of a data set. NACK disables key scanning and therefore key up/down data transmission as well as setting the mouse mode to send data only on RQMP request. SACK enables key scanning and key data transmission but disables unsolicited mouse data. MACK disables key scanning and key data transmission and enables the transmission of mouse count values if either X or Y counts are non-zero. SMAK enables key scanning and both key and mouse data transmission. It combines the enable function of SACK and MACK.

While key scanning is suspended (after NACK or MACK) any new key depression is ignored and will not result in a key down transmission unless the key remains down after scanning resumes following a SACK or SMAK.

Code values

Mnemonic	msb	lsb	Comments
HRST	1111	1111	1-byte command, keyboard reset.
RAK1	1111	1110	1-byte response in reset protocol.
RAK2	1111	1101	1-byte response in reset protocol.
RQPD	0100	xxxx	1-byte from ARM, encodes four bits of data.
PDAT	1110	xxxx	1-byte from keyboard, echoes four data bits of RQPD.
RQID	0010	0000	1-byte ARM request for keyboard ID.
KBID	10xx	xxxx	1-byte from keyboard encoding keyboard ID.
KDDA	1100	xxxx	New key down data. Encoded Row (first byte) and column (second byte) numbers.
KUDA	1101	xxxx	Encoded Row (first byte) and column (second byte) numbers for a new key up.
RQMP	0010	0010	1-byte ARM request for mouse data.
MDAT	0xxx	xxxx	Encoded mouse count, X (byte1) then Y (byte2). Only from ARM to keyboard.
BACK	0011	1111	Ack for first keyboard data byte pair.
NACK	0011	0000	Last data byte Ack, selects scan/mouse mode.
SACK	0011	0001	Last data byte Ack.
MACK	0011	0010	Last data byte Ack.
SMAK	0011	0011	Last data byte Ack.
LEDS	0000	0xxx	bit flag to turn LED(s) on/off.
PRST	0010	0001	From ARM, 1-byte command, does nothing.

x is a data bit in the Code; e.g. xxxx is a four bit data field

Similarly, a key release is ignored while scanning is off. Commands may be received at any time. Therefore, commands can be interleaved with acknowledge replies from the ARM, eg keyboard sends KDDA (first byte), keyboard receives command, keyboard receives BACK, keyboard sends KDDA (second byte), keyboard receives command, keyboard receives SMACK. If the HRST command is received the keyboard immediately enters the restart sequence. The LEDS and PRST commands may be acted on immediately. Commands which require a response are held pending until the current data protocol is complete. Repeated commands only require a single response from the keyboard.

ARM commands

Mnemonic	Function
HRST	Reset keyboard.
LEDS	Turns key cap LEDs on/off. A three bit field indicates which state the LEDs should be in. Logic 1 is ON, logic 0 (zero) OFF. D0 controls CAPS LOCK D1 controls NUM LOCK D2 controls SCROLL LOCK
RQM	Request mouse position (X,Y counts).
RQID	Request keyboard identification code. The computer is manufactured with a 6-bit code to identify the keyboard type to the ARM. Upon receipt of RQID the keyboard controller transmits KBID to the ARM.
PRST	Reserved for future use, the keyboard controller currently ignores this command.
RQPD	For future use. The keyboard controller will encode the four data bits into the PDAT code data field and then send PDAT to the ARM.

Mouse interface

The mouse interface has three switch sense inputs and two quadrature encoded movement signals for each of the X axis and Y axis directions. Mouse key operations are debounced and then reported to the ARM using the Acorn key up / key down protocol. The mouse keys are allocated unused row and column codes within the main key matrix.

Switch 1 (left)	Row code - 7	Column code - 0
Switch 2 (middle)	Row code - 7	Column code - 1
Switch 3 (right)	Row code - 7	Column code - 2

For example, switch 1 release would give 11010111 (&D7) as the complete row code, followed by 11010000 (&D0) for the column code.

Note: Mouse keys are disabled by NACK and MACK acknowledge codes, and are only enabled by SACK and SMAK codes, ie they behave in the same way as the keyboard keys.

The mouse is powered from the computer 5V supply and may consume up to 100mA.

Movement signals

Each axis of movement is independently encoded in two quadrature signals. The two signals are labelled REFerence and DIRection (eg X REF and X DIR). The table below defines the absolute direction of movement. Circuitry in the keyboard decodes the quadrature signals and maintains a signed 7-bit count for each axis of mouse movement.

Initial state		Next state		
REF	DIR	REF	DIR	
1	1	1	0	Increase count by one for each change of state.
1	0	0	0	
0	0	0	1	
0	1	1	1	
1	1	0	1	Decrease count by one for each change of state.
0	1	0	0	
0	0	1	0	
1	0	1	1	

When count overflow or underflow occurs on either axis both X and Y axis counts lock and ignore further mouse movement until the current data has been sent to the ARM.

Overflow occurs when a counter holds its maximum positive count (0111111 binary). Underflow occurs when a counter holds its maximum negative count (1000000 binary).

Base Keyswitch mapping (UK 103 key keyboard)

Key size	Key name	Row code	Col. code	Notes
1	Esc	0	0	1
1	F1	0	1	2
1	F2	0	2	2
1	F3	0	3	2
1	F4	0	4	2
1	F5	0	5	2
1	F6	0	6	2
1	F7	0	7	2
1	F8	0	8	2
1	F9	0	9	2
1	F10	0	A	2
1	F11	0	B	2
1	F12	0	C	2
1	Print	0	D	1,3
1	Scroll	0	E	1
1	Break	0	F	1
1	~	1	0	
1	1	1	1	
1	2	1	2	
1	3	1	3	
1	4	1	4	
1	5	1	5	
1	6	1	6	
1	7	1	7	
1	8	1	8	
1	9	1	9	
1	0	1	A	
1	-_	1	B	
1	=+	1	C	
1	£¤	1	D	
1	Backspc	1	E	1
1	Insert	1	F	1
1	Home	2	0	1,3
1	Pgup	2	1	1
1	Numlock	2	2	1,4
1	/	2	3	1
1	*	2	4	1
1	#	2	5	1

Key size	Key name	Row code	Col. code	Notes
1.5	Tab	2	6	1
1	Q	2	7	
1	W	2	8	
1	E	2	9	
1	R	2	A	
1	T	2	B	
1	Y	2	C	
1	U	2	D	
1	I	2	E	
1	O	2	F	
1	P	3	0	
1	[[3	1	
1]]	3	2	
1.5	\	3	3	
1	Delete	3	4	1
1	Copy	3	5	1
1	Pgdown	3	6	1
1	7	3	7	
1	8	3	8	
1	9	3	9	
1	-	3	A	1
1.75	Ctrl	3	B	1,3
1	A	3	C	
1	S	3	D	
1	D	3	E	
1	F	3	F	
1	G	4	0	
1	H	4	1	
1	J	4	2	
1	K	4	3	
1	L	4	4	
1	::	4	5	
1	,"	4	6	
2.25	Return	4	7	1
1	4	4	8	
1	5	4	9	
1	6	4	A	
1	+	4	B	1

Row and column codes are in hexadecimal.

Notes: 1 Key colour - dark grey.
 2 Key colour - dark grey.
 3 Key position with N key rollover.
 4 Green LED under key cap.

Keyswitch mapping (cont.)

Key Size	Key Name	Row code	Col. code	Notes
2.25	shift	4	C	1,3
1	Z	4	E	
1	X	4	F	
1	C	5	0	
1	V	5	1	
1	B	5	2	
1	N	5	3	
1	M	5	4	
1	.<	5	5	
1	.>	5	6	
1	/	5	7	
2.75	shift	5	8	1,3
1	crsrUp	5	9	1
1	1	5	A	
1	2	5	B	
1	3	5	C	
1.5	Caps	5	D	1,4
1.5	Alt	5	E	1,3
7.0	Space	5	F	
1.5	Alt	6	0	1,3
1.5	Ctrl	6	1	1,3
1	crsrLt	6	2	1
1	crsrDn	6	3	1
1	crsrRt	6	4	1
2.0	0	6	5	
1	.	6	6	
2.0	Enter	6	7	1

Row and column codes are in hexadecimal.		
Notes:	1	Key colour - dark grey.
	2	Key colour - dark grey.
	3	Key position with N key rollover.
	4	Green LED under key cap.

Floppy disc drive

The floppy disc drive used on the workstations (except discless) is a one-inch high drive, taking 3.5 inch double-sided double-density floppy discs.

Performance

Capacity	1 MB (unformatted)
Track to track step rate	3ms
Seek settle time	15ms
Write to read timing	1200µs
Power-on to drive ready	1000ms
Power supply	+5Vdc (+/- 5%)
Maximum power	2 Watts (continuous)

Power connector

The power connector is a 4-pin, 2.5mm pitch type.

Pin	Signal
1	+5V
2	0V
3	0V
4	+12V

Interface connector

The interface connector is a 34-way, 2 row, 0.1 inch pitch type, with pinouts as shown below:

Pin		Signal	Dir main (PCB)
Retn	Signal		
1	2	Disc change	I
3	4	In use	I
5*	6	Drive select 3	O
7*	8	Index	I
9*	10	Drive select 0	O
11*	12	Drive select 1	O
13	14	Drive select 2	O
15	16	Motor ON	O
17	18	Direction	O
19	20	Step/Disc chg rst	O
21	22	Write data	O
23	24	Write gate	O
25	26	Track 0	I
27	28	Write protect	I
29	30	Read data	I
31	32	Side 1 select	O
33	34	Ready	I

*Optionally +5V I = Input O = Output

Power supply

Performance characteristics

Performance	Min	Nom	Max	Units
Input voltage (47-53 Hz)	198	220/ 240	264	Vac
*Input voltage (57-63 Hz)	98	110	132	Vac
Output voltage VO1	4.9	5	5.1	Vdc
Output current IO1	1.5	-	12.2	Amps dc
Output ripple and noise VO1			50	mV pk-pk BW 0-20MHz
Overshoot VO1			0.1	Vdc
Overvoltage prot VO1 (thrshld)	5.8	-	7.0	Vdc
Surge output current IO1	-	-	14.5	Amps dc
Surge output current duration	-	-	1.0	Sec
Output voltage VO2	11.4	12	12.6	Vdc
Output current IO2	0	-	3.2	Amps dc
Output ripple and noise VO2			100	mV pk-pk BW 0-20 MHz
Overshoot VO2			0.2	Vdc
Surge output current IO2	-	-	4	Amps dc
Surge output current duration	-	-	10.0	Sec
Output voltage VO3	-4.5	-5	-5.5	Vdc
Output current IO3	0	-	0.3	Amps dc
Output ripple and noise VO3			50	mV pk-pk BW 0-20MHz
Overshoot VO3			0.1	Vdc
Efficiency	63	-	-	%@max ld, nominal VP volt
Total output power	-	-	100	Watts cont.
			122	Watts srge
*Manufacturing option				

Hard disc drive

The hard disc drive used on the workstations (except discless) is an internally-fitted SCSI device. For more information on the types of SCSI drive usable, see the *SCSI Expansion Card User Guide*.

Case colour specification

The colour of the cream plastic mouldings, the main case and the back panels which are painted, is Pearl White RAL 1013C.

The colour of the light grey front sub-moulding and the light grey keyboard keycaps is Pantone warm grey 3.

The colour of the darker grey keytops is Pantone warm grey 6.

DANGER
 THE POWER SUPPLY IS A SEPARATE REPLACEABLE MODULE, AND CONTAINS NO USER SERVICEABLE PARTS.
 ALL ACORN POWER SUPPLIES CONTAIN HAZARDOUS VOLTAGES AND MUST NOT BE MODIFIED OR REPAIRED.
 POWER SUPPLY UNITS MAY ONLY BE FITTED BY AN AUTHORISED ACORN SERVICE CENTRE.
 SAFETY EARTH CONTINUITY TESTING MUST BE CARRIED OUT WHEN ANY POWER SUPPLY IS FITTED.

Main PCB Links

Link	Fitted	Effect	Default
LK1	Yes	Internal auxiliary video connector providing access to the following signals: P1 Red P2 Green P3 Blue P4 H/CSync P5 VSync/Mode P6 0V	None
LK2	Yes	Provides option for video CSync to be superimposed on the Green video output signal: P1 Sync source P2 Green P3 0V Note that for a monitor that uses Sync on Green, move this link to the 1-2 position, and set the sync type to 1.	Shunt 2-3 (normal sync)
LK3	Yes	Used to configure the signal on pin 5 of the video socket: P1 VSync or $\overline{\text{VSync}}$ P2 Video socket pin 5 P3 Mode Note: Mode is a control signal used by some monitors with a SCART interface.	Shunt 2-3 (mode)
LK4	Yes	Test connector used in conjunction with Acorn designed test equipment: P1 5V P2 D<0> P3 La<21> P4 RomCS P5 Rst P6 0V	None
LK5	Yes	Provides simple oscillator signal.	None
LK6	Yes	Used to configure the signal on pin 4 of the video socket: P1 HSync/HSync P2 Video socket pin 4 P3 CSync	Shunt 2-3 (CSync)
LK7	No	Test point for non-volatile memory/RTC battery voltage: P1 0V P2 1.2V \pm 0.2V	None
LK8	No	Test point for RTC clock frequency: P1 0V P2 32.768 KHz	None
LK9	Yes	Internal auxiliary audio connector providing access to the following signals: P1 Unfiltered Left P2 0V P3 Left Phones P4 0V P5 Aux Input P6 0V P7 Right Phones P8 0V P9 Unfiltered Right P10 0V	None

Link	Fitted	Effect	Default
LK10	No	Internal test link, allowing phase adjustment of Hi-Res dot clock.	Trk 1-2
LK11	No	Internal test link, allowing phase adjustment of CK24M.	Trk 1-2
LK12	No	Allows the +5V supply to the floppy to be via the data cable or through a separate feed. For supply via data cable, cut track 22-3 and link positions 1-2.	Trk 2-3 (separate feed)
LK13	Yes	Connection point for the internal speaker: P1 0V P2 Signal	None
LK14	Yes	Connection point for POWER front panel LED.	None
LK15	Yes	Genlock connection point: P1 Internal clock P2 Clock to VIDC P3 Sink P4 0V P5 NC P6 NC P7 $\overline{\text{Ved0}}$ P8 $\overline{\text{VedT}}$ P9 $\overline{\text{Ved2}}$ P10 $\overline{\text{Ved3}}$ P11 Supremacy P12 Hi P13 HSync P14 Vs P15 0V P16 0V	Shunt 1-2 Shunt 3-4
LK23	Yes	Used in conjunction with LK24 and LK26 to select ROM SIZE: SIZE (Bits) LK24 LK23 LK26 512K 2-3 2-3 2-3 1M 2-3 2-3 2-3 2M 1-2 2-3 2-3 4M 1-2 1-2 2-3 8M 1-2 1-2 1-2	Shunts 2-3
LK24	Yes	See LK23.	
LK25	Yes	Used in conjunction with LK27 to select ROM TYPE: TYPE LK25 LK27 Non JEDEC 512K 1-2 1-2 Non JEDEC 1MB ROM 1-2 1-2 Non JEDEC 1MB EPROMs 1-2 1-2 JEDEC 1, 2, 4, and 8MB ROMs and EPROMs 1 -----1 2 -----2	Shunts 1-2
LK26	Yes	See LK23.	None
LK27	Yes	See LK25.	None
LK28	Yes	Not allocated	
LK29	Yes	Test point for MEMC reference clocks P1 5V P2 RefW (MEMCw) P3 RefX (MEMCx) P4 RefY (MEMCy) P5 RefZ (MEMCz) P6 0V NOTE: Links LK16 to LK22 inclusive are not fitted.	None

Plugs

Plug	Fitted	Function/Specification																																								
PL1	Yes	<p>Serial Port. (IBM PC-AT Pinout) 9-way D-type plug.</p> <table border="1"> <thead> <tr> <th>Pin</th> <th>Signal</th> <th>Pin</th> <th>Signal</th> </tr> </thead> <tbody> <tr> <td>1</td> <td>DCD</td> <td>6</td> <td>DSR</td> </tr> <tr> <td>2</td> <td>RxD</td> <td>7</td> <td>RTS</td> </tr> <tr> <td>3</td> <td>TxD</td> <td>8</td> <td>CTS</td> </tr> <tr> <td>4</td> <td>DTR</td> <td>9</td> <td>RI</td> </tr> <tr> <td>5</td> <td>0V</td> <td></td> <td></td> </tr> </tbody> </table>	Pin	Signal	Pin	Signal	1	DCD	6	DSR	2	RxD	7	RTS	3	TxD	8	CTS	4	DTR	9	RI	5	0V																		
Pin	Signal	Pin	Signal																																							
1	DCD	6	DSR																																							
2	RxD	7	RTS																																							
3	TxD	8	CTS																																							
4	DTR	9	RI																																							
5	0V																																									
PL2	Yes	<p>Floppy disc power connector.</p> <p>P1 +5V P2 0V P3 0V P4 +12V</p>																																								
PL3	Yes	<p>Processor module plug. This is a 96-way DIN 41612 plug. It provides all signals for CPU card.</p>																																								
PL4	Yes	<p>Floppy Disc Drive Data Connector. This is a 34-way Box Header containing all the signals required by the internal floppy disc drive.</p> <table border="1"> <thead> <tr> <th>Pin</th> <th>Signal</th> <th>Pin</th> <th>Signal</th> </tr> </thead> <tbody> <tr> <td>2</td> <td>Dcirq*</td> <td>20</td> <td>Step*</td> </tr> <tr> <td>4</td> <td>Inuse*</td> <td>22</td> <td>Writedata*</td> </tr> <tr> <td>6</td> <td>Sel(3)*</td> <td>24</td> <td>Writegate*</td> </tr> <tr> <td>8</td> <td>Index*</td> <td>26</td> <td>Track00*</td> </tr> <tr> <td>10</td> <td>Sel(0)*</td> <td>28</td> <td>Writeprot*</td> </tr> <tr> <td>12</td> <td>Sel(1)*</td> <td>30</td> <td>Readdata*</td> </tr> <tr> <td>14</td> <td>Sel(2)*</td> <td>32</td> <td>Side1*</td> </tr> <tr> <td>16</td> <td>Motoron*</td> <td>34</td> <td>Ready*</td> </tr> <tr> <td>18</td> <td>Dirin*</td> <td></td> <td></td> </tr> </tbody> </table> <p>* All signals are active low. 1,3,13,15,17,19,21,23,25,27,29,31,33 all 0V 5,7,9,11 optional power lines. See LK12.</p>	Pin	Signal	Pin	Signal	2	Dcirq*	20	Step*	4	Inuse*	22	Writedata*	6	Sel(3)*	24	Writegate*	8	Index*	26	Track00*	10	Sel(0)*	28	Writeprot*	12	Sel(1)*	30	Readdata*	14	Sel(2)*	32	Side1*	16	Motoron*	34	Ready*	18	Dirin*		
Pin	Signal	Pin	Signal																																							
2	Dcirq*	20	Step*																																							
4	Inuse*	22	Writedata*																																							
6	Sel(3)*	24	Writegate*																																							
8	Index*	26	Track00*																																							
10	Sel(0)*	28	Writeprot*																																							
12	Sel(1)*	30	Readdata*																																							
14	Sel(2)*	32	Side1*																																							
16	Motoron*	34	Ready*																																							
18	Dirin*																																									
PL5	Yes	<p>Power supply connector. This is a 6-way socket for connecting to the DC power supply.</p> <p>P1 +5V P2 0V P3 +12V P4 +5V P5 0V P6 -5V</p>																																								
PL6 to PL9		<p>Optional power supply connectors.</p> <p>PL6 -5V PL7 +12V PL8 0V PL9 +5V</p>																																								
PL10 PL11		<p>Chassis connection points.</p> <p>These two faston connectors provide a connection point between the keyboard cable screen and the case of the computer.</p>																																								

Sockets

Sket	Fitted	Function/Specification																																																
SK1	Yes	<p>Stereo headphone output.</p> <p>This is a 3-way 3.5mm stereo jack socket providing output to "Walkman-type" 32 ohm stereo headphones.</p>																																																
SK2	Yes	<p>RGB video socket.</p> <p>This is a 9-way D-type socket providing an interface to RGB monitors and Scart TVs. Links 2, 3 and 6 can be used to alter the synchronisation signals to suit a variety of monitors</p> <p>RGB video levels are 0.7V Pk-Pk into 75 Ohm. Sync voltage levels are >= 2.0V (TTL).</p> <table border="1"> <thead> <tr> <th>Pin</th> <th>Signal (IBM PC PGA pinning)</th> </tr> </thead> <tbody> <tr> <td>1</td> <td>Red</td> </tr> <tr> <td>2</td> <td>Green</td> </tr> <tr> <td>3</td> <td>Blue</td> </tr> <tr> <td>4</td> <td>HSync</td> </tr> <tr> <td>5</td> <td>VSync/Mode</td> </tr> <tr> <td>6,7,8,9</td> <td>0V</td> </tr> </tbody> </table>	Pin	Signal (IBM PC PGA pinning)	1	Red	2	Green	3	Blue	4	HSync	5	VSync/Mode	6,7,8,9	0V																																		
Pin	Signal (IBM PC PGA pinning)																																																	
1	Red																																																	
2	Green																																																	
3	Blue																																																	
4	HSync																																																	
5	VSync/Mode																																																	
6,7,8,9	0V																																																	
SK3	Yes	<p>Parallel printer port.</p> <p>25-way D-type socket providing a parallel printer interface.</p> <table border="1"> <thead> <tr> <th>Pin</th> <th>Signal</th> <th>Pin</th> <th>Signal</th> <th>Pin</th> <th>Signal</th> </tr> </thead> <tbody> <tr> <td>1</td> <td>StB</td> <td>8</td> <td>Pd(6)</td> <td>15</td> <td>nc</td> </tr> <tr> <td>2</td> <td>Pd(0)</td> <td>9</td> <td>Pd(7)</td> <td>16</td> <td>nc</td> </tr> <tr> <td>3</td> <td>Pd(1)</td> <td>10</td> <td>ACK</td> <td>17-25</td> <td>0V</td> </tr> <tr> <td>4</td> <td>Pd(2)</td> <td>11</td> <td>Bsy</td> <td></td> <td></td> </tr> <tr> <td>5</td> <td>Pd(3)</td> <td>12</td> <td>nc</td> <td></td> <td></td> </tr> <tr> <td>6</td> <td>Pd(4)</td> <td>13</td> <td>nc</td> <td></td> <td></td> </tr> <tr> <td>7</td> <td>Pd(5)</td> <td>14</td> <td>nc</td> <td></td> <td></td> </tr> </tbody> </table>	Pin	Signal	Pin	Signal	Pin	Signal	1	StB	8	Pd(6)	15	nc	2	Pd(0)	9	Pd(7)	16	nc	3	Pd(1)	10	ACK	17-25	0V	4	Pd(2)	11	Bsy			5	Pd(3)	12	nc			6	Pd(4)	13	nc			7	Pd(5)	14	nc		
Pin	Signal	Pin	Signal	Pin	Signal																																													
1	StB	8	Pd(6)	15	nc																																													
2	Pd(0)	9	Pd(7)	16	nc																																													
3	Pd(1)	10	ACK	17-25	0V																																													
4	Pd(2)	11	Bsy																																															
5	Pd(3)	12	nc																																															
6	Pd(4)	13	nc																																															
7	Pd(5)	14	nc																																															
SK4	Yes	<p>Econet socket.</p> <p>5-way DIN socket for connection to Econet LAN. Note, this is an upgrade.</p> <table border="1"> <thead> <tr> <th>Pin</th> <th>Signal</th> </tr> </thead> <tbody> <tr> <td>1</td> <td>Data</td> </tr> <tr> <td>2</td> <td>0V</td> </tr> <tr> <td>3</td> <td>Clock</td> </tr> <tr> <td>4</td> <td>Data</td> </tr> <tr> <td>5</td> <td>Clock</td> </tr> </tbody> </table>	Pin	Signal	1	Data	2	0V	3	Clock	4	Data	5	Clock																																				
Pin	Signal																																																	
1	Data																																																	
2	0V																																																	
3	Clock																																																	
4	Data																																																	
5	Clock																																																	
SK5, SK6, SK7	Yes	<p>Memory expansion sockets.</p> <p>Allow memory expansion of 4MB at a time, up to a maximum of 16MB. Note, the DPAM cards must be inserted in the correct order: SK5, SK6, SK7.</p>																																																
SK8	Yes	<p>Econet upgrade module socket.</p> <p>5-way header used in conjunction with SK10. This module is identical to that used on Acorn Master series and Archimedes computers.</p>																																																
SK9	Yes	<p>Backplane socket.</p> <p>Systems are normally supplied with a 4-way backplane already installed.</p>																																																
SK10	Yes	<p>Econet upgrade module socket.</p> <p>17-way header used in conjunction with SK8 to provide the electrical connection point for the internal Econet upgrade module. This module is identical to that used on Acorn Master series and Archimedes computers.</p>																																																

Sockets (cont.)

Skt	Fitted	Function/Specification
SK11	Yes	6-way mini-DIN socket providing the connection point for the keyboard. If required, a standard Archimedes keyboard may be plugged into this socket.
SK12	Yes	High resolution mono video output. Provides a 0.7V mono video signal (into 75 Ohm) at a dot rate of 96MHz. This requires a High resolution monitor to be connected.
SK13	Yes	High resolution mono vertical sync. Provides composite/vertical synchronisation pulses for the high resolution mono output.
SK14	Yes	High resolution mono horizontal sync. Provides horizontal synchronisation pulses for the high resolution mono output.

Internal expansion

Interface

Introduction

The computer supports an expansion card (podule) interface. The maximum power available per slot can be calculated from the following:

- The +5V supply rail is rated at a maximum of 1A
- The +12V supply rail is rated at a maximum of 250mA
- The -5V supply rail is rated at a maximum of 50mA

Refer to the application note 'A Series Podules' for a full podule interface specification, available on request from Acorn Computers.

Pin	a	c	Description
1	0V	0V	Ground
2	LA[15]	-5V	
3	LA[14]	0V	Ground
4	LA[13]	0V	Ground
5	LA[12]	reserved	
6	LA[11]	MS[0]*	MEMC Podule select
7	LA[10]	reserved	
8	LA[9]	reserved	
9	LA[8]	reserved	
10	LA[7]	reserved	
11	LA[6]	reserved	
12	LA[5]	RST*	Reset (see note below)
13	LA[4]	PR/W*	Read/not write
14	LA[3]	PWE*	Write strobe
15	LA[2]	PRE*	Read strobe
16	BD[15]	PIRQ*	Normal interrupt
17	BD[14]	PFIQ*	Fast interrupt
18	BD[13]	S[6]*	
19	BD[12]	C1	I ² C serial bus clock
20	BD[11]	C0	I ² C serial bus data
21	BD[10]	S[7]*	External Podule select
22	BD[9]	PS[0]*	Simple Podule select
23	BD[8]	IOGT*	MEMC Podule handshake
24	BD[7]	IORQ*	MEMC Podule request
25	BD[6]	BL*	I/O data latch control
26	BD[5]	0V	Supply
27	BD[4]	CLK2	2MHz Synchronous clock
28	BD[3]	CLK8	8MHz Synchronous clock
29	BD[2]	REF8M	8MHz Reference clock
30	BD[1]	+5V	Supply
31	BD[0]	reserved	
32	+5V	+12V	

Note: The RST* signal is the system reset signal, driven by IOC on power up or by the keyboard reset switch. It is an open-collector signal, and expansion cards *may* drive it also if this is desirable. The pulse width should be at least 50ms.

Part 2 - Interface cards

Ethernet interface

Where an Ethernet interface is fitted, it is provided by one of two different types of Ethernet expansion card, identified as Ethernet I and Ethernet II. Both cards can support either a 'thick' or 'thin' (*Cheapernet*) Ethernet interface.

Overview

Ethernet was developed by the Xerox Corporation in the early 1970s and a specification made available in 1980. This specification known as the 'Blue Book' was used as the basis for the IEEE and ECMA standards. All new equipment (including this product) is or should be designed to the IEEE standard. This allows networking with existing Ethernet equipment, at least at the physical level.

An understanding of the basic architecture of the Ethernet/IEEE 802.3 standard is assumed. The Intel publication *The LAN Components User's Manual* is particularly useful and contains a suitable introduction to local area network standards. It is recommended that you obtain a copy if you require a wider understanding, as reference to it is made in this document.

Ethernet I expansion card

Basic operation and block diagram

Figure 2-1: Ethernet I expansion card block diagram is a block diagram of the Ethernet/Cheapernet module.

The main functional blocks are:

- the net controller: Intel 82586 (LANCE)
- the serial interface adaptor: Intel 82501 (SIA)
- transceiver: Intel 82502
- attachment unit interface (AUI) socket (D-type)
- isolation transformers and power supply
- bus buffers and transceivers
- the RAM buffer
- the RAM page register
- a PROM based 'extended' module ID
- the control register
- the PAL based state machine.

Figure 2-1: Ethernet I expansion card block diagram

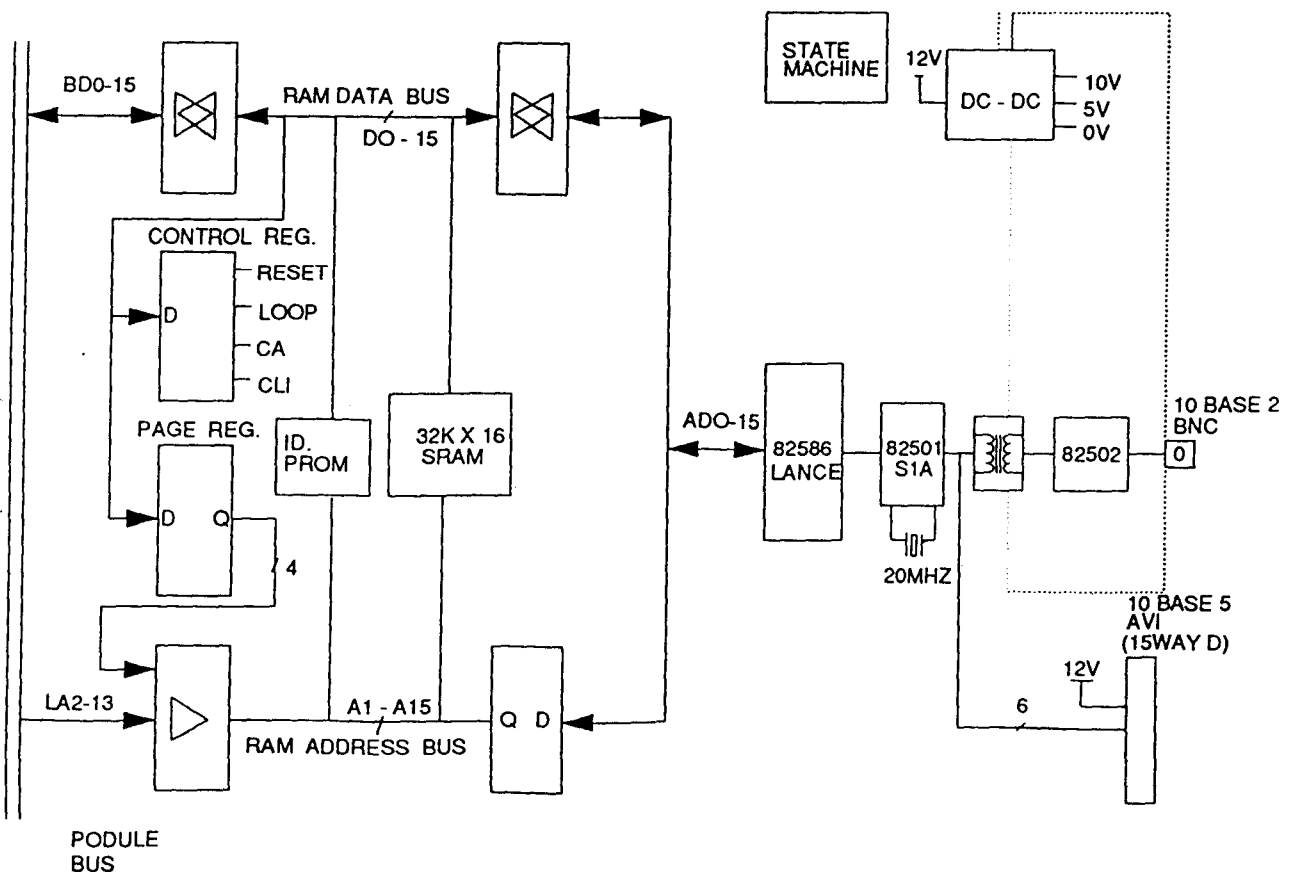

The Intel chip set

As the Xerox and IEEE standards have become widely accepted, a number of systems companies have produced VLSI devices that considerably reduce the design effort required to implement a connection. The most notable of these are by Advanced Micro Devices (AMD) and Intel.

The Intel chip set comprising the 82586 local area network coprocessor, the 82501 Ethernet serial interface, and the 82502 Ethernet transceiver chip has been used in this design.

The 82586 and other similar local area network controllers are generally referred to by the acronym LANCE, even though this is a trademark of AMD.

The 82586 LANCE performs media access control, framing, pre/postamble generation and stripping, source address generation, CRC checking, and short packet detection. In addition diagnostic functions such as Time Domain Reflectometry (TDR) can be performed.

The 82501 serial interface adapter (SIA) performs Manchester encoding/decoding, receives clock recovery and directly drives the attachment unit interface (AUI) to the cable mounted Ethernet transceiver. In addition the 82501 operates a watchdog to prevent continuous transmission (a fault condition), and provides a loop-back test facility. A second source for this device is SEEQ who manufacture a similar part, the DQ8023A. This part however is not identical and will not perform TDR correctly.

The 82502 transceiver applies transmit data to, and removes receive data from the Cheapernet cable interface. This device performs a similar function to the cable mounted Ethernet transceiver.

The dual port memory

The LANCE is a true coprocessor and is designed to perform scatter-gather DMA. In common with other LANCE chips the 82586 will utilise a significant bus bandwidth when operating on a net running at 10 Mbps (note: this is not simply the serial data rate divided by the parallel bus width). This bandwidth cannot be provided by the ARM processor over the podule bus and so a dual-port memory system has been implemented.

All communication between the ARM and the LANCE is carried out through command blocks in the dual-port RAM (there are no visible registers in the 82586 LANCE). These command blocks and associated data structures are defined and described in Intel's data sheet.

To issue a command to the LANCE the ARM appends the command to the command block list (CBL) in the dual-port RAM. It then raises the channel attention (CA) signal to the LANCE signalling the presence of the new command. The LANCE responds to CA by reading the command from the CBL and executing as required.

The *LAN Components User's Manual* contains a considerably more detailed and comprehensive description of the operation of the LANCE.

The control register

The control register contains four bits:

Reset (RST) Bit 0.

This bit controls the RESET pin on the LANCE. This bit is set (LANCE reset) on system power-up/hard reset or writing to the control register with this bit logic 1. This bit is cleared (and the LANCE released from the reset state) by writing to the control register with this bit logic 0.

Loop-Back (LB) Bit 1

This bit selects the loop-back mode of 82501 SAI chip. This bit is set and the SIA chip put into loop-back mode by the ARM writing to the control register with this bit logic 1. This bit is cleared (SIA taken out of loop-back mode) on system power-up/hard reset or writing to the control register with this bit logic 0.

Channel Attention (CA) Bit 2

This bit generates a correctly timed CA pulse when the ARM writes to the control register with this bit logic 1. No CA pulse is generated if the ARM writes to the control register with this bit logic 0.

Clear Interrupt (CLI) Bit 3

This bit clears the podule interrupt flag and removes the podule interrupt when the ARM writes to the control register with this bit logic 1. The podule interrupt and flag are unaffected if the ARM writes to the control register with this bit logic 0.

Each bit in the control register is not independent and when writing to a particular bit, the remaining three must be valid. The remaining 12 bits are ignored by the hardware (zero is recommended).

Podule Identification PROM

The podule identification PROM contains the following information:

- the Acorn podule identity number (03)
- the interrupt (IRQ) flag bit
- the PCB revision number
- the six byte IEEE globally assigned address block
- a CRC to allow the PROM to be validated.

The contents and operation of the interrupt flag are described in *Interrupts in Detailed description* below.

Detailed description

Address map

The Ethernet I expansion card address map (offset relative to slot base) is shown in *Table 2-1: Ethernet I expansion card address map*. The RAM buffer occupies the upper half of the podule address space. The ID PROM, page register and control register occupy the lower half.

The LANCE

The 82586 LANCE is a 'scatter-gather' DMA controller type device and is designed to interface to 80186 type processors using a HOLD/HOLDA protocol to resolve arbitration for access to shared memory.

The ARM podule bus cannot easily support a HOLD/HOLDA type interface. This is because the ARM is a dynamic device and cannot be stopped for the required time. (This can be longer than 10 μs during the interframe/interpacket spacing time.) The ARM cannot be given priority and HOLDA deasserted because this will result in the net controller failing to meet the timing requirements of the net protocol due to the increased bus latency. For example, this could result in the failure of the net controller to take part in the back-off and retry sequence following a collision on a heavily loaded net. In this design HOLD and HOLDA are wired together and ARM cycles cause wait-states to be inserted into the LANCE bus cycle. This is achieved by removing the READY signal to the LANCE while the ARM is active.

Adopting this scheme avoids the problems outlined above. The ARM is never stopped and the LANCE sees minimal bus latency.

The LANCE ARDY/SRDY input used can be programmed to be either asynchronous/ ARDY and internally synchronised, or synchronous/SRDY and externally synchronised. In this case it is SRDY mode that must be selected. This is achieved by issuing a configure command with the ARDY/SRDY bit set to logic 1. This is important as the LANCE powers-up in ARDY mode.

In certain circumstances the LANCE needs to perform read-modify-write bus cycles with lockout. Using READY to insert wait-states does not allow this. However lockout is only required when the LANCE updates error counts (statistics) and even then a problem only arises when a count overflows and the ARM resets it to zero while the LANCE is in the modify phase of a read-modify-write cycle. This is solved by the ARM reading back the count after it sets it to zero. If the count is still indicting an overflow then a read modify-write cycle was in progress

Table 2-1: Ethernet I expansion card address map

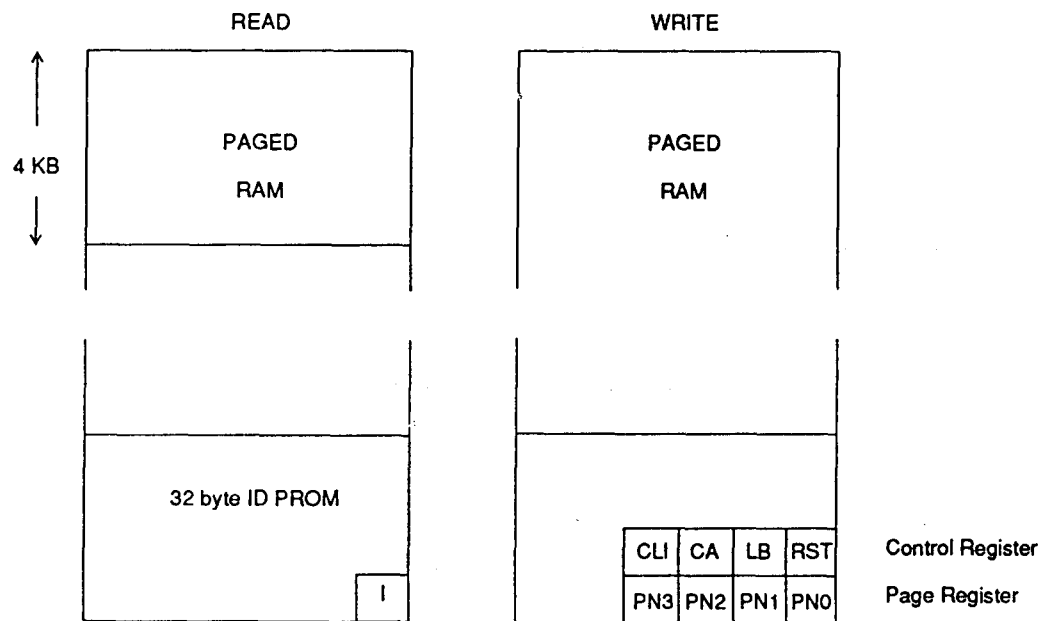

ID PROM (Base)	= Slot base	(Type 3 access) + 0x0000 (Read only)
Page Register	= Slot base	(Type 2 access) + 0x0000 (Write only)
Control Register	= Slot base	(Type 2 access) + 0x0004 (Write only)
Dual-Port RAM	= Slot base	(Type 2 access) + 0x2000 (Read/write)

and the ARM has to correct the count. Error counts this high indicate a major problem that will require correction so should be a rare event.

The memory bus of the LANCE is operated in 'minimum mode' as the timing parameters for LANCE outputs in this mode are subject to less spread between devices. The pull-up resistors on WR*, RD*, and BHE are required to prevent RAM cycles when the LANCE is inactive.

The LANCE communicates directly with the SIA (IC24) via a serial channel comprising seven signals: TXC, TXD, RXC, RXD, RTS, CRS and CDT. The function of each of these is described in the LANCE data sheet. The Clear-to-Send (CTS*) input is not supported by the SIA and is connected to 0V (enabled).

Dual port RAM

The podule bus provides only a limited space in the address map (8 KB) for each podule. This is insufficient and so a paged scheme has been implemented.

Viewed from the ARM side the RAMs are paged into the top half of podule space by a 'page register'. The four bit page register is split across two PALs (see the section entitled *The PALs*). Sixteen pages each of 4 KB provide 64 KB in total. This is organised as 32 k x 16 bits (two 32 k x 8 static RAMs). An alternative RAM size of 8 k x 16 bits (two 8 k x 8 static RAMs) can be supported (see the section entitled *Links* on page 2-12).

The podule address bus (LA2-13) is buffered by two HCT244 (IC66 and IC58) and the podule data bus (BD0-BD15) is buffered by and two HCT245 transceivers (IC15 and IC54). The direction of the data bus transceivers is determined by the podule R/W signal, while both output enables (AAOE and BDOE) are generated by the bus control PAL (IC36).

Viewed from the net controller side, the RAM will be contiguous from location 0x0000 to 0xFFFF. The initialisation root for the controller is 0xFFFFF6 which is mapped into the RAM at 0xFFF6. The high order address bits are not decoded.

The LANCE address/data bus (AD0-AD15) is demultiplexed by two HCT245 (IC17 and IC22) which use the LANCE ALE signal to latch the address bus. The data bus only requires buffers and two HCT573 transceivers (IC10 and IC32) are used. The direction of the data bus transceivers is determined by the LANCE DT/R signal, while the output enables are generated by the bus control PAL (IC36).

The LANCE is capable of operating on an eight bit bus and is reset to this mode. The LANCE initialisation root (read when released from reset) contains a bit that defines the bus width and this must be set to 0 (=16 bit bus). Until the LANCE reads this it deasserts Byte High Enable (BHE*) and outputs address bits on AD8-AD15 for the entire cycle. To avoid a bus clash BHE* is used to disable the high order data bus transceiver via the bus control PAL (IC36).

Once initialised to a byte wide bus the LANCE only operates on half words (never bytes) so it not necessary to decode the least significant address bit (AD0) to produce separate write strobes for each byte.

Podule Identification PROM

The device used is a 32 byte PROM 27LS19 (IC14). Typical content of an ID PROM is shown in Table 2 overleaf.

The ID PROM shares address and data bus buffers with the RAM. Viewed from the ARM side the ID PROM is byte wide and word aligned.

The podule specification defines two bits in the ID byte to be interrupt flags. This design requires only IRQ interrupts so the FIQ flag is always zero. The IRQ flag is generated by connecting the podule interrupt signal to the most significant address pin. The content of the upper half is similar to the lower half but has the IRQ flag bit set, in this way the interrupt flag is multiplexed 'into' the ID byte.

Bytes 09 - 0E are the six byte Ethernet address unique across all Ethernet equipment from manufacturers worldwide.

The CRC (Bytes 1C - 1F) is calculated on the rest of the PROM (Bytes 00 - 1B) using a 32 bit Autodin - II CRC polynomial. This is the same algorithm as the LANCE uses to perform multicast address filtering (see the section entitled *PROM CRC calculation* on page 2-12). Since each PROM is unique the CRC is used to perform verification.

The output enable is generated by the bus control PAL (IC36).

The PALs

Three PALs are used in this design:

- the main state PAL (IC29)
- the interrupt and channel attention PAL (IC78)
- the device enable control PAL (IC36).

The main state PAL (IC29)

This PAL implements a state machine which provides timing information for the other two PALS in the design. In addition it produces the two least significant bits of both the page register (PR0 and PR1) and control register (RSTO and LOOP).

The interrupt and channel attention PAL (IC78)

This PAL implements the two most significant bits of both the page register (PR2 and PR3) and control register (CLI and CA).

The device enable control PAL (IC36).

This device decodes the address map to provide various device output enables.

Table 2-2: Podule Identity PROM

	D7	D6	D5	D4	D3	D2	D1	D0	NOTES
1F	C	C	C	C	C	C	C	C	CRC on bytes 00 - 1B
1E	C	C	C	C	C	C	C	C	
1D	C	C	C	C	C	C	C	C	
1C	C	C	C	C	C	C	C	C	
1B									Bytes 11 to 1B = 00
11									
10	0	0	0	0	0	0	0	1	01 - no FIQs, IRQ = 1
0F	0	0	0	0	0	0	0	0	00 - RSVD
0E									Unique ID
0D									
0C									
0B	1	0	1	0	0	1	0	0	A4
0A	0	0	0	0	0	0	0	0	00
09	0	0	0	0	0	0	0	0	00
08	0	0	0	0	0	0	0	1	01 - PCB rev. eg one
07	0	0	0	0	0	0	0	0	00 - UK
06	0	0	0	0	0	0	0	0	Acorn
05	0	0	0	0	0	0	0	0	
04	0	0	0	0	0	0	0	0	Ethernet
03	0	0	0	0	0	0	1	1	
02	0	0	0	0	0	0	0	0	00 - RSVD
01	0	0	0	0	0	0	0	0	00 - no boot code
00	0	0	0	0	0	0	0	0	00 - no FIQs, IRQ = 0

The state machine and operation

The state machine has four states; IDLE, SA1, SA2, and SA3 and is clocked from state to state on the falling edge of CLK8, the 8 MHz podule bus clock. See *Figure 2-2: State diagram*.

The idle state

The state machine enters this state on power-up, hard reset (RST* low), or from the SA3 state. In this state the bus buffers on the ARM side of the dual-ported RAM are disabled and those on the LANCE side enabled. Other outputs such as the page and control register bits remain unchanged. The state machine remains in the idle state until the ARM starts an access (podule select - PS active).

The SA1 state

This state is entered from the idle state only. In this state the LANCE READY signal is disabled, forcing the LANCE to insert wait states if it is active on the bus. The RAM write strobe (RAMWE*) is disabled to prevent writes while the LANCE side of the dual-port RAM is disabled and the ARM side enabled. The state machine exits to the SA2 state unless a reset occurs.

The SA2 state

This state is entered from the SA1 state only. In this state the ARM access is performed and the corresponding device enables are active eg, if a RAM write is performed then the RAM write strobe (RAMWE*) is active. Similarly if a RAM or ID read is required then the RAM or IDOE is active. Writes to the page register or control bits are also

performed during this state. state machine exits to the S occurs.

The SA3 state

This state is entered from the write strobe (RAMWE*) is disabled the LANCE side of the dual-ARM side disabled. The state where any LANCE access completed.

Podule bus cycles

The podule specification req be made using type 3 (sync accesses to the Ethernet po type 2 (fast) IOC cycles.

Figure 2-3: Typical podule b read/write to RAM while the cycle starts with podule sel state machine into the SA1 s
 A description of each state t
 It should be noted that *Reac* three cycles, even if the LAN access can 'collide' with a L/ ways, depending on what sta podule bus access starts. Th is in states T1 to T4 or idle. states that the LANCE will ir these cases apply. Figures 2 the possible cases.

Figure 2-2: State diagram

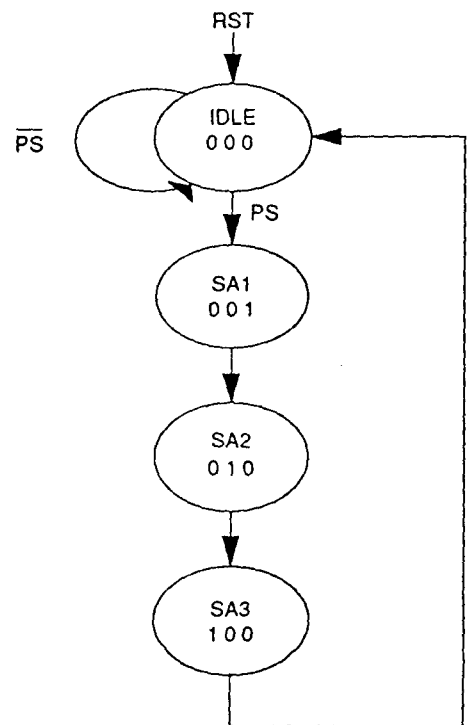

Figure 2-3: Typical podule bus cycle

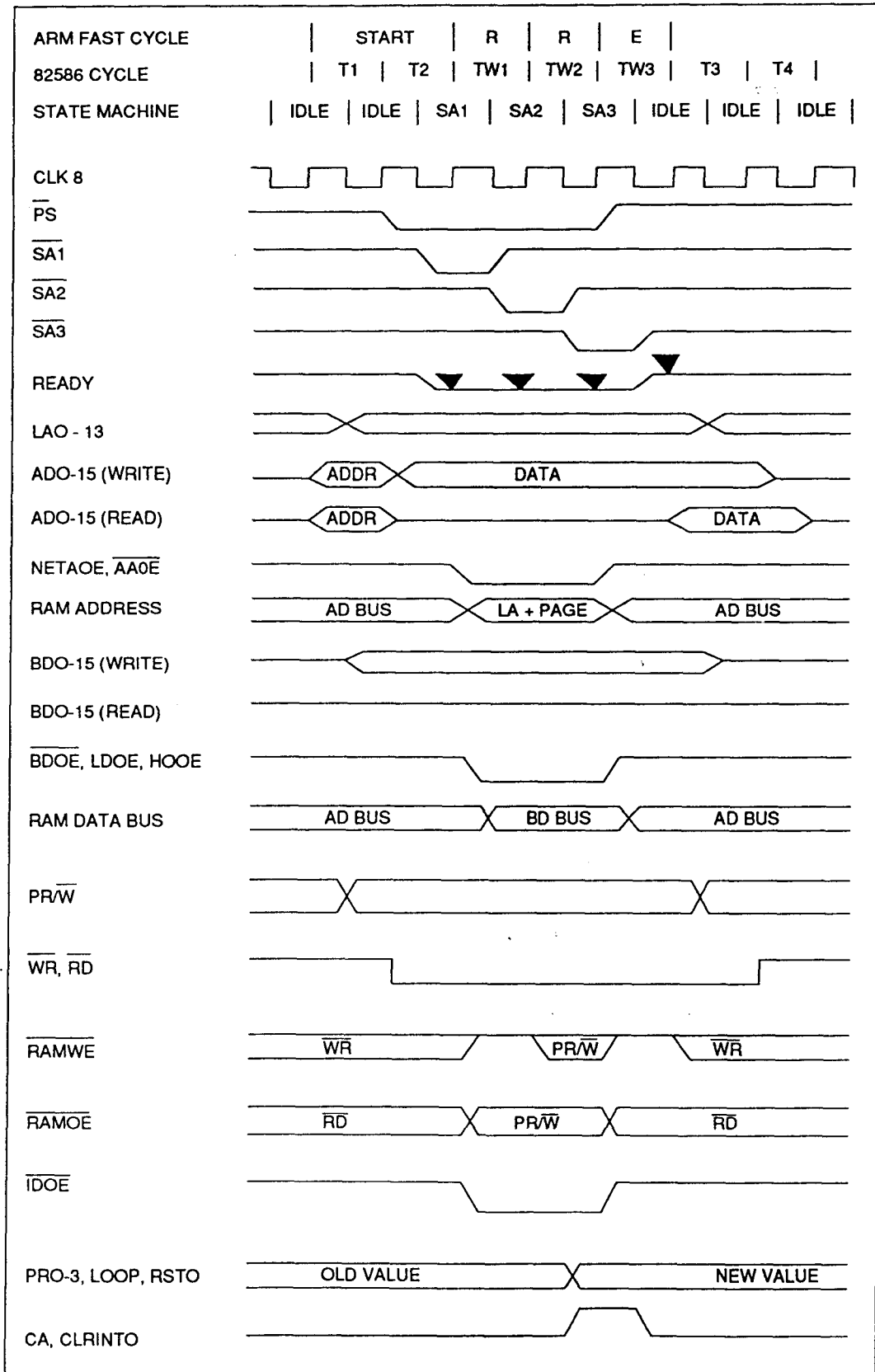
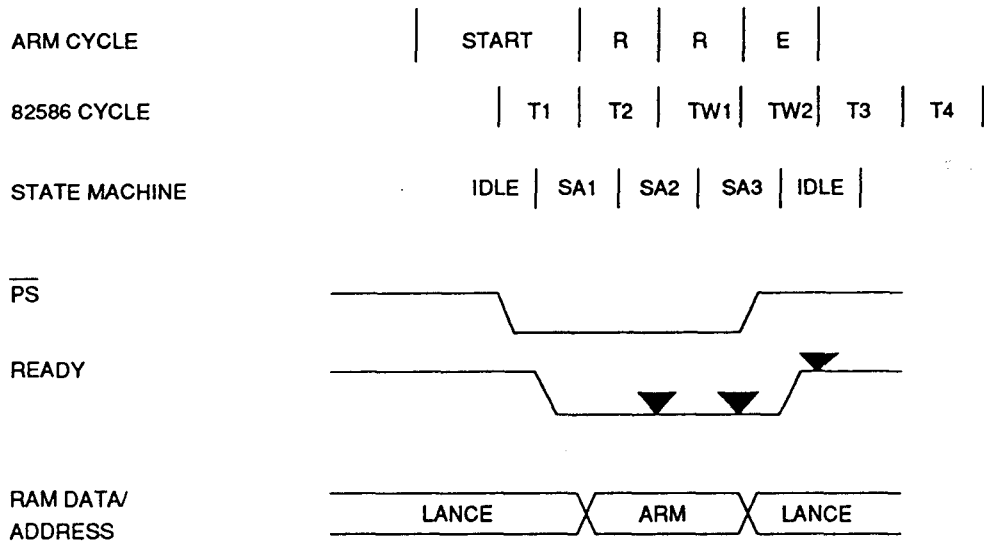

Figure 2-4: Access collision cases PS* while LANCE is in T1



PS* while the LANCE is in T1

The LANCE samples READY deasserted at the end of T2 (SA2), and then again at the end of TW1 (SA3), so in this case two wait states are inserted.

Figure 2-5: Access collision cases PS* while LANCE is in T2

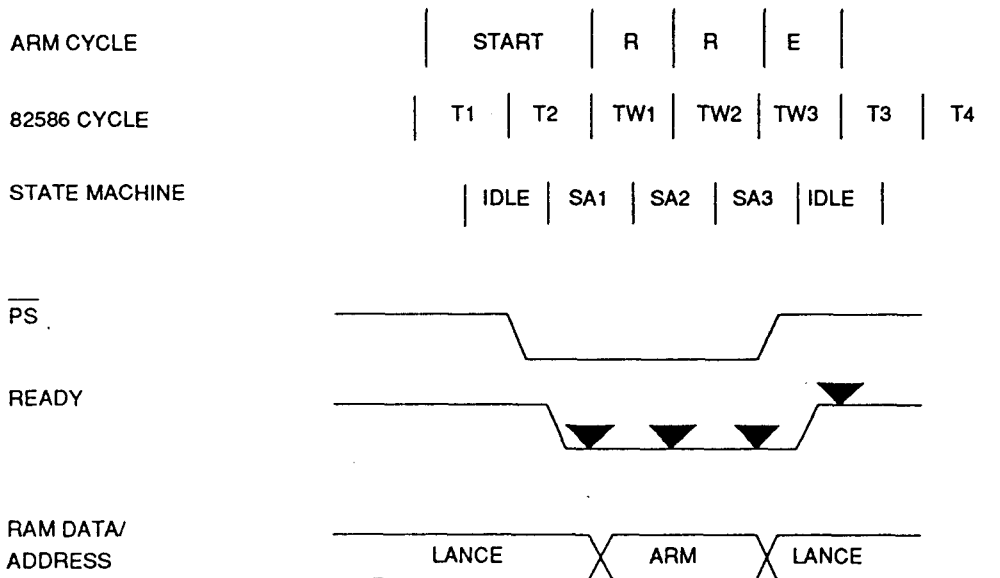

PS* while the LANCE is in T.2

The LANCE samples READY deasserted at the end of T2 (SA1), TW1 (SA2), TW2 (SA3), so the maximum of three wait states are inserted.

Figure 2-6: Access collision cases PS* while LANCE is in T3

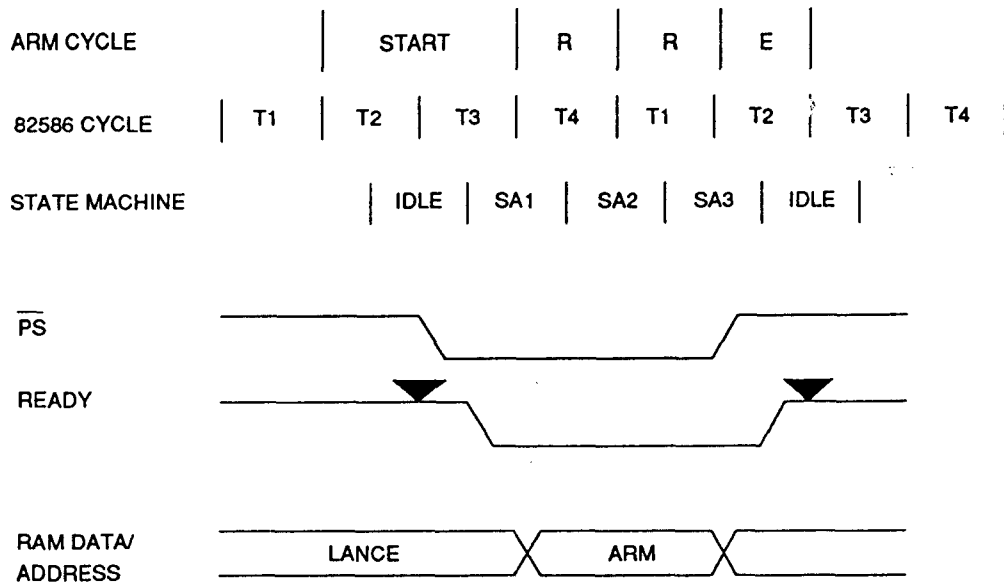

PS* while the LANCE is in T3

In this case READY is still active when the LANCE samples it at the end of T3 (idle). This is the last time that the LANCE does this for the current cycle so the LANCE cycle completes before the podule bus cycle starts. Note that the LANCE is not active on the RAM bus during T4.

Figure 2-7: Access collision cases PS* while LANCE is in T4

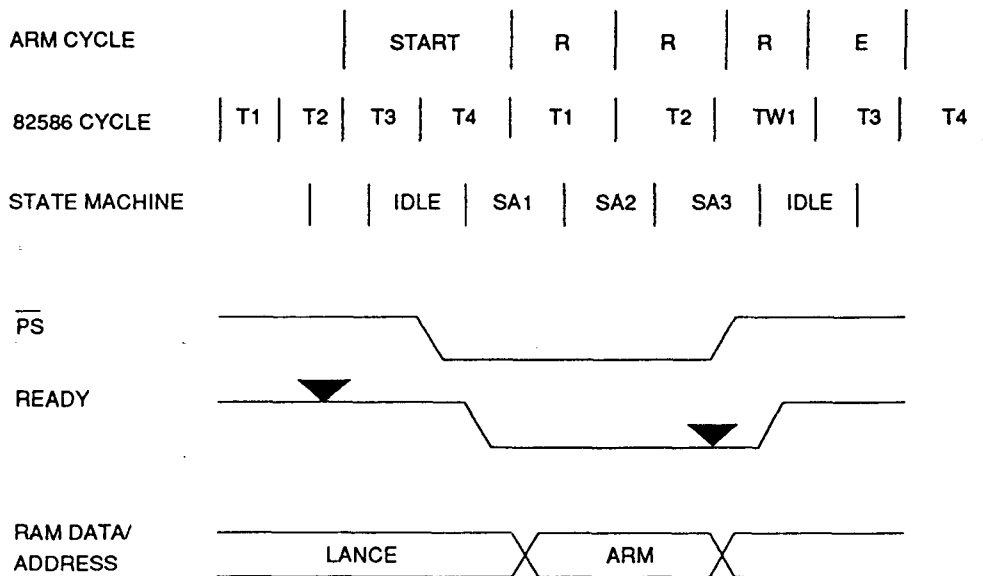

PS* while the LANCE is in T4

Since the LANCE does not require the bus during T4 no further wait states are inserted in the current cycle. However T1 of the next cycle could follow T4 and one wait state will be inserted into this LANCE access.

PS* while the LANCE is idle

If the LANCE remains idle while the podule bus cycle occurs then there is no collision and the LANCE ignores the READY signal. This case is not illustrated.

A read from the podule ID PROM or write to the control or page register is similar to a RAM cycle. To simplify the bus design the LANCE is removed from the RAM buses during cycles to these devices.

Bus design note

The cycle stealing scheme should guarantee that the LANCE never has insufficient bus bandwidth or sees excessive bus latency to the extent that it cannot service the net or fails to meet the IEEE timings. Even when the ARM continuously accesses the RAM. The following gives the reasoning behind this statement:

Assumptions:

- Net Clock = 10 MHz
- Bus Clock = 8 MHz
- LANCE FIFO size = 16 bytes
- HOLDA is wired to HOLD so:
- Bus Latency = 0 cycles
- IEEE Interframe Space Time = 9.6 μS

Criteria:

- 1 FIFO must not over/underrun.

FIFO fill/empty time from serial side:

$$= 8 \text{ (bits)} * 16 \text{ (bytes)} * 100\text{E-}9 \text{ (bit time)}$$

$$= 12.8 \mu\text{s}$$

FIFO empty/fill time from parallel side:

$$= 8 \text{ (Word transfers)}$$

$$* (4 \text{ (standard 8 MHz cycles)} + N_{\text{wait}} \text{ (wait cycles)})$$

$$* 125\text{E-}9$$

$$= 4 \mu\text{s (if } N_{\text{wait}} = 0)$$

$$= 7 \mu\text{s (if } N_{\text{wait}} = 3)$$

$$= 8 \mu\text{s (if } N_{\text{wait}} = 4)$$

- 2 The LANCE must be in a position to transmit by the end of the interframe spacing time.

With a Fp/Fs ratio of 8 MHz/10 MHz (0.8):

$$16 * N_{\text{wait}} + N_{\text{latency}} \text{ must be less than or equal to } 80.$$

$$\text{If } HOLDA = HOLD \text{ then } N_{\text{latency}} = 0$$

and

$$N_{\text{wait}} \leq 5$$

So this strategy works if we can keep the number of wait states (Nwait) less than or equal to five per access. In the current design three are used and this is unlikely to change.

Interrupts

The podule interrupt (PIRQ) is level triggered. However, the interrupt signal (INT) from the LANCE is designed for use with edge triggered interrupt controllers. If the net controller detects a second interrupting condition just after the first is raised, it will drop and reassert INT. The situation could arise where the podule manager (software) may scan the slots and find no IRQ flag set.

The above problem is prevented by latching INT in the interrupt and channel attention PAL (IC78) and using the latched signal INTO to generate the flag. The clear interrupt (CLI) bit in the control register is used to clear the latch.

Latching INT introduces another problem, which is eliminated by a feature of the 82586 LANCE. If a second interrupt occurs after the processor has read the status word in the SCB, but before the first is cleared, then the second interrupt would be missed. However, if the interrupt is cleared at the same time as the channel attention (signalling the acknowledge command) is issued, the LANCE will respond by deasserting INT and reasserting if the second interrupt was not acknowledged because it was missed. It is recommended to set CA whenever CLI is set.

Figure 2-8: Example interrupt cycles

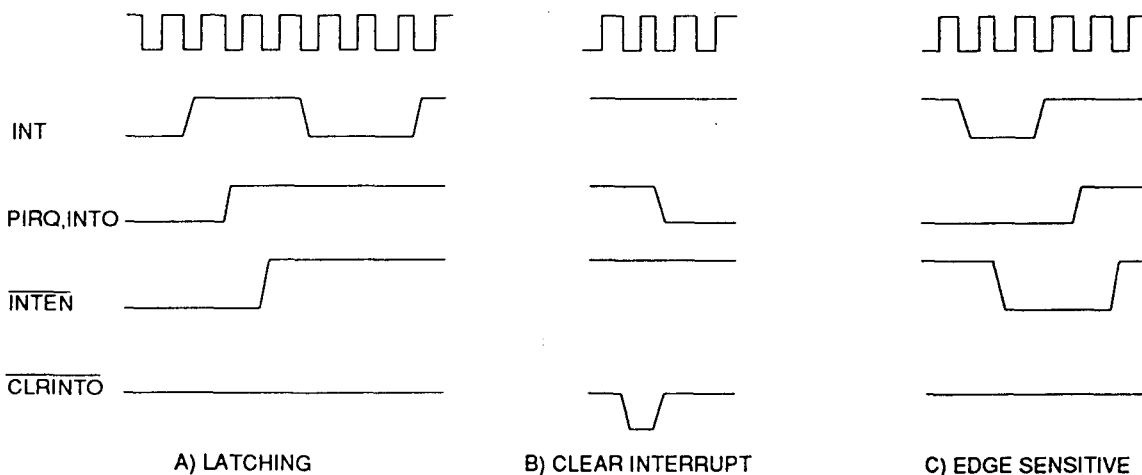

Figure 2-9: State diagram for INTO/PIRQ*

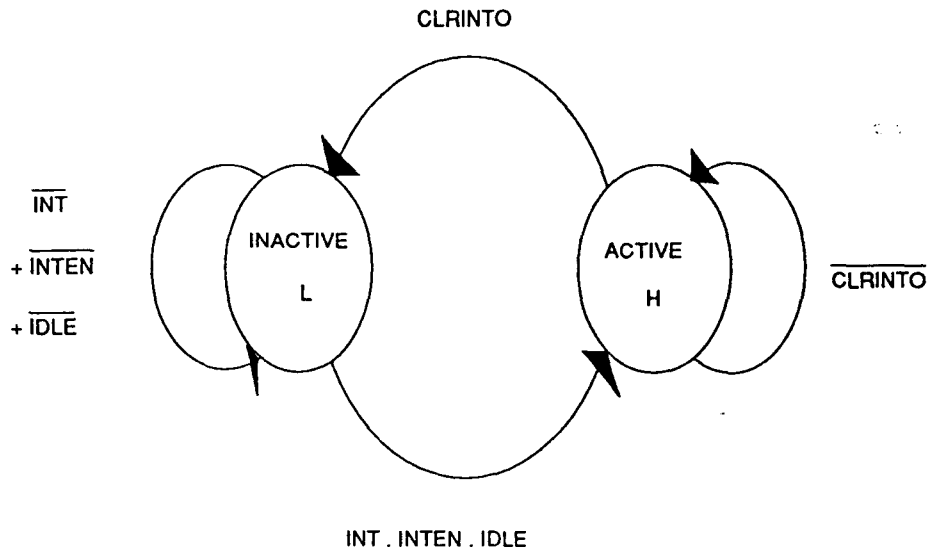
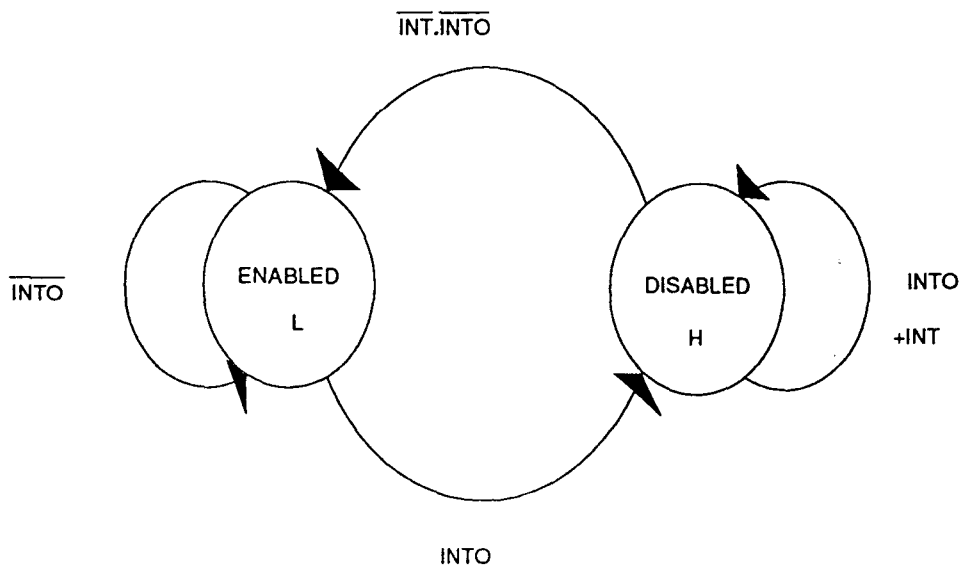

Figure 2-10: State diagram for INTEN*



Links

The Ethernet I PCB should be viewed from the component side with the 96 way podule bus connector on the left and the rear panel on the right. When viewed like this, west is to the left, east the right, north the top and south the bottom.

LK1 and LK2 select the RAM size

If 32 KB devices are fitted (normally) the links should both be south. 8 KB devices will not normally be fitted but in this case LK1 and LK2 should be north.

LK3 to LK8 select Ethernet or Cheapernet.

For Ethernet operation the links should be west (link pin a to pin b). For Cheapernet operation the links should be east (link pin b to pin c).

LK9 is tracked south and not fitted on production units.

See data sheets for the 82502 for use.

PROM CRC calculation

The following is a code fragment in the C programming language that calculates and validates the Ethernet PROM checksum.

```

/* To calculate and check the PROM checksum */
int ROM_chk(vector)                                /* array 0..32 bytes*/
u_char vector[32];
{ register int i,j;
  register unsigned chk = -1;                      /* Set the CRC register*/
                                                    /* to FFFFFFFF*/
                                                    /* temp
                                                    /* CRC on bytes 0..28*/

  register unsigned byte;
  for (i = 0; i < 28; i++) {
    byte = vector[i];
    for (j = 0; j < 8; j++) {
      if (((byte & 1) ^ (chk >> 31)) != 0)          /* IF feedback = 1*/
        chk = (chk << 1) ^ (0x04C11DB7);          /* shift and EOR taps*/
      else
        chk = (chk << 1);                          /* ELSE
                                                    /* just shift*/
      byte = byte >> 1;                             /* next bit*/
    }
  }

  /* chk is now the calculated CRC */
  /* Now get CRC from PROM */
  byte = (vector[31] << 24) | (vector[30] << 16) | (vector[29] << 8) |
    (vector[28] << 0);
  /* Test to see if the same */
  if (byte != chk) return (FALSE); /* checksum error*/
  else return (TRUE);
}

```

Ethernet II expansion card

The IEEE 803.2 standard supports two different versions for the media:

- 10BASE5 (commonly known as Ethernet)
- 10BASE2 (thin-wire Ethernet, or 'Cheapernet').

These can be used separately, or together in a hybrid form. Both versions have similar electrical specifications and can be implemented using the same transceiver chip. Thin-wire Ethernet is the lower cost version and is user-installable. Main differences are in the segment length, network span and nodes per segment, with thin-wire Ethernet having only one-third of the performance. The capacitance per node and the cable cost are however much less.

The Ethernet expansion card has been designed to provide the physical and media access control layer functions of the local area network as specified in IEEE 802.3 standard. This standard is based on the access method known as Carrier-Sense Multiple Access with Collision Detection (CSMA/CD). In this scheme, if a network station wants to transmit, it first 'listens' to the medium; if someone else is transmitting, the station defers until the medium is clear before it begins to transmit. However, two or more stations could still begin transmitting at the same time and give rise to a collision. When this happens, the two nodes detect this condition and back off for a random amount of time before making another attempt.

System considerations

Bus Latency is the maximum time between the NIC (Network Interface Controller) assertion of BREQ and the system granting BACK. This is of importance because of the finite size of the NIC's FIFO. If the bus latency becomes too great, the FIFO overflows during reception, and becomes empty during transmission. The Bus Utilization is a fraction of the time the NIC is the master of the Ethernet podule internal bus, and this should be minimised. The lowest bus utilization occurs when the bursts of data across the podule interface are as long as possible. This requires the threshold as high as possible, and Empty/Fill mode is used. The determination of the threshold is related to the maximum bus latency the system can guarantee.

A DMA set up and recovery time is associated with each burst, hence when longer bursts are used, less bus bandwidth is required to complete the same packet.

Hardware overview

The Ethernet II expansion card has been designed around the National Semiconductor Chip Set. This provides all the functions necessary to implement an IEEE 802.3 (Ethernet/thin-wire Ethernet) interface on a host computer or a peripheral device. As there is no direct DMA memory path across the podule bus, data is

transferred via a static RAM local buffer. Since both the ARM and the DMAC will have access to the Ethernet II expansion card internal bus, some arbitration is required.

Dual-port memory equivalent

This configuration makes use of the NIC's remote DMA capabilities, and requires only a local buffer memory and a bi-directional I/O port. The high priority network bandwidth is decoupled from the system bus, and the system interacts with the local buffer memory using a lower-priority bi-directional I/O port. When a packet is received, the local DMA channel transfers it into the buffer memory, part of which has been configured as the receive buffer ring. The remote DMA channel transfers the packet on a byte by byte basis to the I/O port. At this point the data is transferred through an asynchronous protocol into main memory.

Remote DMA

The remote DMA channels work in both directions; pending transmission packets are transferred into the local buffer memory, and received packets are transferred out of the local buffer memory. Transfers into the network memory are known as remote write operations, and transfers out of the local buffer memory are known as remote read operations. A special remote read operation, Send Packet, automatically removes the next packet from the receive buffer ring. Both the starting address and the length are set before initiating the remote DMA operation. The remote DMA operation begins by setting the appropriate bits in the Command Register. When the remote DMA operation is complete, the RDC bit in the Interrupt Status Register (ISR) is set and the processor receives an interrupt. When the Send Packet command is used, the controller automatically loads the starting address and byte count from the receive buffer ring for the remote read operation. Upon completion it updates the boundary pointer for the receive buffer ring. Only one remote DMA operation can be active at any time.

Hardware components

The Ethernet II expansion card can be divided into five major blocks (see *Fig 2-11: Ethernet II block diagram*). The five major blocks are as follows:

- 1 Decode and cycle access control:

Carrying out address and register decoding, control of the local buffer (latched or transparent mode) and all the required read/write signals. The type of access cycle required may be extended if bus arbitration is needed.

- 2 Podule and Ethernet identification:

A PROM containing the ID of the type of podule (expansion card) that is fitted, with the address of the

interrupt location, the Ethernet ID of the particular board (each PROM is programmed with a different number) and required driver code to run under RISC OS. It is page addressed by writing to 'mode' latch. System reset sets to page zero.

3 Data Buffer:

Static RAM memory. Memory access is completely controlled by the NIC controller which performs the memory management. Data is transferred between the controller and SRAM using local DMA, and between the SRAM and the PORT by remote DMA.

4 NIC controller:

Provides the required data rate with a minimum of control overhead. This is a key element in the design. Once set up it performs many of the Ethernet functions without requiring processor help, only producing an interrupt when a packet has been completely received or transmitted.

5 IEEE802.3 Interface Components:

Providing the Manchester encoding/decoding, high voltage isolation and line drivers for the thin-wire Ethernet interface.

Fig 2-11: Ethernet II block diagram

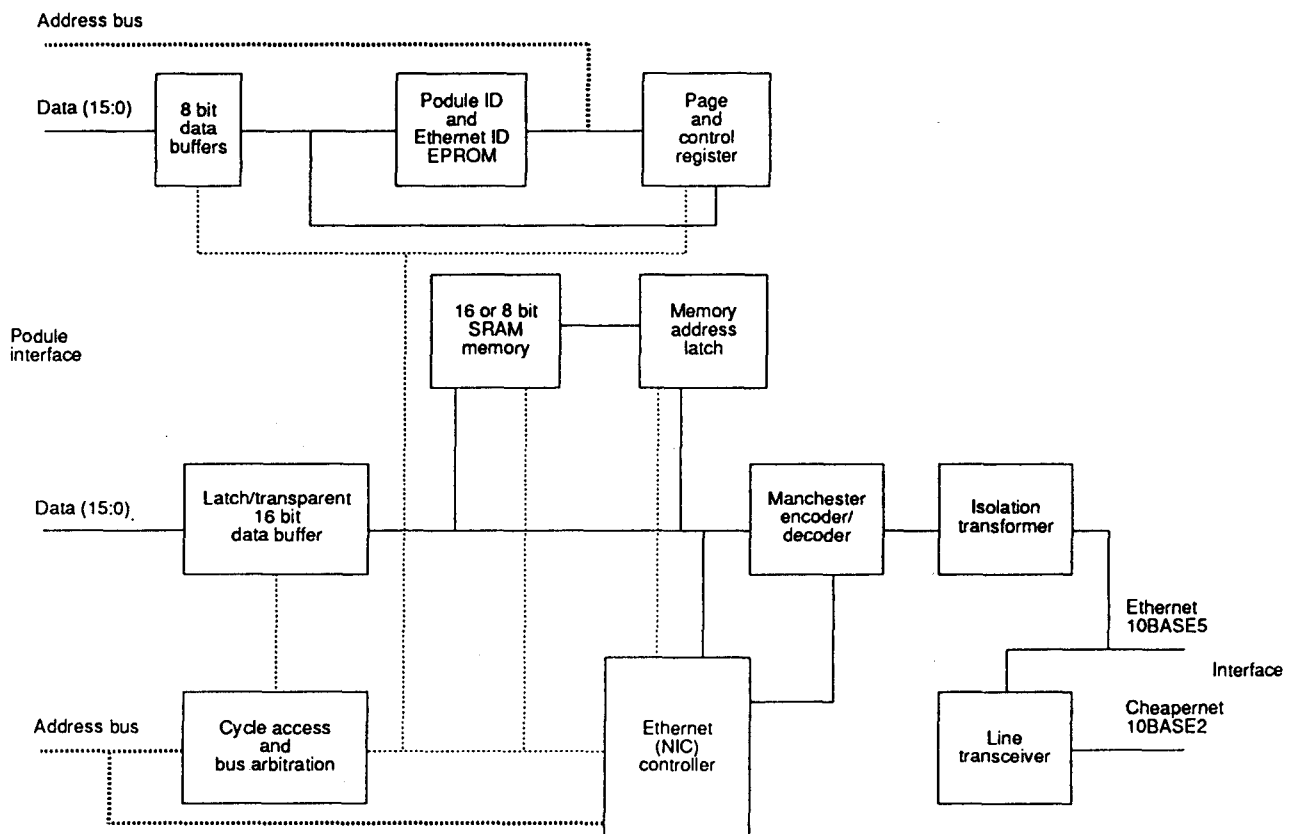

Circuit component details

Decode and cycle access control

The Ethernet II expansion card has hardware in both podule space and Module space. The podule section consists of the ID/RISC OS driver EPROM, the interrupt status register and the EPROM page register. The podule hardware is kept isolated from the Module hardware so that accesses to the Interrupt Status Register and Page Register do not affect any DMA transfers in progress on the Ethernet podule internal bus.

The podule memory map is shown below:

Address P0	LA13	LA12	use
03343000	1	1	WRITE Page Register READ not defined
03342000	1	0	WRITE not defined READ Interrupt status
03341000	0	1	SRAM test
03340000	0	0	EPROM (Paged)

The Interrupt Status register is as follows:

bit7	=	X	Not used
bit6	=	X	Not used
bit5	=	X	Not used
bit4	=	X	Not used
bit3	=	X	Not used
bit2	=	X	Not used
bit1	=	X	Not used
bit0	=		interrupt pending

When the Ethernet II expansion card generates an interrupt, the 'podule manager' will interrogate the status register (as defined by the podule ID) to check for bit 0 set active low.

In Module space the ARM has access to the Ethernet controller and the data transfer I/O Port. When a local DMA transfer between NIC and SRAM is in progress, the ARM may still access the NIC or I/O Port in the normal manner, simply by reading and writing to them. All arbitration required to gain access to the Ethernet II expansion card internal bus (when accessing the NIC) or waiting for data to be ready at the port, is carried out transparently by stretching the MEMC cycle.

The NIC has 46 registers (normally accessed using address bits RA0 through RA3 of the host processors data bus. RA0 through RA3 on the NIC are connected to LA2 through LA5) which provide the flexibility and programmability to handle both the Ethernet interface and also the interface to the local memory and controlling processor.

The I/O Port is used to transfer packets of data to and from the Ethernet/thin-wire Ethernet via the podule interface, by simply writing or reading the required data file length in 16 bit wide words. The individual bytes being

transferred automatically between the Port and Network via the NIC and SRAM.

The Module memory map address is shown below:

Address P0	LA13	LA12	use
03003000	1	1	NIC controller using LA5-LA2
03002000	1	0	Data transfer I/O Port

Podule and Ethernet identification

The ID/RISC OS driver PROM has been laid out to give from 8kB to 512kB of code space. The host cannot directly address the full PROM and therefore is operated in a page mode by writing the required page to the page register. The page register is set for page zero by power on reset. The top two bits of the page register being used for 'Lr_w' (access to the I/O Port is set for reading or writing a packet) and 'Srst' (software internal reset). The page register is not cleared by the 'software internal reset'.

The page register is as follows:

bit5	=	Srst (active low)
bit4	=	Lr_w (active high - read)
bit13	=	
bit12	=	
bit11	=	
bit10	=	
bit9	=	
bit8	=	EPROM page address bit 8
bit7	=	EPROM page address bit 7
bit6	=	EPROM page address bit 6
bit5	=	EPROM page address bit 5
bit4	=	EPROM page address bit 4
bit3	=	EPROM page address bit 3
bit2	=	EPROM page address bit 2
bit1	=	EPROM page address bit 1
bit0	=	EPROM page address bit 0

Local Buffer Memory

The buffer memory consists of two 8k x 8 (up to 512k x 8 for SRAM source flexibility) static RAMs which give a 16 bit data transfer across the podule interface, hence maximizing the podule bandwidth. The data buffer is completely controlled by the NIC controller, which performs all the memory management in a ring buffer format. Pointers to the memory are updated as required (but can be accessed via the NIC registers if necessary). The data buffer is transparent as far as data transfers across the podule interface are concerned.

NIC Controller

The National Semiconductor Network Interface Controller provides all the functions necessary to implement all Media Access Control (MAC) layer functions for transmission and reception of packets in accordance with the IEEE 802.3 standard. All bus arbitration and memory support logic and two DMA channels are integrated into the NIC. The local DMA channel transfers data between the internal controller FIFO and local memory. On transmission, the packet is transferred from local memory to the FIFO in bursts. Should a collision occur, the packet is re-transmitted with no processor intervention. On reception, packets are transferred from the FIFO to the receive buffer ring. A remote DMA channel is provided to transfer between local buffer memory and system memory. Full details for operating the NIC are contained in the data book (see the section entitled *Bibliography* on page 2-17).

IEEE802.3 Interface Components

These are the components concerned with the Ethernet/Thin-wire Ethernet interface. They include the 20MHz oscillator (providing the required transmit and receive clock), the Manchester encoder/decoder, DP8391 (to produce the required signals), the transceiver/line drivers, DP8392 (required to provide thin-wire Ethernet signals) and components to provide isolation such as the DC to DC convertor, line transformers, termination resistors, capacitors and a diode as required.

PALs

There are four PALs used:

- Decode
- Intbuf
- Memcpal
- Natfix.

Decode (0273,271)

As its name suggests, this PAL decodes podule and module addresses to produce chip select signals. It enables reading of the EPROM, writing to the page register, reading interrupt status, and read/write operations to the NIC controller main podule interface functions. It also defines whether podule or DMAC have control of the bus. The PAL's function is shown by the state flow diagram below.

Intbuf (0273,272)

The 'intbuf' PAL, in conjunction with the 'memcpal' PAL, form the core to the Ethernet podule bus arbitration logic. Intbuf produces the interrupt control and all the functions required to control the I/O Port (HCT646s, which are used in both latched and transparent mode, depending on the type of access active).

Memcpal (0273,273)

The 'memcpal' PAL, working in conjunction with the 'intbuf' PAL, produces all the podule interface (MEMC) required read and write pulses. The Ethernet controller has two main modes of operation – Bus Master (while performing DMA) and Bus Slave (while its internal registers are being accessed). These two modes require two different types of access cycle (a different bus arbitration is used). Within these two modes a read or a write cycle may be in operation. The PAL's function is shown by the state diagram overleaf

The internal reset will set this PAL to the 'Idle' state. It remains in this state until a MEMC cycle is decoded. From the 'Idle' state it may enter one of four states:

- Slave Read
- Slave Write
- Master Read
- Master Write.

On entry to one of these states, a complete cycle will follow. Whichever state it has entered, it will remain in that state while the bus arbitration function is completed. Once access has been granted, the cycle continues, producing read or write pulses and MEMC signals (including waiting during interrupts) as required.

Natfix (0273,274)

The National Semiconductor NIC Ethernet controller requires care to be taken when trying to access its internal registers via the control signal Chip Select. The PAL Natfix is used to monitor the controller's use of the bus and then hold back any access to the registers while the controller is using the bus. It similarly holds back the controller during a register access, and has the effect of making sure that Chip Select doesn't become active on a rising edge of the 20MHz clock.

Summary

The Ethernet II expansion card hardware design tries to be as transparent, in terms of data transfer, as possible. Where design requirements have allowed, flexibility has been given to the way the software can use this hardware platform, at the same time trying to maintain minimum system overhead. Much of the flexibility of the design is achieved by the use of the DP8390 (NIC), which is a complicated device containing several internal registers allowing software to dictate operation. Therefore access to the Ethernet/Cheapernet LAN is achieved by software drivers that firstly prime the device by direct access and then leave the expansion card to run free, requiring only burst data transfers across the podule interface, an interrupt being used when intervention is required.

Bibliography

The following publications will be of interest to technicians and users wanting to find out more about Ethernet and the Acorn Ethernet II card:

- ANSI/IEEE Std 802.3 -- 1985 ISO draft International Standard 8802/3 ISBN 0-471-82749-5, Carrier Sense Multiple Access with Collision Detection (CSMA/CD) access method and physical layer specifications.
- National Semiconductor data sheet for the DP8390C NIC. In the National Semiconductor Data Communications, Local Area Networks and UARTs Advanced Peripherals Handbook, available from National Semiconductor (UK) Ltd, 301 Harpur Centre, Horne Lane, Bedford MK40 1TR.
- 'A-series Podules', specification issue 2.0, available as an application note from Acorn Computers Limited (address at the front of this manual).

Fig 2-12: Ethernet/Cheapernet links

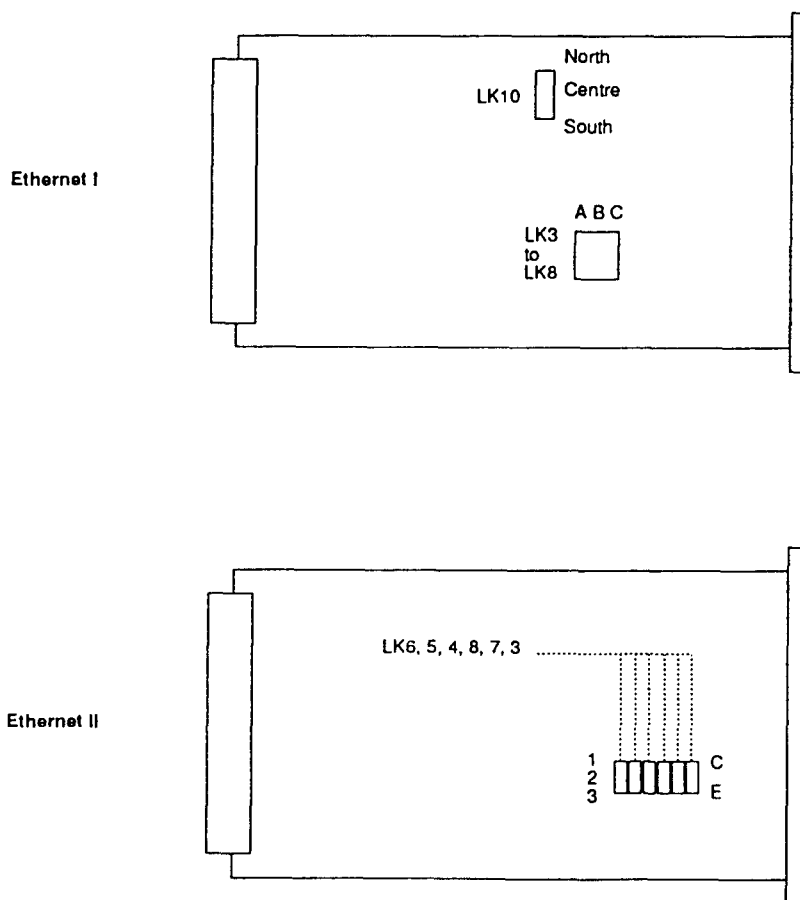

SCSI interface

Overview

Workstation models which provide a SCSI interface do so by means of a SCSI expansion card (*Podule*) plugged into an expansion slot in the backplane.

The Small Computer System Interface (SCSI) is a high-speed interface for use mainly with mass storage devices such as hard discs, tape drives or CDs. It is an asynchronous bus capable of data transfer rates up to 4MB per second. The bus cable is a 50 way cable consisting of:

- 30 Ground wires
- 9 Control signals
- 8 Data signals
- 1 Data parity signal
- 1 Terminator power line
- 1 Not Connected.

The pin allocation for the two standard SCSI bus connectors can be seen on the schematic.

Communication on the bus is between two devices, an initiator and a target. In the most common case the initiator will be the host computer and the target will be a hard disc drive. The first task for the initiator is to select the required target. There can be up to eight devices on a single SCSI bus, each having its own unique select code.

This select code is simply a different single bit of the data bus allocated to each device on the SCSI bus. Generally the host computer uses select code seven (data bit 7) and the first target will use select code zero (data bit 0).

Having selected its target, the host then transfers a small group of bytes known as the Command Descriptor Block (CDB) to the target. The CDB defines the action to be taken by the target. In the case of a disc drive this will usually be to send some data to the host, or to receive some data from the host and write it onto disc.

The SCSI bus will go through many 'Phases' during the execution of such a command and the target may even release the bus (or 'Disconnect') during the execution of a command (for example if a 'Seek' is required by a hard disc drive), thus allowing the host (or initiator) to initiate commands on other targets.

The complexities of SCSI Bus Phases, handling target disconnections etc, can be all taken care of by single chip SCSI controllers.

For further details of the functions of the SCSI bus, refer to the ANSI Standard X3.131-1986 and the data sheet for the SCSI controller used in the Acorn SCSI expansion card (see the section entitled *Bibliography* on page 2-23).

Circuit description of the SCSI expansion card (Issue 2+)

Maximum performance is achieved from the Acorn expansion bus by the use of the STM (STore Multiple) and LDM (LoaD Multiple) ARM assembler instructions to transfer data to and from a peripheral device. These instructions, coupled with the full use of the 16 bit I/O data bus, will provide a maximum data transfer rate of 8 MB per second. Unfortunately these commands cannot be used to transfer data to and from the SCSI controller chip directly, because it cannot be predicted whether or not the WD33C93A (the device used in this design) can accept or provide the mandatory number of bytes for the relevant instruction.

Furthermore, the WD33C93A is an 8 bit device, hence some kind of funnel hardware is required to couple the 8 bit bus to the 16 bit I/O bus.

The solution to these problems is to have buffer memory on the expansion card, accessible by both the WD33C93A and the ARM processor. This dual porting of the buffer memory is the most complex aspect of the circuit and is therefore dealt with separately.

The main elements of the SCSI Expansion card are:-

- Western Digital WD33C93A SCSI Bus Controller
- NEC 71071 DMA Controller
- two 32K by 8 bit Static RAMs
- EPROM containing the driver software
- four PAL devices controlling ARM access to the card
- SCSI bus connector, termination resistor packs, and filters
- data and address bus buffers and latches.

The SCSI Expansion Card (SEC) has hardware in both Podule (expansion card) I/O space and Module I/O space. The podule section consists of the ID/RISC_OS driver EPROM, the interrupt status register and the EPROM page register. This page register is also used for the SRAM (Static RAM buffer memory) page. The podule hardware is kept isolated from the Module hardware to allow accesses to the Interrupt Status Register (ISR) and the Memory Page Register (MPR) not to interfere with any DMA process that may be taking place between the SCSI Bus Interface Controller (SBIC) and the SRAM.

The EPROM circuit permits from 8 KB up to 128 KB of code space, the top two bits of the MPR being used for interrupt enable (IE) and user reset (UR). The IE is 0 by default and has to be set to 1 before any interrupts can be generated by the SEC. The UR bit is also 0 by default and if set to 1 will cause the internal reset line (IRST) in the SEC to become active. The DMAC has a minimum reset period of 21CYK (250ns) and the SBIC has a minimum reset period of 1µs. The MPR is not cleared by the IRST signal. A link option does allow the SCSI bus reset to control the IRST, should the card be required to act as a target. The SBIC will inform the host processor that a reset has occurred.

The final section of the podule hardware is the interrupt control logic. There are two sources of interrupts within the SEC, the DMAC and the SBIC. The DMAC will issue a terminal count (TC) pulse at the end of a data transfer which will be latched by the ISR, and may be subsequently read at any time by the ARM processor. SBIC interrupts are latched within the SBIC, but can be monitored in the ISR. DMAC interrupts remain latched until the Clear Interrupt (CLRINT) address is written to. SBIC interrupts remain latched until appropriate action is taken by the host. The two interrupt sources are combined in a PAL to form a common PIRQ.

The address map for podule slot 0 fast access is given below:

Address P0	LA13	LA12	Use
03343000	1	1	Write MPR, UR, IE Read not defined
03342000	1	0	
03341000	0	1	EPROM (Read Only) Paged address
03340000	0	0	

Bit	MPR Bit Allocation	ISR Bit Allocation
7	1 = User Reset	X Not used
6	1 = Interrupts Enabled	X Not used
5	EPROM Page Address	X Not used
4	EPROM/SRAM Page Address	X Not used
3	EPROM/SRAM Page Address	1 = SBIC Interrupt
2	EPROM/SRAM Page Address	X Not Used
1	EPROM/SRAM Page Address	1 = DMAC Terminal Count Interrupt
0	EPROM/SRAM Page Address	1 = SEC Requesting IRQ

In Module address space the ARM has access to the SRAM via a 16 bit data bus and addresses it as 16 4KB pages (8K addresses 16 bits wide, every 4th address), using the MPR located in podule address space.

LA2 of the podule bus is connected to A0 of the SRAM, so that the lower 16 bits of the ARM registers will be stored in consecutive addresses when an STM instruction is used.

The DMAC and the SBIC are also memory mapped but only have 8 bit data buses. The DMAC has many registers which are normally accessed using address bits A0 through A7 of the host processor address bus. Due to the funnelling required to exchange data between 8 bit

and 16 bit data buses, the DMAC addressing has had to be mapped rather unusually. A1 through A7 on the DMAC are connected to LA2 through LA8, and A0 on the DMAC is connected to LA9.

Thus the mapping becomes:

Normal Offset	SEC Offset	Register
0000	0000	Initialise
0001	0200	Select Channel to Program
0002	0004	Transfer Count Low
0003	0204	Transfer Count High
0004	0008	Transfer Address Low
0005	0208	Transfer Address Mid
0006	000C	Transfer Address High
0007		Unused
0008	0010	Device Control Register 1
0009	0210	Device Control Register 2
000A	0014	Mode Control Register
000B	0214	Status Register
000C	0018	Temporary Register Low
000D	0218	Temporary Register High
000E	001C	Request Register
000F	021C	Mask Register

The SBIC is used in the indirect addressing mode where LA2 is used as A0 to select between control registers and the address register (see data sheet).

When a DMA transfer between SBIC and SRAM is in progress, the ARM may still access the DMAC, SBIC or SRAM in the normal manner simply by reading or writing to the appropriate address. All arbitration required to gain access to the SEC internal buses is carried out transparently by stretching the MEMC I/O cycle (see the podule bus specification). In the case of an STM and LDM instruction only the first access is stretched to gain control of the SEC buses. The ARM will normally retain control of the SEC buses during video DMA interruptions.

Module Address Map:

Address P0	LA13	LA12	Use
03003000	1	1	DMAC (LA9 – LA2)
03002000	1	0	
03001000	0	1	SRAM (Page addressed)
03000000	0	0	

SRAM paging is exactly the same as EPROM paging.

Component identification on the SEC

EPROM address lines from the ARM podule bus are unbuffered. This allows them to operate during DMA. The extra address lines are provided by the MPR (IC17

HCT273), which are directly connected to the EPROM, but isolated from the SRAMs by IC3 (HCT541). The EPROM (IC5) and the ISR (IC15, PAL 0273,215) also have an 8 bit data bus buffer (IC2 HC245) separate from that used for the SRAMs, DMAC and SBIC. Again, this allows ARM access independent of DMA activity. IC4 (HC245) and IC6 (HC245) provide 16 bits of data bus buffering for the SRAMs (IC13 and IC11), as well as the DMAC and SBIC. IC7 (HCT573) is used to hold the upper 8 address bits for the DMAC during DMA transfers, and IC8 (HC245) routes the data to the correct SRAM, depending on the state of A0. The DMAC 'sees' the SRAM as 64K by 8 bits, whereas the ARM 'sees' the SRAM as 32K by 16 bits. IC17 (uPD71071) is the DMAC and IC16 (WD33C93A) is the SBIC.

All address decoding is taken care of by IC9 (PAL 0273,216). The task of arbitration for access to the SRAM is shared by IC15 (PAL 0273,213) and IC14 (PAL 0273,217), IC18 (PAL 0273,219), and IC12 (PAL 0273,218). IC15 [IC14] also generates the IOGT and BL signals required by the podule Bus, while IC12 handles the I/O and memory read and write lines (IORD, IOWR, MEMR, MEMW). There are various link options on the SEC and they are listed below:

Issue 2+ expansion card:

EPROM size select						
EPROM	LK1	LK2	LK3	LK4	LK5	LK7
27128	C	O	O	O	C	C
27256	O	O	O	C	C	C
27512	O	C	O	C	O	C
27C101	O	C	C	C	O	O

O - Open C - Closed

Factory fitted links set the size of the Issue 2+ PCB to 27256.

LK6 and LK7 allow the DMAC to perform memory-to-memory transfers.

LK8 and LK9 allow for larger SRAM devices, but these could not be fully addressed by the ARM processor.

LK10 and LK11 switch the reset line for initiator or target mode:

Mode	LK10	LK11
Initiator	O	C
target	C	O

The PCB is factory configured for initiator mode.

The SCSI bus signals are connected from the SCSI bus connector to the SBIC, via filter capacitors clearly visible on the circuit board. The SCSI bus requires termination at each end of the bus cable on all signal lines. These are 220R to +5 volts and 330R to 0 volts. Where no internal

drive is fitted, termination is provided internally by a plug-on terminator PCB assembly, which is mechanically polarised. Power to these termination resistors is provided via diode D1, to allow target devices on the SCSI bus to power them should the initiator be switched off. The initiator may also power the terminators at the far end of the SCSI bus cable. Fuse FS1 limits the current to a maximum of 1 Amp. TR1 provides an open-collector drive to the SCSI reset signal when the SEC is used in initiator mode.

The SCSI expansion card state machine

When the ARM system memory clock is run at a different speed from that of the I/O clock, a period of synchronization (minimum 1 I/O clock cycle) is required at the beginning and end of each I/O cycle. These extra clock cycles cause the earlier SEC design to relinquish and re-arbitrate for SRAM access on every register transfer of an STM or LDM command, degrading potential performance. The solution to this was to cause the Issue 2+ state machine to hold access to the SRAM for the ARM for a number of clock cycles after the completion of the I/O cycle. This allows for synchronisation clock cycles and will, conveniently, span video DMA interruptions too. This is achieved by the use of a three bit counter built in to the RWPAL and count decode logic in the new PAL ADDPLUS. *Figure 2-13* shows two accesses to the SBIC. The first access is a write to the address register in order to pre-select a register. The second is a register read. Note that because LA13 is high the second access is an E-cycle, even though the ARM has control. *Figure 2-14* shows an LDM from SRAM. Note that LA13 is low throughout this command. When the extended cycle is complete the RW_DN signal is activated and the counter starts to count from zero again. However, each time an IORQ is received, it is reset to zero. Hence we see the counter oscillating between zero and one until the end of the LDM, when it counts out to seven, and the bus control is relinquished. *Figure 2-15* shows an STM split up by video DMA accesses and the counter reaching a higher count before being reset to zero.

Figure 2-13

Figure 2-14

Figure 2-15

Glossary of terms for PAL signal names

SCSI	Small computer systems interface	REF8M	Reference 8MHz clock
SBIC	SCSI bus interface controller	MEMW	Memory write
DMAC	Direct memory access controller	C2	Counter bit 2
SRAM	Static random access memory	C1	Counter bit 1
		C0	Counter bit 0
PCLK8M	8MHz clock	IOWR	I/O device write
CLRINT	Clear interrupt	IORD	I/O device read
INTE	Interrupt enable	I/O	Input/Output
TC	Terminal count	MEMR	Memory read
INTRQ	Interrupt request	CNTR0	Counter bit 0
ARMA	ARM processor access	CNTR1	Counter bit 1
MS	Module select	CNTR2	Counter bit 2
URST	User reset	RWD	Read write done
RST	Reset	B**	Buffered 'signal'
ABE	ARM bus enable	UDE	Upper data enable
IRST	Internal reset	NC	Not connected
IRQ	Interrupt request		
DINT	DMA interrupt		
FIQ	Fast interrupt		
SINT	SCSI interrupt		
SRST	SCSI reset		
PIRQ	Podule interrupt		
PRE	Podule read enable		
PWE	Podule write enable		
LA12	Latched address 12		
LA13	Latched address 13		
PS	Podule select		
DACK	DMA acknowledge		
A0	Address line 0		
A23	Address line 23		
EPRM	EPROM		
SRLO	Static RAM low		
SRHI	Static RAM high		
PAGE	Page register		
INTRD	Interrupt read		
AEN	Address enable		
IORQ	Input/output request		
HLDRQ	Hold request		
STAGE	Move to next stage		
PNRW	Podule not read, write		
BL	Buffer latch		
LBL	Latched buffer latch		
LIOGT	Latched IOGT		
REL	Release		
EXTRW	Extended read write		
HLDK	Hold acknowledge		
IOGT	Input output grant		
RA7	SRAM address 7		

Bibliography

- WD33C93A SCSI Bus Interface Controller Data Book (document no. 79-000199). Available from Western Digital (UK) Ltd, The Old Manor House, 17 West Street, Epsom, Surrey KT18 7RL.
- NEC Microprocessor and Peripheral Data Book, covering the uPD71071 DMA controller. Available from NEC Electronics (UK) Ltd, Cygnus House, Linford Wood Business Centre, Sunrise Parkway, Linford Wood, Milton Keynes MK14 6NP.
- 'A Series Podules' - a specification of the Acorn podule bus, available as an Application Note from Customer Services (address as at the front of this manual).
- Acorn *SCSI Expansion Card User Guide*, supplied with the SCSI expansion card.

Part 3 - Disassembly and assembly

DANGER:

BEFORE REMOVING THE TOP COVER, ENSURE THAT THE COMPUTER SYSTEM HAS BEEN SWITCHED OFF AND THE MAINS PLUG REMOVED FROM THE SUPPLY.

REMOVING THE TOP COVER GIVES ACCESS TO THE POWER SUPPLY. ALTHOUGH THE POWER SUPPLY IS DESIGNED TO COMPLY WITH BS5850 CLASS 1, YOU MUST STILL TAKE CARE TO ENSURE THAT NO METAL OBJECTS FALL (OR ARE PUT) INTO THE POWER SUPPLY UNIT THROUGH THE VENTILATION HOLES.

NOTE:

STRINGENT ANTI-STATIC PRECAUTIONS MUST BE TAKEN ONCE YOU HAVE REMOVED THE TOP COVER.

Introduction

This chapter tells you how to break down a standard A540 or R260 computer into its serviceable modules, in order to carry out basic checks and replace modules found to be faulty.

It is recommended that you remove modules in the order given in this chapter, to ensure, for instance, that no cables are left connected to the particular item you wish to remove.

The main unit houses the following:

- SCSI podule (and the Econet podule, in some cases)
- Backplane
- RAM and ARM cards
- Main PCB
- 3.5" floppy disc drive
- Hard disc drive
- PSU.

The keyboard, mouse and monitor are separate units.

See the appropriate third-party service information for the monitor. The mouse is a service replacement only item.

This chapter makes reference (when it gives item numbers) to the final assembly drawings (part number 0086,000/A sheets 1 and 2) which you will find at the back of this manual.

Note on R225 model

Disassembly for the R225 is mostly the same as for the A540/R260 models. Where there are physical differences (ie not just different item numbers) these will be noted in the relevant sections in this chapter.

Removing the top cover

- 1 Switch off and disconnect the computer from the mains supply and the disconnect all peripherals, including the keyboard.
- 2 Place the main unit, with the rear panel facing you, on a work surface with a clean, soft covering.
- 3 Remove the top cover:

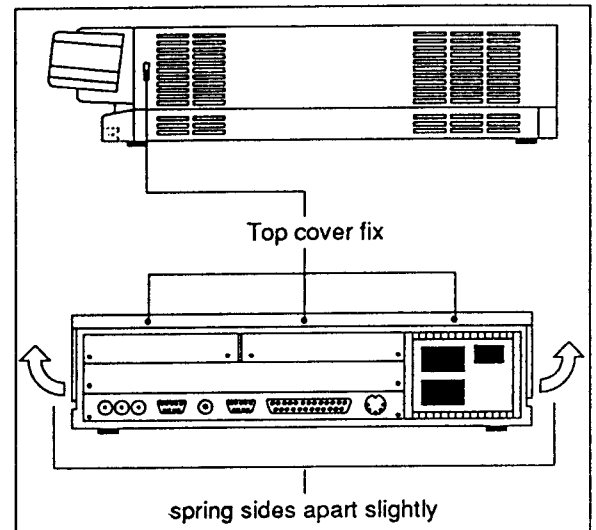

- Remove the two screws in the sides of the top cover, immediately behind the front moulding.
- Remove the three screws along the top of the rear panel and remove the top cover by sliding it off from the rear of the unit. You may need to spring the sides apart slightly to make this easier.

Removing the SCSI podule

- 1 Remove the SCSI data cable (item 44) from the SCSI PCB (item 4).
- 2 Remove the SCSI PCB and the blanking panel (item 15) by removing two screws and washers (items 52 and 62).
- 3 Disconnect the SCSI PCB from the backplane.
- 4 Remove the double-width blanking panel (item 13) by removing two screws and washers (items 52 and 62).
- 5 Remove the SCSI podule from the T piece (item 16).

Note1: Some models may also be fitted with an Econet podule as standard. You can remove this at the same time as the SCSI podule.

Note2: R225 models are not fitted with a SCSI podule. However, they are fitted with a ROM podule and an Ethernet podule. To remove these, follow steps 2 to 5 above.

Note 3: Carefully store any PCBs, ensuring that all anti-static precautions are taken.

Removing cables

Note: On an R225, ignore references to cables attached to hard or floppy drives

- 1 Disconnect the cables from the following plugs on the main board:
 - PL4 (floppy drive controller cable)
 - PL2 (floppy drive power cable)
 - PL5 (PSU power cable)
- 2 Remove the hard disc power cable from the rear of the hard disc drive.
- 3 Disconnect the twisted pair leads for the speaker and the green power-on LED by removing the connectors from LK13 and LK14 on the main board.
- 4 Unbolt the PCB earth strap (item 42) from the drive saddle (item 25) by removing a nut and washer (items 59 and 65). Lift the earth strap clear.

Removing the backplane

- 1 Remove two screws and washers (items 53 and 61) from the backplane support bar (item 37).
- 2 Remove the backplane from the main board connector SK9.

Removing the RAM and ARM cards

- 1 Remove any RAM cards from the sockets SK5, 6 and 7 on the main board. (Not fitted to R225 or A540 models).
- 2 Remove the ARM3 (PGA) PCB (item 49) from PL3 on the main board, and remove the backplane insulation sheet (item 40).

Note: carefully store the PCBs, ensuring that all anti-static precautions are taken.

Removing the main PCB

- 1 Remove the two PCB backplate retaining screws and washers (items 52 and 62) from the rear of the unit.
- 2 Carefully slide the main PCB out from the rear of the unit.

Note: carefully store the main PCB, ensuring that all anti-static precautions are taken.

Removing the front moulding assembly

- 1 Remove the two screws (item 55) securing the front moulding assembly (item 7) at each side.

- 2 Stand the unit on one side and remove from the underside the three screws (item 56) securing the front moulding assembly to the base metalwork (item 10).
- 3 Stand the unit back on its feet, grasp the front moulding assembly at each end and use a straight, steady pull to withdraw it **half way** from the front of the unit.
- 4 Disconnect the amber LED cable (item 45) from the front of the hard disc drive (item 80).
- 5 Completely remove the front moulding assembly.
- 6 For access to the indicator LEDs, locate and remove the two self-tapping screws (item 56) at each end inside the main front moulding and slide the sub-moulding (item 21) away from the main moulding.

Removing the floppy disc drive

- 1 Remove the floppy disc drive (item 22) complete with the floppy drive bracket (item 24) by unscrewing two screws (item 57) and plain washers (item 61) securing the drive bracket to the drive saddle (item 25).
- 2 Lift the drive and bracket clear from the case.

Note: There is no floppy drive fitted to R225 models, but the drive bracket is still present (to add rigidity to the structure).

Removing the hard disc drive

- 1 Remove the SCSI hard disc drive (item 80) complete with the hard disc bracket (item 39) by unscrewing the two securing screws (item 57).
 - 2 Lift the drive and bracket clear from the case.
- Note:** There is no hard disc fitted to R225 models

Removing the power supply unit

CAUTION: DOUBLE POLE/NEUTRAL FUSING
The PSU is fitted with a double-pole switch and both the Live and Neutral lines are fused.

- 1 Turn the unit on its side and remove the four fixing screws and washers (items 53 and 63) from the underside of the base metalwork.
- 2 Stand the unit back on its feet, and slide the PSU (item 31) forward to clear the rear moulding, then lift it clear.

Note 1: When installing a PSU, the system should be tested for satisfactory earth continuity in accordance with BS7002/EN60950.

Note 2: The PSU is a service replacement only item.

DANGER:
WHEN REFITTING OR FITTING A REPLACEMENT ASSEMBLY, CHECKS SHOULD BE MADE FOR EARTH CONTINUITY BETWEEN THE EARTH PIN OF THE MAINS PLUG AND THE FOLLOWING:

- THE BASE METALWORK
- THE REAR PANELS (INCLUDING BLANKING PANELS)
- THE TOP COVER

USE AN EARTH CONTINUITY TESTER SET TO 25 AMPS.

Assembly

Keyboard assembly is generally in reverse order, with the following notes:

Slot the PCB support tray under the two fixing screws at the end furthest from the keyboard cable, then insert the remaining screws. Check that all keys clear the cutouts in the top moulding before finally tightening all PCB fixing screws.

Mouse

The mouse is a service replacement only item.

Main unit assembly

Assembly is generally the reverse of the disassembly procedures, but take care with the routing of cables and ensure that leads are not trapped when refitting assemblies to the main unit.

Keyboard

The computer may be fitted with either one of two keyboards:

- Panasonic (fitted on most models)
- Keytronic (on some early models).

Both keyboards are identical on the exterior; they only differ internally, in that they have different PCBs.

Disassembly

- 1 Invert the keyboard and place it on a soft, level surface.
- 2 Remove the eight cross-headed screws securing the two halves of the case and carefully lift the base moulding away.
- 3 The PCB in the Keytronic keyboard is fixed to the top moulding by six No. 6 x 0.25" screws.
The PCB in the Panasonic keyboard is fixed to the top moulding directly by four screws, and also by means of two metal brackets (with four screws and washers).
For the Panasonic keyboard, first remove the two screws and washers fixing the brackets to the top moulding, then remove the remaining screws fixing the PCB directly to the moulding (you can leave the brackets attached to the PCB).
For the Keytronic keyboard, remove the six screws fixing the PCB to the top moulding.
- 4 Note that the reset switch cap must be removed from the original keyboard and fitted to the replacement.

Part 4 - Fault diagnosis

This chapter is a guide to the diagnosis and repair of basic faults in the Archimedes 500 series and R200 series computer systems.

It consists of algorithms to enable you to trace and remedy faults in a 'dead' computer, followed by instructions for running the Archimedes functional test software, which is designed to isolate faults in a computer which is working.

Part 5 - Main PCB fault diagnosis is designed to help repair centres to diagnose and repair faults at component level on the main PCB.

Note 1: It is a good idea to familiarise yourself with the tests by performing them on a known working computer.

Note 2: Throughout this chapter the acronym UUT is used to mean Unit Under Test.

Test equipment required

- 100 MHz Oscilloscope
- DC Voltmeter
- test discs:
 - dealer test disc (Acorn part number 0286,832)
 - hard disc initialiser test disc (0286,822)
- test SCSI hard disc (see the section entitled *Creating a test SCSI hard disc* on page 4-5)
- serial port loopback plug – see *Appendix C - Serial port loopback plug*
- headphones (32 ohm impedance)
- analogue multisync colour monitor (suitable for super VGA)
- hi-resolution monochrome monitor
- Epson FX80 compatible printer (Olivetti JP101 or Epson FX80)
- 3 x blank 800K ADFS E format write-enabled, 3.5 inch floppy discs:
 - *data disc* – for storing customer CMOS RAM configuration data
 - *CMOS RAM test data disc* – for storing the manufacturer's default CMOS RAM settings (see the section entitled *Creating a CMOS test data file* on page 4-6)
 - *scratch disc* – used in the disc interface test
- working keyboard (0086,900/A)
- working backplane (0186,001)
- working SCSI card (0173,010 Issue 2+)
- mouse test jig template (see *Appendix A - Mouse test jig template*)
- chip extraction tool (68/84 pin)
- standard hand tools, such as screwdrivers and pliers
- earth testers (see *Appendix D - Earth continuity testing*)
- isolation tester (see *Appendix E - DC Insulation testing - class 1*).

Additional test equipment required when testing expansion cards

You will need the following additional equipment when testing expansion cards:

ROM expansion card test:

- ROM Podule Guide (0476,220)
- EPROM (0276,230-01)
- EPROM FS (0276,221) required if not fitted.

IO expansion card + MIDI expansion card test:

- a known working MIDI expansion card (0176,280)
- IO port tester assembly (0233,020) from which only the following parts are needed:
 - port tester main PCB
 - 34way IDC skt to 34way IDC skt cable assembly
 - 20way IDC skt to 20way IDC skt cable assembly
 - 15way IDC D type plug to 15way IDC D type plug assembly
- Acorn Econet cable – 2 off.

MIDI expansion card test:

- a second, known good, MIDI expansion card
- 2 Acorn Econet cables (which have been labelled IN and O/P)

Ethernet I and II expansion card tests:

- Ethernet I and II test feedback leads – see *Appendix B - Ethernet test feedback leads* (you will need to make these)
- Ethernet T-piece
- Ethernet terminators – 2 off.

Anti-static precautions must be used at all levels of servicing, ie antistatic matting and wrist-straps.

Refer to *Part 3 - Disassembly and assembly* for information on how to gain access to the components mentioned.

DANGER:

WHEN REFITTING OR FITTING A REPLACEMENT ASSEMBLY, CHECKS SHOULD BE MADE FOR EARTH CONTINUITY BETWEEN THE EARTH PIN OF THE MAINS PLUG AND THE FOLLOWING:

- THE BASE METALWORK
- THE REAR PANELS (INCLUDING BLANKING PANELS AND CONNECTING PLATE)
- THE TOP COVER

USE AN EARTH CONTINUITY TESTER SET TO 25 AMPS. REFER TO *Appendix D - Earth continuity testing*.

Checking a 'dead' computer

This section covers the initial tests that you should perform on an apparently 'dead' computer to discover which module or upgrade is faulty. If the computer is partially working (ie any faults occur after a successful power-up) go straight to the section entitled *Functional testing* on page 4-4.

Follow the instructions shown in the flow chart opposite.

Notes:

- 1 You may need to reconfigure the CMOS RAM to its original (factory) default. Make sure that the customer is made aware of this.
- 2 Before replacing any of the units as described below, switch off and unplug both the monitor and computer.

What to do next

In most cases you can now use the test software described in the section entitled *Functional testing* on page 4-4 to check for and correct any other faults. The two main exceptions to this are:

- when a fault within the keyboard prevents the dealer test disc from auto-booting – in which case exchange the keyboard
- when there is a floppy disc drive fault, and the test software will not load from a known working dealer test disc – in this case, exchange the disc drive.

If, after all the above tests, the computer still fails to power-up and provide a screen display, return the entire computer (with all original modules fitted) to an Acorn central service facility for repair.

DANGER:

BEFORE ATTEMPTING TO OPEN THE COMPUTER, OR EXCHANGE EITHER THE PSU OR PCB, ENSURE THAT YOU HAVE READ AND FULLY UNDERSTOOD ALL THE INSTRUCTIONS IN *Part 3 - Disassembly and assembly*. UNDER NO CIRCUMSTANCES SHOULD ANY ATTEMPT BE MADE TO REPAIR OR MODIFY THE PSU. ANY ATTEMPT TO DO SO WILL INVALIDATE THE ORIGINAL SAFETY TESTS APPLIED AT MANUFACTURE AND MAY CREATE A SAFETY HAZARD.

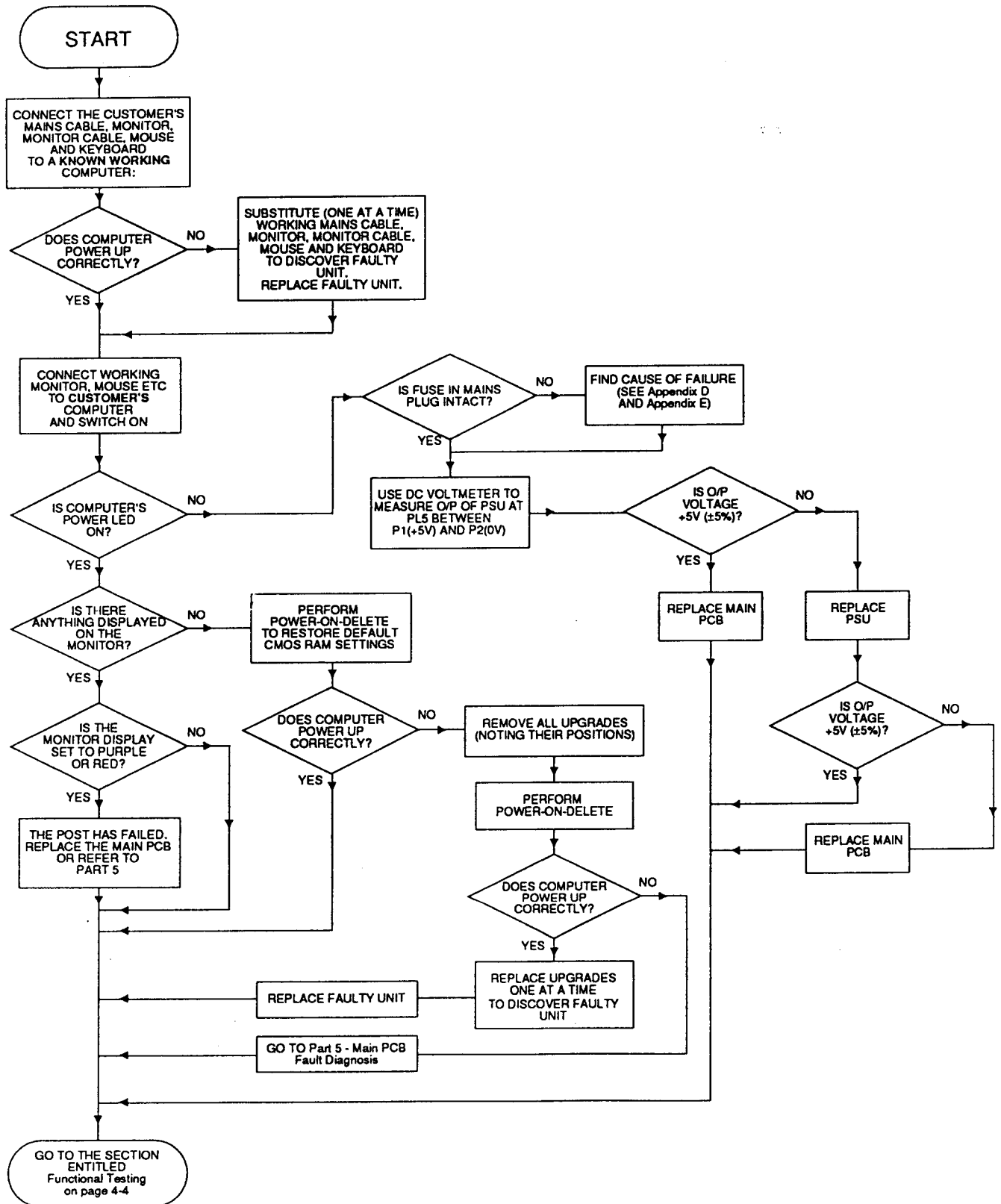

Functional testing

The following information gives details of how to isolate faults to individual modules, using the dealer test disc (0286,832) on machines which are running, but exhibiting faults. The tests included on the disc can be divided into two groups as follows:

- Test suite – includes everything needed for testing a standard configuration machine. The tests run automatically, in sequence – see the section entitled *Main PCB functional test suite* on page 4-7.
- Individual tests – for testing an individual module, expansion card, or upgrade (ie only the memory) – see the section entitled *Individual tests* on page 4-15.

Note 1: Please read the section entitled *The dealer test disc* before you carry out any of the tests.

Note 2: For details of how to repair the main PCB, see *Part 5 - Main PCB fault diagnosis*.

The dealer test disc

This test disc (0286,832) contains various menu-driven tests. The menus are generated from a set of text files. You can generate new text files if you wish. The menu option you select determines the test to be executed. To select an option, type the corresponding letter. Some options lead to further menus, other options run tests immediately.

There are two types of test:

- subjective – you must judge whether the equipment passes or fails these tests. For this reason it is a good idea for you to familiarise yourself with the correct results given by a known good computer. In this way you will be in a better position to judge faulty results.
- non-subjective – the test program passes or fails the equipment.

General test procedure

IMPORTANT

Before you start testing, make a backup copy of the test discs (0286,832 and 0286,822).

All items should be complete with the correct cables so that you can connect them to the Archimedes computer.

Safety

Some of these tests require that you remove the top cover of the Archimedes computer. Although the power supply unit is designed to comply with BS5850 Class 1, you must still take care to ensure that no metal objects fall (or are put) into the power supply unit through the ventilation holes.

Notes:

- 1 You must only connect the power AFTER you have made all the other connections.
- 2 You must switch off the equipment and disconnect from the mains supply BEFORE removing any other connections.

You will find instructions for removing the top cover in *Part 3 - Disassembly and assembly*

Before you start

Before carrying out any of the tests in this chapter, validate the test equipment using a known good unit. If the test equipment fails, you should repair the test equipment and retest on a known good unit.

Ensure that you

- adjust the colour monitor to produce adequate contrast
- inspect all the mechanical parts of the test equipment and replace any parts as necessary.

Also, if required:

- ensure that the printer has sufficient paper
- connect the printer and monitor to the mains supply.

Do NOT turn on.

Error messages

If a message is expected and has not appeared within 30 seconds, you must record the fault, switch off the machine and repair before retesting.

If a test fails, then you should record the fault and attempt to continue with the tests. You should also note any other failures, but bear in mind the possibility that these failures could be caused by the first recorded failure.

Performing soak tests

At the end of each test, you should carry out a soak test. To do this, leave the unit under test powered up for eight hours, or alternatively, overnight. After carrying out the soak test, it is advisable to retest the unit.

Repairing faults

When repairing a computer, you should repair the faults in the order in which they occurred during the test (ie repair the first recorded failure FIRST).

For further information on checking for component level faults on the main PCB and carrying out repairs, refer to *Part 5 - Main PCB fault diagnosis*.

Creating a test SCSI hard disc

To avoid overwriting the customer's hard disc during testing, prepare a test hard disc as follows:

Equipment required

- SCSI Hard disc to be initialised(UUT)
- A500 series test station (do not use a customer's computer for this test)
- 3.5" Winchester initialiser test disc (0286,822) (write protected)
- Standard RGB colour monitor (Analogue RGB) and cable.

NOTE: The A500 series test station comprises an A500 series computer with the hard disc drive removed and a keyboard attached. Plug the unit under test into the SCSI port of the test station.

Setup procedure

- 1 Connect the test station and the monitor to the mains supply. Do NOT turn on.
- 2 Insert the test disc into the floppy disc drive.

Test procedure

Notes:

- 1 Throughout the test procedure the power shall be the last connection made before a test commences, and the first connection removed when a test is complete.
- 2 The mains supply voltage must be within the rated voltage range as indicated on the PSU input label.
- 3 If a message is expected and has not appeared within 30 seconds record the fault, the machine needs repairing. If a failed message appears, record the fault, and continue the test (as far as possible), then repair.
- 4 If the test equipment fails 3 consecutive UUT's for the same fault it shall be subject to a validation test using a known good UUT and repaired as necessary before testing continues.

Power-up procedure

- 1 Insert the UUT into the test station, taking care to plug the two cables in correctly. Replace the A500's top cover.
- 2 Turn on the monitor.
- 3 Turn on the test station whilst holding down the Delete key (until the appearance of a red border area on the screen).
The test station should display the desktop.
- 4 Press the Break key whilst holding down the Shift key, and then release the Shift key.

The screen should now display the following:

```
SCSI Initialiser V x.xx PRO 0
```

Device identifies itself as a

- 5 The hard disc manufacturer's name, model number, and firmware version number will then be displayed.

- 6 You will then get the following prompt:

```
Do you want to format device 0?
```

- 7 Type Y. This will destroy all data on the hard disc while formatting it. The UUT will then be formatted, a disc shape check performed, verified and sectioned.

- 8 A test is then performed to check the formatted capacity against the expected capacity. The disc capacity check verifies that the capacity is within 10% of the expected capacity.

If the UUT passes all these tests the PASSED message will be displayed prior to the TEST COMPLETE message.

A successful test display should look something like the following:

```
SCSI Initialiser V x.xx PRO 0
Device identifies itself as a Connor
CP3100-100mb-3.50A15
```

W A R N I N G

Formatting will destroy all data on this device

```
Do you want to format drive 0? YES
Formatting Complete
```

```
Reading new disc shape....done
```

```
Verifyied O.K.
```

```
Writing RISC OS partition....done
```

```
Formatted Capacity is 104Mbytes
```

```
Drive Size Passed
```

```
TEST COMPLETE
```

Switch off the test station.

After the test

- 1 Turn all the mains supplies to the equipment off.
- 2 Disconnect the UUT, from all associated equipment, in reverse order to that detailed earlier in the Power up procedure section.

If any fail messages have occurred, the UUT must be sent for repair and retested.

The hard disc is now ready to be inserted in the customer's computer for testing of the computer system.

Maintenance

Inspect and replace all mechanical parts whenever necessary.

Preparing to run the tests

The start-up menus are used to select a test data file. These test data files contain strings that represent tests that can be performed on a system. When you select a data file, the strings are interpreted, and the CMOS RAM is set up to contain this test information. Each test program then reads the CMOS RAM to determine the test type and which of its tests are to be executed. The test program then writes its results to the CMOS RAM. At the end of the test sequence, a program (*reports*) will read the CMOS RAM and display the test results.

You need to save the contents of the CMOS RAM before any of the tests you run, and restore them when the last test is over:

- 1 Insert the dealer test disc (0286,832) into the floppy disc drive.
- 2 Hold down the Shift key and switch the computer on (do NOT touch the Delete key). Keep the Shift key held down while the computer powers up.

The following menu will be displayed:

```
Menu Vx.xx UN-DEF
```

- (A) Test Suite
- (B) Individual Tests
- (C) Load / Save CMOS
- (D) Quit

Select the test type of your choice

- 3 Select option (C) Load / Save CMOS by pressing the C key.
- 4 The Load / Save CMOS selection will be confirmed and then the screen will display the following menu:

```
LOAD / SAVE CMOS RAM V x.xx UN-DEF
```

- 1. Save CMOS RAM to disc.
- 2. Load CMOS RAM from disc.
- 3. Exit Program.

Please select the required option ?

- 5 Select option 1, and then replace the test floppy disc with the data disc.
- 6 When prompted, enter the filename (including the full directory path if necessary) that you want the CMOS RAM saved to.
- 7 Remove the data disc and put it in a safe place.
- 8 Press the space bar to continue.
- 9 Type 3 to exit the program.
- 10 Switch off the computer (leave the monitor on).
- 11 Insert the test disc (0286,832) into the floppy disc drive.
- 12 Switch on the computer, whilst holding down the Delete key (NOT the backspace key), the Shift key and the * key on the numeric keypad. Keep holding down these keys for several seconds, until a momentary red border around the screen confirms that a power-on Delete is taking place. (This action clears the CMOS RAM and resets the configuration defaults to the manufacturer's original specification).
- 13 A boot file will now execute resulting in the following menu being displayed:

```
Menu Vx.xx UN-DEF
```

- (A) Test Suite
- (B) Individual Tests
- (C) Load / Save CMOS
- (D) Quit

Select the test type of your choice

In order to run any of the tests described later in this chapter, you must first have saved the CMOS RAM settings, as described above.

Creating a CMOS test data file

Before you run the tests described later in the chapter, you may need to create a CMOS test data file. This is used in the CMOS RAM test (see the section entitled *Battery backed RAM* on page 4-8).

To do this, proceed as follows:

- 1 Follow steps 10, 11, 12 and 13 in the previous section entitled *Preparing to run the tests*.
- 2 Select the Load / Save CMOS option from the menu.
- 3 Select the Save CMOS to disc option.
- 4 When prompted, enter the path and file name where you want the default CMOS RAM settings saved.
- 5 Store this test data file on a separate disc (the CMOS RAM test data disc).

You have now created a new CMOS RAM test data file.

Completing the tests

When you have finished testing, you need to restore the customer's original CMOS RAM settings:

- 1 Press the Shift and Break keys simultaneously. This will produce the top level menu:

```
Menu Vx.xx UN-DEF
```

- (A) Test Suite
- (B) Individual Tests
- (C) Load / Save CMOS
- (D) Quit

Select the test type of your choice

- 2 Select option (C) Load / Save CMOS. This will produce the following menu:

```
LOAD / SAVE CMOS RAM V x.xx UN-DEF
```

- 1. Save CMOS RAM to disc.
- 2. Load CMOS RAM from disc.
- 3. Exit Program.

Please select the required option ?

- 3 Select option 2, and then replace the test disc with the data disc.
- 4 When prompted, enter the filename (including the full directory path if necessary) that contains the customer's CMOS RAM configuration settings. Press Return.
- 5 Remove the data disc when prompted.
- 6 Press the space bar to continue.
- 7 Type 3 to exit the program.
- 8 Switch off the power to the computer (at the mains switch on the rear of the machine).

Break and Escape key stuck sub-test

If the Break or Escape keys are stuck down, the following message will be displayed on to the screen:

```
THE ESCAPE OR BREAK KEYS ARE STUCK
DOWN. REPLACE THE KEYBOARD
```

The keyboard is faulty and should be rejected.

If everything is normal and no keys are stuck then nothing is displayed on the screen and the program passes straight on to the next sub-test automatically.

Reset button sub-test

During the tests you will be asked to press the reset button. This will test the operation of the switch. If everything is normal then the program will move to the next sub-test automatically.

Stuck key sub-test

During this test, any keys or mouse buttons which are in a permanently closed position (ie stuck down) are displayed on the screen. The screen display will clear, and the following will be displayed:

```
SOME KEYS ARE STUCK
```

Note the keys that are stuck, reject the keyboard or the mouse.

Press the Break key to continue and wait.

Press the Break key; the program will now exit to the Keyboard/Mouse report screen.

If everything is normal and no keys are stuck, then there will be no screen display from this sub-test and the next sub-test will start automatically.

Keyboard LED sub-test

This test checks that the LEDs on Caps Lock, Scroll Lock and Num Lock are working.

The screen will clear and the following will be displayed:

```
CHECK <caps lock> LED is ON
```

- 1 Check that the caps lock keyboard LED is the only LED on, the other two are extinguished.
- 2 Press the Break key and then check the caps lock is extinguished, hence all keyboard LEDs are off.
- 3 This test is repeated for the remaining two keyboard LEDs, the display giving you suitable prompts. Note any LED failures before continuing on to the next test.

This is a subjective test.

Main keyboard sub-test

The display is cleared and the main keyboard matrix is displayed with the words Main Keyboard Test at the top of the screen.

Press each key in turn, starting at the bottom left (Caps lock) moving across to the bottom right (Ctrl) key, then up a line to the left hand Shift key.

As you move across the keyboard pressing the keys in the correct order, the key that is pressed should disappear from the display. The test continues in this way until all the keys up to the function key F12 have been tested.

If the wrong key is pressed nothing will happen. If two keys (the correct key and one other) are pressed this is highlighted in the same way as in the mouse test. If a key fails to disappear after three attempts, the program will display a failure message at the top of the screen, and then prompt you to press the Break key.

The program will now exit to the Keyboard/ Mouse report screen.

Numeric keypad sub-test

The display is cleared and the cursor and numeric key matrixes are displayed. The two key matrixes are tested separately: first the cursor keys, then the text editing keys, and then the Print, Scroll Lock and Break keys.

Finally the numeric matrix is tested, starting with the 0 key and working along the matrix in the same pattern as before, finishing with the # key.

If you press the wrong key, nothing will happen. If you press, two keys this is highlighted in the same way as in the mouse test. If a key fails to disappear then after three attempts, the program will display a failure message at the top of the screen, and then prompt you to press the Break key.

Press the Break key to continue.

If everything is normal the program will automatically move to the keyboard/mouse report screen display.

Keyboard/mouse report screen

At the end of a successful test the following will be displayed:

```
REPORT SCREEN
DIGIMOUSE SUB TEST - PASSED
RESET BUTTON SUB-TEST - PASSED
KEYS STUCK SUB-TEST - PASSED
KEYBOARD LED SUB-TEST - DONE
MAIN KEYBOARD SUB TEST - PASSED
NUMERIC KEY PAD SUB-TEST - PASSED
THE MOUSE TEST HAS PASSED
THE KEYBOARD TEST HAS PASSED
Press 'A' or 'a' to test another
keyboard or
space bar to continue test suite
software.
```

This indicates the end of the test.

Note: The indication that the keyboard has passed is referring to the non-subjective test elements and should not be interpreted as an overall PASS, since you may wish to fail the UUT on the subjective test element.

Note: During the soak test neither the keyboard nor the mouse tests are executed.

SCSI card test

WARNING: This test will write to the SCSI hard disc. You should fit a test hard disc, or alternatively ensure that the customer is aware that their hard disc will be overwritten, and has given their consent before you start.

The screen will clear and the following will be displayed:

```

SCSI PODULE Vx.xx DEALER

SCSI podule fitted in slot 1
Passed EPROM checksum is 65A8
Passed SRAM (00 to FF)
Passed SRAM (FF to 00)
Passed SBIC register test
Passed Data Transfer test

SCSI podule test passed
PRESS <SPACE BAR> TO CONTINUE
    
```

Press the space bar to continue.

Note: The checksum can vary between releases of the test software, so the value given is an example.

Reports

This test will display a report screen showing the status of the tests.

```

REPORTS Vx.xx DEALER

PASSED Configuration
PASSED Floppy Disc
PASSED Keyboard
PASSED CMOS Ram
PASSED Clock/Calendar
PASSED Mouse
PASSED Parallel Port
PASSED Serial Port
PASSED Sound
PASSED SCSI Podule
PASSED Winchester Disc

TESTS PASSED
PRESS <SPACE BAR> TO CONTINUE
    
```

Additional test executed under Soak conditions

Hard disc exerciser

This program will exercise the hard disc by creating 20 random data files on the disc. It will then perform various operations on these files. A pass completion screen display will be of the following form:

```

SCSI Winchester Exerciser

Operations 2048
Pass      Fail      Pass      Fail
File 1    54          File B    39
File 2    55          File C    19
File 3    33          File D    40
File 4    73          File E    33
File 5     3          File F    43
File 6    64          File 10   25
File 7    60          File 11   24
File 8    44          File 12   38
File 9    22          File 14    9
File A    40          File 15   42

Disc Op. : 0      Commands : 0
    
```

The values given to Disc Op. and Commands are 8 bit patterns decoded to be the following:

```

Disc Op.
Bit 7,6,5 Not used
Bit 4      Read Failure
Bit 3      Write Failure
Bit 2      Failed trying to close file

Commands
Bit 7      Fail try to load dummy file
Bit 6      Compact Failed
Bit 5      Verify Failed
Bit 4      Free Failed
Bit 3      Map Failed
Bit 2      CAT Failed
Bit 1      not used Bit 0 not used
    
```

You have now reached the end of the automatically-run tests in the test suite. If you have finished testing, follow the instructions in the section entitled *Completing the tests* on page 4-6.

Individual tests

You can choose which tests you run from this section – they are not all run automatically in sequence. They are for testing an individual module or expansion card. So you have two options:

- You can run any one of the tests described in the section entitled *Main PCB functional test suite* on page 4-7 by itself.
See that section for a description of each module test.
- You can run any one or more of the individual expansion card tests described in the remainder of this chapter.

Run the relevant expansion card test detailed below; if it fails, substitute a known good expansion card. If the test still fails, substitute a known good backplane. If the test fails again, either replace the main PCB, or repair it. For expansion card details, see the relevant user guide supplied with the card.

Note: Expansion cards were previously known as Podules.

Additional equipment required

Refer to the section entitled *Additional test equipment required when testing expansion cards* on page 4-1. It lists the extra equipment you need for each test.

Preparing to run the individual expansion card tests

The tests alter the contents of the battery backed RAM that holds the computer's configuration data.

- 1 Make sure you have followed the instructions in the section entitled *Preparing to run the tests* on page 4-5.
- 2 Select the Individual tests option.
Another menu is then displayed.
- 3 Select the Exp.-Cards option.
(The other option – Pcb-Module – is for when you want to test just one particular main PCB module at a time.)

You will now see part of a list of test options. To see the rest of the options, press the space bar.

ROM expansion card test

Carry out this test whenever you install, repair or replace a ROM expansion card.

Note: These instructions assume that both the expansion card and the backplane have already been correctly installed.

Connect up the equipment

It is important to connect the equipment to the computer in the correct order:

- Ensure the ROM Expansion card test ROM (0276,230-01) is fitted to socket IC6, and set the following links:
 - LK1-6 to position C
 - LK2-6 to position A.
- Ensure the EPROM FS (0276,221) is fitted to IC socket 1, and set the following links:
 - LK1-1 to position A
 - LK2-1 to position C.
- Connect the keyboard to the front panel connector
- Connect the monochrome monitor to the Mono Video socket, or analogue RGB monitor to the Analogue RGB socket
- Connect the monitor to the mains supply (don't switch on yet)
- Connect the computer to the mains supply (don't switch on yet).

Run the test

- 1 Follow the instructions in the section entitled *Preparing to run the individual expansion card tests* on page 4-15.
- 2 Press the relevant key to select the ROM expansion card test.

The display will then clear and the selection will be displayed.

The test will then run. When the test is finished a message is displayed to tell you whether the ROM expansion card has passed or failed.

You have now completed the ROM expansion card tests. Follow the instructions in the section entitled *Completing the tests* on page 4-6.

Remove the test ROM and reset links LK1-6 and LK2-6.

I/O expansion card test & Midi upgrade test

The I/O expansion card test should be carried out whenever you install, repair or replace an I/O expansion card.

The MIDI Upgrade test should be carried out whenever you install, repair or replace the MIDI Upgrade for the I/O expansion card.

Note: These instructions assume that the I/O expansion card, the MIDI upgrade to the expansion card (if fitted) and the backplane have already been correctly installed.

Connecting up the equipment

It is important to connect the equipment to the computer in the correct order. Connect the

- keyboard to the front panel connector
- hi-res monochrome monitor to the Mono and Sync sockets, or analogue RGB monitor to the Analogue RGB socket
- Port Tester 1MHz Bus socket to the computer's 1MHz Bus socket, using the 34way IDC cable
- Port Tester User Port socket to the User Port socket, using the 20way IDC cable
- Port Tester A/D Port socket to the Analogue Port socket, using the 15way IDC D type cable
- MIDI IN socket to the MIDI OUT socket, using the Econet cable
- monitor to the mains supply (don't switch on yet)
- computer to the mains supply (don't switch on yet).

Run the test

- 1 Follow the instructions in the section entitled *Preparing to run the individual expansion card tests* on page 4-15.
- 2 Select the I/O Exp. Card Test option, or the IO Exp. Card + Midi Test option.

The display will then clear and the selection will be displayed.

The test will then run automatically. When the test is finished, a message is displayed to tell you whether the expansion card has passed or failed.

You have now completed the I/O expansion card or the I/O expansion card + MIDI upgrade tests. Follow the instructions in the section entitled *Completing the tests* on page 4-6.

I/O expansion card test

The I/O expansion card test should be carried out whenever you install, repair or replace an I/O expansion card.

Note: These instructions assume that the I/O expansion card and the backplane have already been correctly installed.

Connect up
See the section *upgrade test*.

Run the test

- 1 Follow the instructions to run the individual tests on page 4-15.
 - 2 Select the I/O Exp. Card Test option, or the IO Exp. Card + Midi Test option.
- The display will then clear and the selection will be displayed. The test will then run automatically. When the test is finished, a message is displayed to tell you whether the expansion card has passed or failed. You have now completed the I/O expansion card or the I/O expansion card + MIDI upgrade tests. Follow the instructions in the section entitled *Completing the tests* on page 4-6.

MIDI expansion card test

The MIDI expansion card test should be carried out whenever you install, repair or replace the MIDI Upgrade for the I/O expansion card.

Set up the MIDI expansion card

For this test to be successful, the following cards MUST be installed:

- The MIDI expansion card in the upper socket
- The known good MIDI expansion card in the lower socket

It will therefore be necessary to install the following cards in the correct order:

Note: Make a note of the order of the cards already fitted to the correct sockets.

Proceed as follows:

- 1 Remove the expansion cards from the sockets.
- 2 Ensure the expansion cards are correctly seated in the sockets.
- 3 Remove any expansion cards from the sockets labeled 'MIDI IN' and 'MIDI OUT'.
- 4 Install the known good MIDI expansion card in the backplane socket labeled 'MIDI IN'.
- 5 Install the MIDI expansion card in the backplane socket labeled 'MIDI OUT'.

Connect up the MIDI expansion card

It is important to connect the equipment to the computer in the correct order. Connect the

- keyboard to the front panel connector
- hi-res monochrome monitor to the Mono and Sync sockets, or analogue RGB monitor to the Analogue RGB socket
- Port Tester 1MHz Bus socket to the computer's 1MHz Bus socket, using the 34way IDC cable
- Port Tester User Port socket to the User Port socket, using the 20way IDC cable
- Port Tester A/D Port socket to the Analogue Port socket, using the 15way IDC D type cable
- MIDI IN socket to the MIDI OUT socket, using the Econet cable
- monitor to the mains supply (don't switch on yet)
- computer to the mains supply (don't switch on yet).

- one end of the Econet cable marked IN to the IN socket of the (uppermost) MIDI expansion card under test
 - the other end of this cable to the OUT1 socket of the (lower) known good MIDI expansion card
 - one end of the Econet cable marked O/P to the IN socket of the (lower) known good MIDI expansion card
 - monitor to the mains supply (don't switch on yet)
 - computer to the mains supply (don't switch on yet).
- Note: At this stage the cable marked O/P is only connected at one end. You will be prompted to connect the other end as necessary.

Run the test

- 1 Follow the instructions in the section entitled *Preparing to run the individual expansion card tests* on page 4-15.
- 2 Press the space bar to see the rest of the menu.
- 3 Select the MIDI Expansion option.
- 4 Once the test program is loaded and the first part of the test has been run, the screen displays the following:

```

MIDI Podule Test Vx.xx DEALER

PASSED                Rom test
PASSED                IN socket test

Set Test Switch to THRU or move cable
PRESS <SPACE BAR> TO CONTINUE

```

Note that during this test you can use a test box to switch leads between sockets. If you're not using a test box, ignore any comments about the test switch.

- 5 Plug the free end of the cable marked O/P into the THRU socket of the (uppermost) MIDI expansion card under test.
- 6 Press the space bar to start the test. A PASSED or FAILED message appears.
- 7 When prompted, move the cable from the THRU socket to the OUT1 socket, then press the space bar. A PASSED or FAILED message again appears.
- 8 When prompted, move the cable from the OUT1 socket to the OUT2 socket, then press the space bar. A PASSED or FAILED message again appears.
- 9 A final message appears telling you whether the MIDI expansion card has passed or failed.

You have now completed the MIDI expansion card test. Follow the instructions in the section entitled *Completing the tests* on page 4-6.

Backplane tests

The backplane should be tested if you suspect it is faulty. Likely symptoms of this are

- all installed expansion cards fail their tests
- expansion cards fail their test only if installed in a specific slot
- a known good expansion card fails a test, but then passes the same test on another computer.

Remove the backplane

You must remove the backplane for testing. Note the following:

- Make a record of the positions of any expansion cards already fitted, so you can replace them in their correct sockets after the test.
- Full instructions for the installation or removal of expansion cards and of the backplane are given in *Part 3 - Disassembly and assembly*.

Proceed as follows:

- 1 Remove the top cover of the computer.
- 2 Ensure that the backplane and its support bar are fitted correctly.
- 3 Ensure that all expansion cards are fitted correctly.
- 4 If no fault was visible, remove all expansion cards from the backplane.
- 5 Remove the backplane from the computer.

Test the backplane

Test the backplane PCB electrically using a suitable continuity/isolation analyser and wire harness to suit.

Note: Due to the presence of an active device no pin on any connector may be subjected to a voltage greater than 300mV with respect to any other pin on any other connector.

Replace the backplane

- 1 Replace the backplane in the computer.
- 2 Replace the expansion cards removed at the start of the test in their original sockets.
- 3 Replace the top cover of the computer, as described in *Part 3 - Disassembly and assembly*.

Ethernet I Expansion Card

The Ethernet I expansion card test should be carried out whenever you install, repair or replace an Ethernet I card.

Note: These instructions assume that both the expansion card and the backplane have been correctly installed (with the Ethernet I expansion card installed in skt 1 podule slot 0). See *Part 3 - Disassembly and assembly*.

Connect up the equipment

It is important to connect the equipment to the computer in the correct order. Connect the

- 1 keyboard to the front panel connector
- 2 monochrome monitor to the Mono Video socket or the analogue RGB monitor to the Analogue RGB socket
- 3 monitor to the mains supply (don't switch on yet)
- 4 computer to the mains supply (don't switch on yet).

Run the test

- 1 Ensure that the Ethernet links are set for Ethernet (towards the front of the unit), with the Ethernet I test feedback lead connected between the Ethernet port and the free side of the Ethernet/Cheapernet links.

2 Follow the instructions in the section entitled *Preparing to run the individual expansion card tests* on page 4-15.

3 Select the Ethernet I option.

The test program is then loaded and executed. This test is only a partial test of the Ethernet card. The partial test tests the RAM, ROM and the transmit and receive circuitry when in loopback mode.

When the test has finished, a board passed/failed message is produced.

Check that all the LEDs on the Ethernet I test feedback lead are lit:

- The single red LED lit proves that 0 & 12 volts are present.
- The 5 green LEDs detect the signal returns are in tact.

If the green LEDs are not lit check that there is continuity along the computers back panel.

You have now completed the Ethernet I expansion card tests. Follow the instructions in the section entitled *Completing the tests* on page 4-6.

Check that all LEDs on the test feedback lead are lit:

- the single red LED lit proves that 0 & 12 volts are present
 - the 5 green LEDs detect the signal returns are in tact.
- If the green LEDs are not lit check that there is continuity along the computers back panel.

You have now completed the Ethernet II expansion card tests. Follow the instructions in the section entitled *Completing the tests* on page 4-6.

Ethernet II Expansion Card

The Ethernet II expansion card test should be carried out whenever you install, repair or replace an Ethernet II card.

Note: These instructions assume that both the expansion card and the backplane have been correctly installed (with the Ethernet II expansion card installed in skt 1 podule slot 0).

Connect up the equipment

It is important to connect the equipment to the computer in the correct order. Connect the

- 1 keyboard to the front panel connector
- 2 monochrome monitor to the Mono Video socket or the analogue RGB monitor to the Analogue RGB socket.
- 3 monitor to the mains supply (don't switch on yet)
- 4 computer to the mains supply (don't switch on yet).

Run the test

- 1 Before running the test ensure that the links on the Ethernet card are set to the Cheapernet position (towards the crystal).

The Ethernet test feedback lead should be connected between the Ethernet socket and the free side of the link positions.

- 2 Follow the instructions in the section entitled *Preparing to run the individual expansion card tests* on page 4-15.

3 Select the Ethernet II option.

The test program is then loaded and executed. This test is only a partial test of the Ethernet card. The partial test tests the RAM, ROM and the transmit and receive circuitry when in loopback mode.

When the test has finished a board passed/ failed message is produced.

Part 5 - Main PCB fault diagnosis

This chapter deals with fault diagnosis and repair of the main PCB at component level.

The larger part of this chapter describes how to use the integral test software which is incorporated in the computer's ROMs, and includes details of the power-on self-test (POST), the fault display and the diagnostic interface.

The remainder of the chapter gives details of how to repair a 'dead' computer (see the section entitled *Repairing a 'dead' computer* on page 5-23).

Test equipment you will need

You will need

- an Acorn Probe test kit (part number 0386,804) which contains the following:
 - display adaptor
 - interface cable
 - interface cable with grabber connectors (for attaching to machines without a diagnostic connector)
 - test disc (for use in a host machine)
 - probe test ROMs (4) (0286,834 to 8286,837)
- host machine fitted with a user port (if you are using the external diagnostic interface)
- frequency counter
- 100 MHz oscilloscope
- DC voltmeter
- earth continuity tester
- serial port loopback plug – see *Appendix C - Serial port loopback plug*
- headphones (32 Ohm impedance)
- chip extraction tools (68/84 pin)
- standard items such as soldering/desoldering workstation, screwdrivers, pliers, etc.

IMPORTANT: Use anti-static precautions (ie antistatic matting and wrist-straps) at all levels of servicing.

Integral test software overview

The integral test software is invoked through the ARM reset vector, and will automatically select a test mode defined by the type of reset conditions and the presence or absence of external diagnostic equipment.

When no external equipment is connected, a standard user start up is performed. The test software will examine a status register in IOC to determine whether the reset was a soft reset or a power-on reset:

- If a soft reset occurred (Reset key operated or re-execution of the reset vector) then no further test operations take place and RISC OS is immediately

started. This ensures that the most common type of reset operation is not delayed by operation of the POST.

- If the reset appeared to have been caused by a power-on operation, a short test sequence (the POST) is started. This is accompanied by changes of the screen colour to indicate test progress. If faults are detected, these are indicated by a blinking LED on the floppy disc drive (if fitted). If no faults are found, this test sequence will last between 2 and 12 seconds (dependant on memory configuration).

You can use three types of test interface to modify this standard operation. These are:

- the test link
 - If you have fitted the test link, the POST will be performed regardless of whether the IOC power-on bit is set. This is useful to force repeated test operations on reset without power cycling, and to force a test sequence if the power-on circuitry is faulty.
- the display adapter
 - If you have fitted the display adapter, the POST sequence is forced and the test execution is accompanied by a series of status messages on the attached display which indicate test progress and results. These results may be used to suggest which areas of the system are malfunctioning, although they will rarely identify an actual faulty component.
- the external diagnostic interface
 - If you are using the external diagnostic interface, the integral test software will perform no further automatic operations, but will await commands from a second (host) computer to perform further tests, enter exercising loops etc. You can request the POST sequence. The status messages that are normally sent to the display adapter will instead appear on the host machine's screen.

Power-on self-test (POST)

Note 1: During the POST, the screen mode is set to suit a simple 15kHz monitor (Monitor 0, Sync 0). This will produce a signal unsuitable for VGA or High Resolution monitors, resulting in an unsynchronised screen display. If a stable display is not shown on a type 0 monitor, this may indicate either a video system fault, or some more fundamental fault which stops the test software itself from running.

Note 2: The various power-on key combinations should be held until the message in stage 5 (or the red screen border resulting from a power-on delete operation) appear – the keys will be ignored if released before the self-test sequence has completed.

The following is a normal POST sequence:

- 1 The screen colour is first set to purple to indicate testing has started. The first part of the test:
 - performs a brief ROM and RAM test
 - initialises the IO controller
 - initialises the Video controller.

This part of the test lasts less than a second and is not easily visible. However, certain system failures may cause the machine to crash or halt during this phase: no further activity will occur and this may be read as a major failure, probably of the IO system.

- 2 The screen colour changes to blue if the simple memory test above is passed, indicating that a more extensive test has started. This phase can take up to 12 seconds on a 16MB machine.
- 3 Tests are now performed on the video and sound controller, VIDC. These are again very brief.

- 4 The screen colour reverts to purple and a test is performed for an ARM 3 processor. This test relies on good RAM, and will not be performed if a failure has already been detected.
- 5 The screen now turns black, with a memory size message displayed, indicating that the self-test is now complete. The system will normally start RISC OS. However, an unexpected failure could leave a purple screen displayed, indicating a major system fault.

If a fault has been detected, RISC OS will not start immediately. Instead, the entire screen will change to red, and the LED on the disc drive will flash. The flashing sequence indicates the fault detected in accordance with the fault codes described in the section entitled *Result reporting* on page 5-9 – an 8 digit hexadecimal number is displayed as 8 groups of 4 flashes, where a long flash indicates binary 1 and a short flash indicates binary 0.

Fig 5-1: The test link

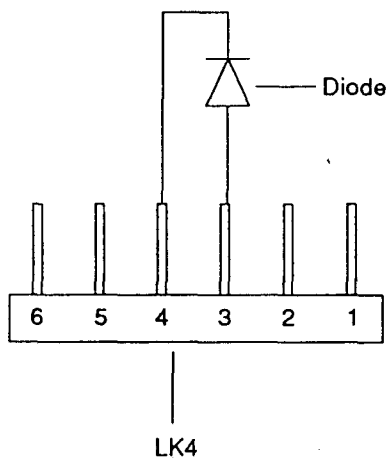
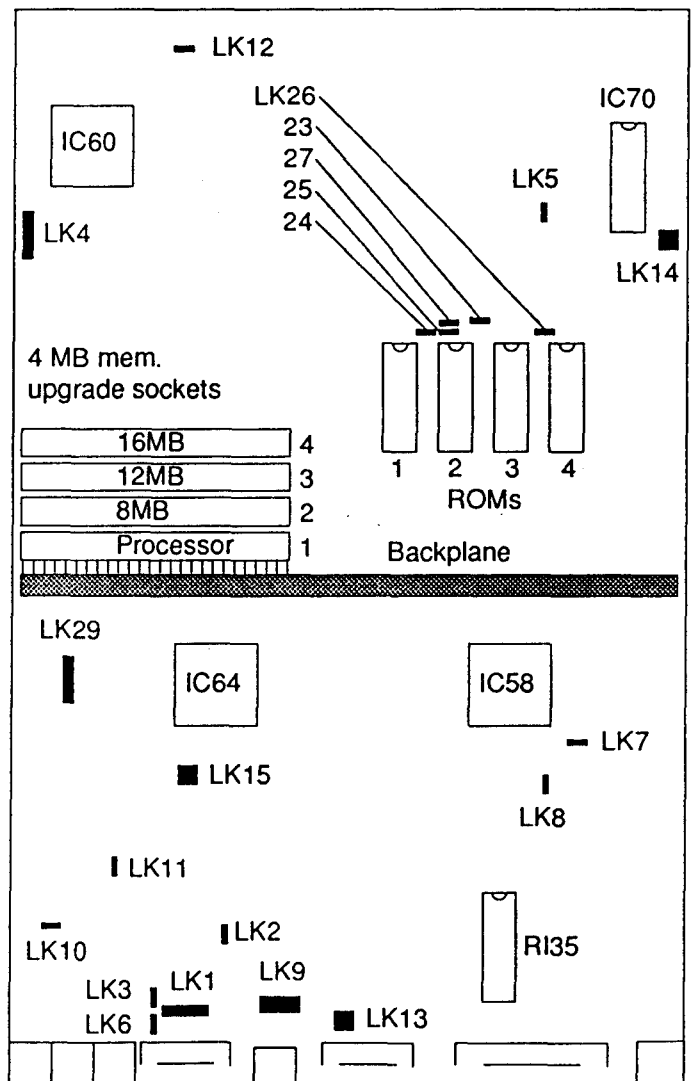

Fig 5-2: Link positions on main PCB



Thus a ROM failure (fault code 00000219 on an ARM 3 machine) will be displayed as:

short short short short	0
short short short short	0
short short short short	0
short short short short	0
short short short short	0
short short long short	2
short short short long	1
long short short long	9

Using the test link

The POST is normally only run after a power-up. If the machine is reset after RISC OS has started, the POST will be skipped. The action taken is dependant on the value of the power-on interrupt bit in IOC.

You can force the self-test to occur (with no IOC read performed) by making and fitting a test link (consisting simply of a diode - IN4148 or similar) to the external test connector. This is shown in *Fig 5-1: The test link*.

The external test connector is the 6 pin link LK4 on the main PCB. It is situated near the four RAM upgrade sockets, as shown in *Fig 5-2: Link positions on main PCB*.

Fitting this link causes the tests to be run regardless of the state of the IOC power-on interrupt bit. This may be useful where it is not convenient to use the full test adapters, and you require some positive indication of a completed test sequence.

If the test link is fitted, the test result code is always displayed (even if no fault is found). You can then read the status bits in the least significant part of the result word: currently, the only useful part of these status bits is to indicate that an ARM 3 has been detected.

The screen will be set to green while the result code is displayed: you can take this as a test pass if it occurs after a proper sequence of purple and blue screens.

Fig 5-3: The display adaptor

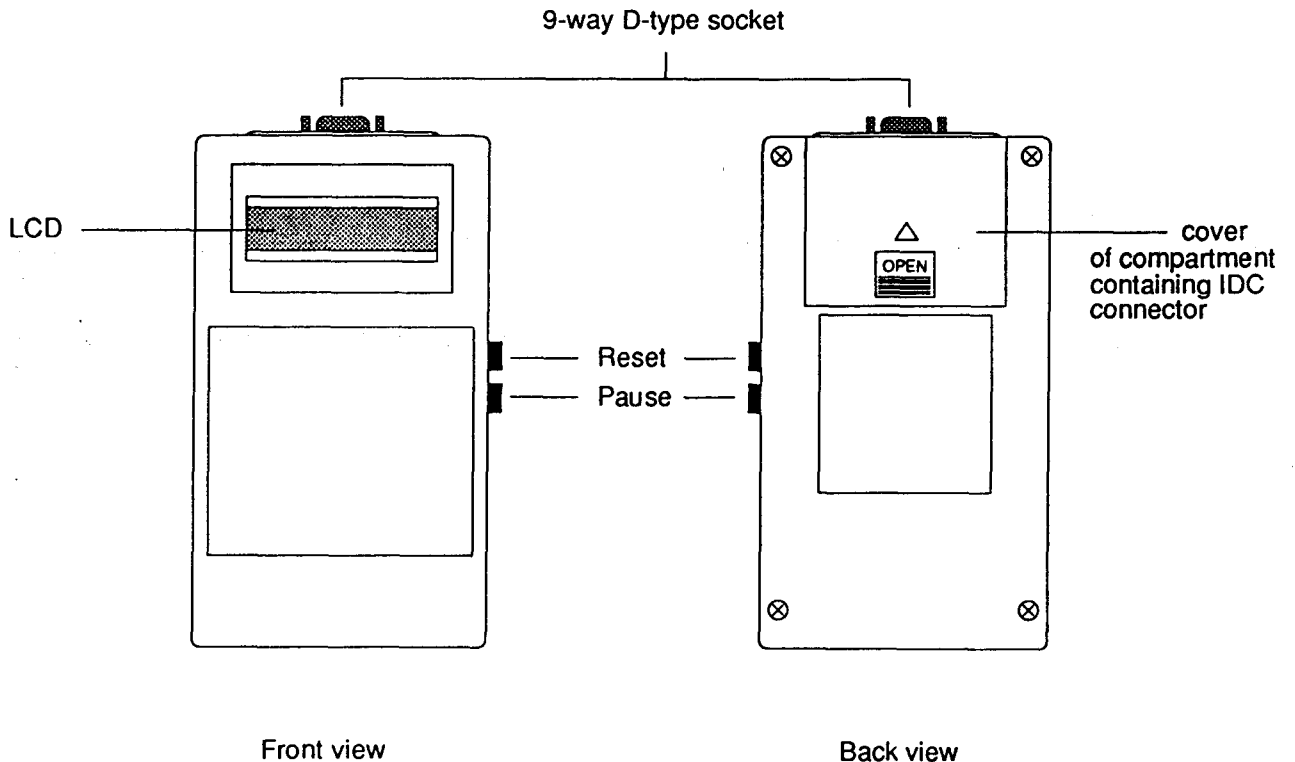

SCSI card test

WARNING: This test will write to the SCSI hard disc. You should fit a test hard disc, or alternatively ensure that the customer is aware that their hard disc will be overwritten, and has given their consent before you start.

The screen will clear and the following will be displayed:

```

SCSI PODULE Vx.xx DEALER

SCSI podule fitted in slot 1
Passed EPROM checksum is 65A8
Passed SRAM (00 to FF)
Passed SRAM (FF to 00)
Passed SBIC register test
Passed Data Transfer test

SCSI podule test passed
PRESS <SPACE BAR> TO CONTINUE
    
```

Press the space bar to continue.

Note: The checksum can vary between releases of the test software, so the value given is an example.

Reports

This test will display a report screen showing the status of the tests.

```

REPORTS Vx.xx DEALER

PASSED Configuration
PASSED Floppy Disc
PASSED Keyboard
PASSED CMOS Ram
PASSED Clock/Calendar
PASSED Mouse
PASSED Parallel Port
PASSED Serial Port
PASSED Sound
PASSED SCSI Podule
PASSED Winchester Disc

TESTS PASSED
PRESS <SPACE BAR> TO CONTINUE
    
```

Additional test executed under Soak conditions

Hard disc exerciser

This program will exercise the hard disc by creating 20 random data files on the disc. It will then perform various operations on these files. A pass completion screen display will be of the following form:

```

SCSI Winchester Exerciser

Operations 2048
Pass Fail Pass Fail
File 1 54 File B 39
File 2 55 File C 19
File 3 33 File D 40
File 4 73 File E 33
File 5 3 File F 43
File 6 64 File 10 25
File 7 60 File 11 24
File 8 44 File 12 38
File 9 22 File 14 9
File A 40 File 15 42

Disc Op. : 0 Commands : 0
    
```

The values given to Disc Op. and Commands are 8 bit patterns decoded to be the following:

```

Disc Op.
Bit 7,6,5 Not used
Bit 4 Read Failure
Bit 3 Write Failure
Bit 2 Failed trying to close file

Commands
Bit 7 Fail try to load dummy file
Bit 6 Compact Failed
Bit 5 Verify Failed
Bit 4 Free Failed
Bit 3 Map Failed
Bit 2 CAT Failed
Bit 1 not used Bit 0 not used
    
```

You have now reached the end of the automatically-run tests in the test suite. If you have finished testing, follow the instructions in the section entitled *Completing the tests* on page 4-6.

Individual tests

You can choose which tests you run from this section – they are not all run automatically in sequence. They are for testing an individual module or expansion card. So you have two options:

- You can run any one of the tests described in the section entitled *Main PCB functional test suite* on page 4-7 by itself.
See that section for a description of each module test.
- You can run any one or more of the individual expansion card tests described in the remainder of this chapter.

Run the relevant expansion card test detailed below; if it fails, substitute a known good expansion card. If the test still fails, substitute a known good backplane. If the test fails again, either replace the main PCB, or repair it. For expansion card details, see the relevant user guide supplied with the card.

Note: Expansion cards were previously known as Podules.

Additional equipment required

Refer to the section entitled *Additional test equipment required when testing expansion cards* on page 4-1. It lists the extra equipment you need for each test.

Preparing to run the individual expansion card tests

The tests alter the contents of the battery backed RAM that holds the computer's configuration data.

- 1 Make sure you have followed the instructions in the section entitled *Preparing to run the tests* on page 4-5.
- 2 Select the Individual tests option.
Another menu is then displayed.
- 3 Select the Exp.-Cards option.

(The other option – Pcb-Module – is for when you want to test just one particular main PCB module at a time.)

You will now see part of a list of test options. To see the rest of the options, press the space bar.

ROM expansion card test

Carry out this test whenever you install, repair or replace a ROM expansion card.

Note: These instructions assume that both the expansion card and the backplane have already been correctly installed.

Connect up the equipment

It is important to connect the equipment to the computer in the correct order:

- Ensure the ROM Expansion card test ROM (0276,230-01) is fitted to socket IC6, and set the following links:
 - LK1-6 to position C
 - LK2-6 to position A.
- Ensure the EPROM FS (0276,221) is fitted to IC socket 1, and set the following links:
 - LK1-1 to position A
 - LK2-1 to position C.
- Connect the keyboard to the front panel connector
- Connect the monochrome monitor to the Mono Video socket, or analogue RGB monitor to the Analogue RGB socket
- Connect the monitor to the mains supply (don't switch on yet)
- Connect the computer to the mains supply (don't switch on yet).

Run the test

- 1 Follow the instructions in the section entitled *Preparing to run the individual expansion card tests* on page 4-15.
- 2 Press the relevant key to select the ROM expansion card test.

The display will then clear and the selection will be displayed.

The test will then run. When the test is finished a message is displayed to tell you whether the ROM expansion card has passed or failed.

You have now completed the ROM expansion card tests. Follow the instructions in the section entitled *Completing the tests* on page 4-6.

Remove the test ROM and reset links LK1-6 and LK2-6.

I/O expansion card test & Midi upgrade test

The I/O expansion card test should be carried out whenever you install, repair or replace an I/O expansion card.

The MIDI Upgrade test should be carried out whenever you install, repair or replace the MIDI Upgrade for the I/O expansion card.

Note: These instructions assume that the I/O expansion card, the MIDI upgrade to the expansion card (if fitted) and the backplane have already been correctly installed.

Connecting up the equipment

It is important to connect the equipment to the computer in the correct order. Connect the

- keyboard to the front panel connector
- hi-res monochrome monitor to the Mono and Sync sockets, or analogue RGB monitor to the Analogue RGB socket
- Port Tester 1MHz Bus socket to the computer's 1MHz Bus socket, using the 34way IDC cable
- Port Tester User Port socket to the User Port socket, using the 20way IDC cable
- Port Tester A/D Port socket to the Analogue Port socket, using the 15way IDC D type cable
- MIDI IN socket to the MIDI OUT socket, using the Econet cable
- monitor to the mains supply (don't switch on yet)
- computer to the mains supply (don't switch on yet).

Run the test

- 1 Follow the instructions in the section entitled *Preparing to run the individual expansion card tests* on page 4-15.
- 2 Select the I/O Exp. Card Test option, or the IO Exp. Card + Midi Test option.

The display will then clear and the selection will be displayed.

The test will then run automatically. When the test is finished, a message is displayed to tell you whether the expansion card has passed or failed.

You have now completed the I/O expansion card or the I/O expansion card + MIDI upgrade tests. Follow the instructions in the section entitled *Completing the tests* on page 4-6.

I/O expansion card test

The I/O expansion card test should be carried out whenever you install, repair or replace an I/O expansion card.

Note: These instructions assume that the I/O expansion card and the backplane have already been correctly installed.

Connect up the equipment

See the section entitled *I/O expansion card test & Midi upgrade test*.

Run the test

- 1 Follow the instructions in the section entitled *Preparing to run the individual expansion card tests* on page 4-15.
- 2 Select the I/O Exp. Card Test option.
The display will clear and the selection will be displayed. The test will then run. When the test is finished a message is displayed to tell you whether the expansion card has passed or failed.
You have now completed the I/O expansion card tests. Follow the instructions in the section entitled *Completing the tests* on page 4-6.

MIDI expansion card test

The MIDI expansion card test should be carried out whenever you install, repair or replace a MIDI expansion card.

Set up the MIDI expansion cards

For this test to function correctly, the MIDI expansion cards **MUST** be installed in these positions:

- The MIDI expansion card under test must be in the upper socket of the backplane, labelled Podule 0.
- The known good MIDI expansion card must be in the lower socket of the backplane, labelled Podule 2.

It will therefore be necessary to rearrange the expansion cards in the computer.

Note: Make a record of the positions of any expansion cards already fitted, so you can replace them in their correct sockets after you have run the test.

Proceed as follows:

- 1 Remove the top cover of the computer.
- 2 Ensure that the backplane and its support bar are fitted correctly.
- 3 Remove any expansion card already in the backplane sockets labelled Podule 0 and Podule 2.
- 4 Install the known good MIDI expansion card in the backplane socket labelled Podule 2.
- 5 Install the MIDI expansion card under test in the backplane socket labelled Podule 0.

Connect up the equipment

It is important to connect the equipment to the computer in the correct order. Connect the

- keyboard to the front panel connector
- hi-res monochrome monitor to the Mono and Sync sockets
or
analogue RGB monitor to the Analogue RGB socket

- one end of the Econet cable marked IN to the IN socket of the (uppermost) MIDI expansion card under test
- the other end of this cable to the OUT1 socket of the (lower) known good MIDI expansion card
- one end of the Econet cable marked O/P to the IN socket of the (lower) known good MIDI expansion card
- monitor to the mains supply (don't switch on yet)
- computer to the mains supply (don't switch on yet).

Note: At this stage the cable marked O/P is only connected at one end. You will be prompted to connect the other end as necessary.

Run the test

- 1 Follow the instructions in the section entitled *Preparing to run the individual expansion card tests* on page 4-15.
- 2 Press the space bar to see the rest of the menu.
- 3 Select the MIDI Expansion option.
- 4 Once the test program is loaded and the first part of the test has been run, the screen displays the following:

```
MIDI Podule Test Vx.xx DEALER
PASSED                      Rom test
PASSED                      IN socket test

Set Test Switch to THRU or move cable
PRESS <SPACE BAR> TO CONTINUE
```

Note that during this test you can use a test box to switch leads between sockets. If you're not using a test box, ignore any comments about the test switch.

- 5 Plug the free end of the cable marked O/P into the THRU socket of the (uppermost) MIDI expansion card under test.
- 6 Press the space bar to start the test. A PASSED or FAILED message appears.
- 7 When prompted, move the cable from the THRU socket to the OUT1 socket, then press the space bar. A PASSED or FAILED message again appears.
- 8 When prompted, move the cable from the OUT1 socket to the OUT2 socket, then press the space bar. A PASSED or FAILED message again appears.
- 9 A final message appears telling you whether the MIDI expansion card has passed or failed.

You have now completed the MIDI expansion card test. Follow the instructions in the section entitled *Completing the tests* on page 4-6.

Backplane tests

The backplane should be tested if you suspect it is faulty. Likely symptoms of this are

- all installed expansion cards fail their tests
- expansion cards fail their test only if installed in a specific slot
- a known good expansion card fails a test, but then passes the same test on another computer.

Remove the backplane

You must remove the backplane for testing. Note the following:

- Make a record of the positions of any expansion cards already fitted, so you can replace them in their correct sockets after the test.
- Full instructions for the installation or removal of expansion cards and of the backplane are given in *Part 3 - Disassembly and assembly*.

Proceed as follows:

- 1 Remove the top cover of the computer.
- 2 Ensure that the backplane and its support bar are fitted correctly.
- 3 Ensure that all expansion cards are fitted correctly.
- 4 If no fault was visible, remove all expansion cards from the backplane.
- 5 Remove the backplane from the computer.

Test the backplane

Test the backplane PCB electrically using a suitable continuity/isolation analyser and wire harness to suit.

Note: Due to the presence of an active device no pin on any connector may be subjected to a voltage greater than 300mV with respect to any other pin on any other connector.

Replace the backplane

- 1 Replace the backplane in the computer.
- 2 Replace the expansion cards removed at the start of the test in their original sockets.
- 3 Replace the top cover of the computer, as described in *Part 3 - Disassembly and assembly*.

Ethernet I Expansion Card

The Ethernet I expansion card test should be carried out whenever you install, repair or replace an Ethernet I card.

Note: These instructions assume that both the expansion card and the backplane have been correctly installed (with the Ethernet I expansion card installed in skt 1 podule slot 0). See *Part 3 - Disassembly and assembly*.

Connect up the equipment

It is important to connect the equipment to the computer in the correct order. Connect the

- 1 keyboard to the front panel connector
- 2 monochrome monitor to the Mono Video socket or the analogue RGB monitor to the Analogue RGB socket
- 3 monitor to the mains supply (don't switch on yet)
- 4 computer to the mains supply (don't switch on yet).

Run the test

- 1 Ensure that the Ethernet links are set for Ethernet (towards the front of the unit), with the Ethernet I test feedback lead connected between the Ethernet port and the free side of the Ethernet/Cheapernet links.

2 Follow the instructions in the section entitled *Preparing to run the individual expansion card tests* on page 4-15.

3 Select the Ethernet I option.

The test program is then loaded and executed. This test is only a partial test of the Ethernet card. The partial test tests the RAM, ROM and the transmit and receive circuitry when in loopback mode.

When the test has finished, a board passed/failed message is produced.

Check that all the LEDs on the Ethernet I test feedback lead are lit:

- The single red LED lit proves that 0 & 12 volts are present.
- The 5 green LEDs detect the signal returns are in tact.

If the green LEDs are not lit check that there is continuity along the computers back panel.

You have now completed the Ethernet I expansion card tests. Follow the instructions in the section entitled *Completing the tests* on page 4-6.

Check that all LEDs on the test feedback lead are lit:

- the single red LED lit proves that 0 & 12 volts are present
- the 5 green LEDs detect the signal returns are in tact.

If the green LEDs are not lit check that there is continuity along the computers back panel.

You have now completed the Ethernet II expansion card tests. Follow the instructions in the section entitled *Completing the tests* on page 4-6.

Ethernet II Expansion Card

The Ethernet II expansion card test should be carried out whenever you install, repair or replace an Ethernet II card.

Note: These instructions assume that both the expansion card and the backplane have been correctly installed (with the Ethernet II expansion card installed in skt 1 podule slot 0).

Connect up the equipment

It is important to connect the equipment to the computer in the correct order. Connect the

- 1 keyboard to the front panel connector
- 2 monochrome monitor to the Mono Video socket or the analogue RGB monitor to the Analogue RGB socket.
- 3 monitor to the mains supply (don't switch on yet)
- 4 computer to the mains supply (don't switch on yet).

Run the test

- 1 Before running the test ensure that the links on the Ethernet card are set to the Cheapernet position (towards the crystal).

The Ethernet test feedback lead should be connected between the Ethernet socket and the free side of the link positions.

- 2 Follow the instructions in the section entitled *Preparing to run the individual expansion card tests* on page 4-15.

3 Select the Ethernet II option.

The test program is then loaded and executed. This test is only a partial test of the Ethernet card. The partial test tests the RAM, ROM and the transmit and receive circuitry when in loopback mode.

When the test has finished a board passed/ failed message is produced.

Part 5 - Main PCB fault diagnosis

This chapter deals with fault diagnosis and repair of the main PCB at component level.

The larger part of this chapter describes how to use the integral test software which is incorporated in the computer's ROMs, and includes details of the power-on self-test (POST), the fault display and the diagnostic interface.

The remainder of the chapter gives details of how to repair a 'dead' computer (see the section entitled *Repairing a 'dead' computer* on page 5-23).

Test equipment you will need

You will need

- an Acorn Probe test kit (part number 0386,804) which contains the following:
 - display adaptor
 - interface cable
 - interface cable with grabber connectors (for attaching to machines without a diagnostic connector)
 - test disc (for use in a host machine)
 - probe test ROMs (4) (0286,834 to 8286,837)
- host machine fitted with a user port (if you are using the external diagnostic interface)
- frequency counter
- 100 MHz oscilloscope
- DC voltmeter
- earth continuity tester
- serial port loopback plug – see *Appendix C - Serial port loopback plug*
- headphones (32 Ohm impedance)
- chip extraction tools (68/84 pin)
- standard items such as soldering/desoldering workstation, screwdrivers, pliers, etc.

IMPORTANT: Use anti-static precautions (ie antistatic matting and wrist-straps) at all levels of servicing.

Integral test software overview

The integral test software is invoked through the ARM reset vector, and will automatically select a test mode defined by the type of reset conditions and the presence or absence of external diagnostic equipment.

When no external equipment is connected, a standard user start up is performed. The test software will examine a status register in IOC to determine whether the reset was a soft reset or a power-on reset:

- If a soft reset occurred (Reset key operated or re-execution of the reset vector) then no further test operations take place and RISC OS is immediately

started. This ensures that the most common type of reset operation is not delayed by operation of the POST.

- If the reset appeared to have been caused by a power-on operation, a short test sequence (the POST) is started. This is accompanied by changes of the screen colour to indicate test progress. If faults are detected, these are indicated by a blinking LED on the floppy disc drive (if fitted). If no faults are found, this test sequence will last between 2 and 12 seconds (dependant on memory configuration).

You can use three types of test interface to modify this standard operation. These are:

- the test link

If you have fitted the test link, the POST will be performed regardless of whether the IOC power-on bit is set. This is useful to force repeated test operations on reset without power cycling, and to force a test sequence if the power-on circuitry is faulty.

- the display adapter

If you have fitted the display adapter, the POST sequence is forced and the test execution is accompanied by a series of status messages on the attached display which indicate test progress and results. These results may be used to suggest which areas of the system are malfunctioning, although they will rarely identify an actual faulty component.

- the external diagnostic interface

If you are using the external diagnostic interface, the integral test software will perform no further automatic operations, but will await commands from a second (host) computer to perform further tests, enter exercising loops etc. You can request the POST sequence. The status messages that are normally sent to the display adapter will instead appear on the host machine's screen.

Power-on self-test (POST)

Note 1: During the POST, the screen mode is set to suit a simple 15kHz monitor (Monitor 0, Sync 0). This will produce a signal unsuitable for VGA or High Resolution monitors, resulting in an unsynchronised screen display. If a stable display is not shown on a type 0 monitor, this may indicate either a video system fault, or some more fundamental fault which stops the test software itself from running.

Note 2: The various power-on key combinations should be held until the message in stage 5 (or the red screen border resulting from a power-on delete operation) appear – the keys will be ignored if released before the self-test sequence has completed.

The following is a normal POST sequence:

- 1 The screen colour is first set to purple to indicate testing has started. The first part of the test:
 - performs a brief ROM and RAM test
 - initialises the IO controller
 - initialises the Video controller.

This part of the test lasts less than a second and is not easily visible. However, certain system failures may cause the machine to crash or halt during this phase: no further activity will occur and this may be read as a major failure, probably of the IO system.
- 2 The screen colour changes to blue if the simple memory test above is passed, indicating that a more extensive test has started. This phase can take up to 12 seconds on a 16MB machine.
- 3 Tests are now performed on the video and sound controller, VIDC. These are again very brief.

- 4 The screen colour reverts to purple and a test is performed for an ARM 3 processor. This test relies on good RAM, and will not be performed if a failure has already been detected.
- 5 The screen now turns black, with a memory size message displayed, indicating that the self-test is now complete. The system will normally start RISC OS. However, an unexpected failure could leave a purple screen displayed, indicating a major system fault.

If a fault has been detected, RISC OS will not start immediately. Instead, the entire screen will change to red, and the LED on the disc drive will flash. The flashing sequence indicates the fault detected in accordance with the fault codes described in the section entitled *Result reporting* on page 5-9 – an 8 digit hexadecimal number is displayed as 8 groups of 4 flashes, where a long flash indicates binary 1 and a short flash indicates binary 0.

Fig 5-1: The test link

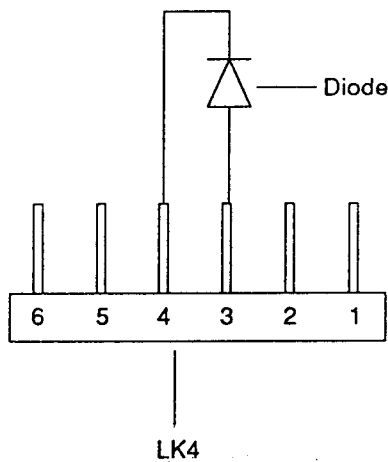
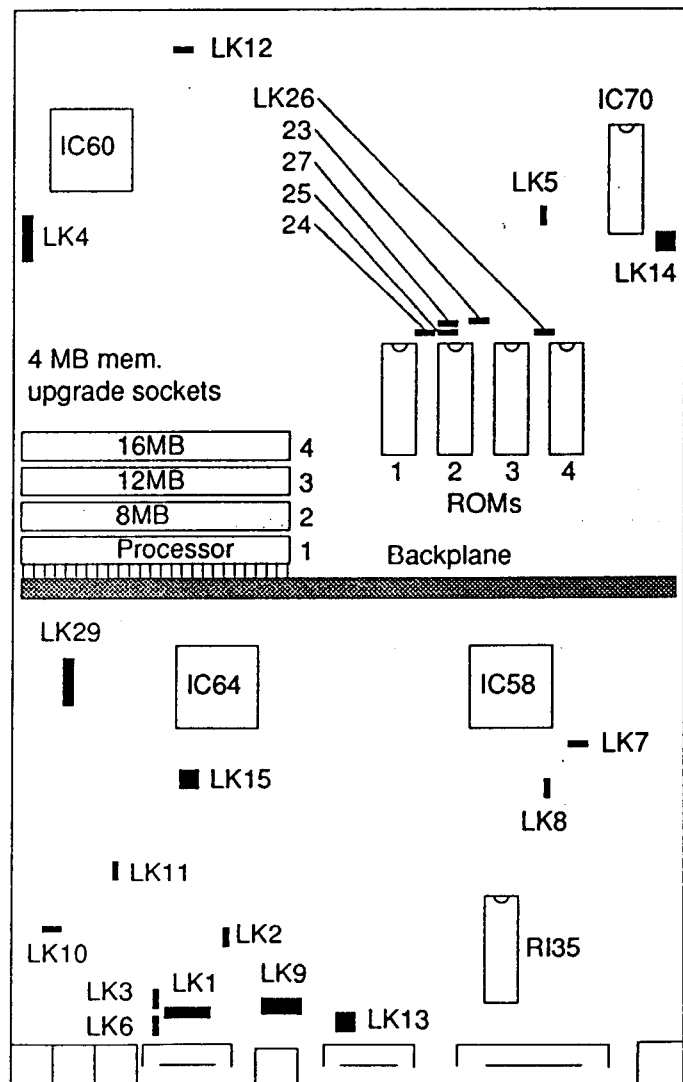

Fig 5-2: Link positions on main PCB



Thus a ROM failure (fault code 00000219 on an ARM 3 machine) will be displayed as:

short short short short	0
short short short short	0
short short short short	0
short short short short	0
short short short short	0
short short long short	2
short short short long	1
long short short long	9

Using the test link

The POST is normally only run after a power-up. If the machine is reset after RISC OS has started, the POST will be skipped. The action taken is dependant on the value of the power-on interrupt bit in IOC.

You can force the self-test to occur (with no IOC read performed) by making and fitting a test link (consisting simply of a diode - IN4148 or similar) to the external test connector. This is shown in Fig 5-1: *The test link*.

The external test connector is the 6 pin link LK4 on the main PCB. It is situated near the four RAM upgrade sockets, as shown in Fig 5-2: *Link positions on main PCB*.

Fitting this link causes the tests to be run regardless of the state of the IOC power-on interrupt bit. This may be useful where it is not convenient to use the full test adapters, and you require some positive indication of a completed test sequence.

If the test link is fitted, the test result code is always displayed (even if no fault is found). You can then read the status bits in the least significant part of the result word: currently, the only useful part of these status bits is to indicate that an ARM 3 has been detected.

The screen will be set to green while the result code is displayed: you can take this as a test pass if it occurs after a proper sequence of purple and blue screens.

Fig 5-3: The display adaptor

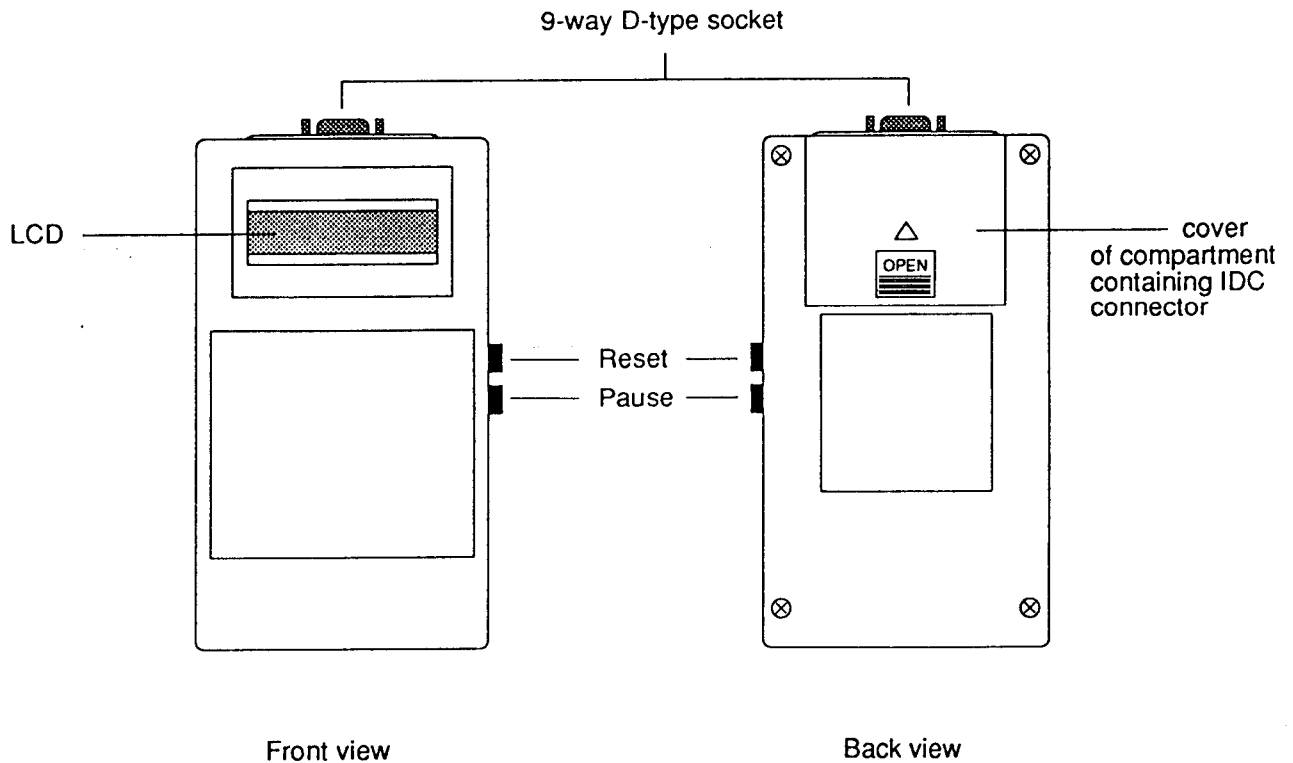

Cycling reset

You can find certain faults (such as address, data bus, or ROM faults) more easily by constantly cycling the reset line to the processor. This causes it to execute the first few instructions in the ROM repetitively. One way to do this is described in the section entitled *Using the external diagnostic interface* on page 5-9. However, you can instead use a fixed-rate oscillator that is built into the reset circuitry. This oscillator will operate if you fit a shorting link to LK5 on the main board, and will permit the processor to run for about 500µS before being reset for about 200µs.

Using the display adapter

The display adapter (Acorn part number 0086,804) consists of a single-line 16 character liquid crystal display with a few support components. See *Fig 5-3: The display adaptor*. The integral test software uses this to display textual progress and status messages. This has the advantage that very little of the target machine's circuitry need be running in order to display these diagnostic messages – this is in contrast to the use of the video display, which requires a great deal of the machine to be working.

The display adapter has the following features:

- Reset button causes the POST sequence to start (you can use this to interrupt a POST that is running, and start again)
- Pause button pressing this suspends the operation of the POST, and allows you time to note down the displayed results of a particular test
- 9-way D-type socket connector for the interface cable
- 20-pin IDC socket used to connect the adapter to the user port on the host machine. You will find this connector, and its cable, in a compartment on the rear of the adapter.

To use the test adapter, proceed as follows:

- 1 Take the top cover off the machine, as described in the section entitled *Removing the top cover* on page 3-1.
- 2 Plug the 9-pin DIN plug on the end of the interface cable into the 9-pin DIN socket on the display adapter.
- 3 Plug the 6-pin connector on the other end of the interface cable onto the external test connector LK4. Note that the brown wire of the interface cable corresponds to pin 1 on LK4.
- 4 Switch on the computer and press the Reset button on the display adaptor to start the POST.

The computer will now cycle through the POST, and you can follow the progress of the test on the LCD. If you need to make a note of any results as the tests are progressing, press the Pause button. This will temporarily suspend the POST, and retain the current message on the display.

If you want to run the POST again, press the Reset button on the adapter.

Each test is preceded by a display of the form

ROM:

where the colon indicates that the test has been started. If the test is passed, no further message relating to that test is displayed. If a test fails, then a message of the form

ROM bad 124AF007

is displayed, where the message indicates the nature of the fault in a context-dependant manner.

Some tests complete by displaying a status message which is neither a pass nor a fail, but for information only (or for the operator to determine the result). These are of the form

M Size 4000.20

where the information is again dependant on the context.

A short delay occurs after every message to give you time to read it: you can extend this by operating the Pause button, which suspends further output until you release it. The test then proceeds normally.

Messages with a numerical content (except for the display of the software release number) are always displayed as one or more hexadecimal fields.

Note that these tests are the same as those performed by the POST. The only difference between the test sequences are that the POST skips the message display when it is found not to exist, and the use of the display adapter avoids the test of an IOC register to determine the necessity for a test sequence. Hence, IOC faults which cause the test sequence to hang in a very early phase are not a problem.

The messages shown on the display adapter are explained below.

Sign on

The first message displayed occurs immediately after the display interface is detected. It consists of a sign-on message indicating the release level of the test software in ROM:

SELFTEST R1.13

After this, VIDC is initialised for a mode 0, sync 0 monitor and the purple screen colour is set, as in the POST.

ROM checksum

The ROM checksum test is preceded by the message

ROM:

and consists of a simple 32-bit wide additive checksum of every word in ROM except the last 2 (ie from &3800000 to &387FFF8 for 1 MBit ROMs). The last two words are

reserved for data used to force the CRC of individual ROMs to be zero. This checksum should always total zero - if it doesn't, the message

```
ROM bad xxxxxxxx
```

(where xxxxxxxx is the calculated checksum in hexadecimal) is displayed. If a faulty checksum is detected, an additional test is performed to search for a possible ROM address line fault. This compares the words at the start of the ROM (&3800000) with data at a series of walking-one addresses (&3804000, &3808000, &3810000 etc). If an image of the initial ROM data is found before the expected end address of the ROM, this may indicate an address line shorted or not connected to the ROM. The results of this test are indicated as

```
ROM size xxxxxx
```

where xxxxxx is the measured size of the ROM in bytes of address space used (080000 for 1Mbit ROMs, 200000 for 4 Mbit ROMs) displayed in hexadecimal.

Memory size determination

The algorithm used by RISC OS to determine memory size and page configuration is also used by the test software. This algorithm will only operate on working memory, since it is not possible to distinguish between faulty memory and not-fitted memory. Use of the same algorithm ensures that memory faults which cause an incorrect determination of memory size to be made will test the memory in the same configuration.

Memory size tests are announced by the message

```
M Size:
```

and the result is indicated by the message

```
M Size  xxxx.yy
```

where xxxx is the measured memory size in KBytes, and yy is the MEMC page size, also in KBytes. Thus a 4MB machine (32K pagesize) should indicate

```
M Size  1000.20
```

Note that complete memory failure will result in selection of the smallest permitted memory configuration, 0100.08 (256 Kbyte, 4K page size).

Memory line tests

These tests attempt to exercise address, data and control lines into the memory array. They are performed only on the size of memory indicated in the previous section.

The data line tests are announced by the message

```
Data:
```

and perform walking-one and walking-zero tests of the data lines in attempt to detect stuck-at-one, stuck-at-zero or tied-together lines. The test is repeated at 1 MB intervals to exercise all arrays of memory devices, and consists of a loop which writes

```
&00000001 to memory at offset 0 from the test
address
&FFFFFFFE to memory at offset 4 from the test
address
```

and cycles these patterns through to

```
&80000000 to memory at offset 248 from the test
address
&7FFFFFFF to memory at offset 252 from the test
address.
```

A second loop then validates the patterns, recording as a bit pattern any data bits which failed to hold the proper values. If any bits failed, the memory sizing algorithm is likely to have set the wrong MEMC page size. This can generate misleading faults, since the highest DRAM multiplexed address line (RA9) is not driven. In order to obtain consistent data bit fault diagnosis, the memory configuration is forced to 32K pagesize. This will cause address errors, but if data errors are present the address tests will be meaningless in any case.

A pair of error messages indicating the first address at which failure occurred and a bitmap of all the failing data bits is displayed. The messages

```
Data @ 2000000
Data 00004001
```

would then indicate that bits D0 and D14 showed a fault at the lowest memory address. Note that this is a physical memory address, since all memory tests are performed in the physical address space.

If the data line tests passed an address line test will then be performed, announced by the message

```
Addr:
```

The test consists of a loop which writes unique data patterns to pairs of word addresses at memory locations between the bottom and (previously calculated) top of physical memory. These locations are again chosen by walking a one and a zero leftwards through the address space: thus the test addresses for 1 MB memory will be

```
2000000 write A5A5A5A5 (test endpoints)
20FFFFFFC write A5A5A5A5
2000004 write 00000004 (bit A2)
20FFFFFF8 write FFFFFFFFB
2000008 write 00000008 (bit A3)
20FFFFFF4 write FFFFFFF7
```

... through to ...

```
2080000 write 00080000 (bit A19)
207FFFC write FFF7FFFF
```

The patterns are then checked, and the address bits which appear to have no effect (ie the same data is read regardless of whether the address bit tested is one or zero) are marked in result bitmap. If any such bits are found, the error message

```
Addr  xxxxxxxx
```

will be displayed, where xxxxxx is the resulting fault bitmap (hence an ineffective bit A8 will result in a fault display of 000100).

Note that the memory sizing algorithm uses address aliasing to determine the MEMC page size to be used. This may cause address line faults to result in an incorrect memory size detection rather than an address line error.

The ARM memory interface is capable of both word and byte accesses to memory. These are indistinguishable when data is read (the whole word is read and the unused data discarded), but byte write operations must write only the proper byte without affecting the other bytes in the same word. This is achieved by using four byte CAS strobes to indicate which byte is to be written. All four strobes occur simultaneously for a word write: thus two strobes shorted together will not be detected by the word-access memory tests.

The byte strobe lines test is announced by the message

Byte:

and consists of a test (repeated at 4 MB intervals within the physical memory address space) which, for each of the four bytes in a word:

- writes a pattern (&AABBCCDD) to the test word
- writes the byte number to the test byte (0 to 3)
- reads back and verifies the modified test word.

If this test fails for any byte strobes at each of four possible 4 MB address areas, a failure message of the form

Byte xxxxxxxx

will be displayed, where xxxxxxxx is the address at which failure occurred, and the lowest digit is a bitmap of the failing byte strobes. Thus a failure of the lowest two byte strobes (CAS0, CAS1) at the second 4MB memory region will be indicated by the fault code 2400003.

Finally, if the line tests all pass and there is less than the (maximum) 16 MB of physical memory fitted, the data line test is repeated just above where memory ends. This produces some diagnostic information about data line faults on expansion memory cards, if such faults have resulted in a failure of the memory-sizing algorithm to detect the presence of the expansion card.

This test is announced by the message

Exp?:

and always results in the two displays which indicate where the memory was tested (this should be just above the reported memory size) and a bitmap of faulty lines

Exp? @ xxxxxxxx Exp? yyyyyyyy

Note that some systems have high-order memory address lines undecoded. This will result in an image of good memory 4 MB above the start of real physical memory. This will have no failing bits, so an expansion bitmap of 00000000 is displayed rather than the expected FFFFFFFF.

IOC test

The functions of IOC are not tested in the current release of the integral test software. However, this stage indicates the first access to IOC and hence if the announcement message

IOC:

remains stuck on the display, an IOC addressing problem is likely to exist. The test does read the IOC interrupt status registers and display them on the LCD: this may be used to indicate, for instance, a stuck FIQ line causing permanent FIQs. No attempt is made to clear pending IOC interrupts before displaying the status registers.

The status registers are displayed in the form

IOC ccaabfff

where cc is the control register, aa is IRQ status register A, bb is IRQ status register B and ff is the FIQ status register. The detailed content of these registers is described in the VL86C010 RISC family data manual.

IO Initialisation

There are a number of IO registers on Archimedes main boards in IOC address space. These are initialized to fixed values to ensure that floppy disc drives, etc are disabled during the POST.

Register initialization is performed after the announcement

IOinit:

is displayed. At the current time, the registers are written as follows:

Address	Data	Register usage
&3350010	&00	Printer port data
&3350018	&00	FDC control & printer strobes
&3350040	&FF	FDD select lines
&3350048	&00	VIDC clock speed selection

Speed test

MEMC has certain configuration possibilities for various ROM speeds. In order to obtain maximum speed from the system, the system memory clock speed is measured and the ROM speed set to ensure the shortest allowed cycle time. Timing the memory speed is dependant on proper operation of IOC and a failure will result in a wildly inaccurate estimate of the system speed. The result of this timing test is therefore displayed for comparison with known standards for given machine types.

The test is announced by the message

Speed:

and the results are displayed in the format

Speed xxxx.y.z

where

- xxxx is the processor speed (in KHz)
- y is 0 for MEMC, 1 for MEMC1a
- z is the chosen EPROM speed as written to the MEMC control register.

These values will vary between machine types, and the bus cycle speed will improve when MEMC1a is fitted. Note that ARM3 uses an additional clock for cached and internal operations which is not enabled when this test is performed.

Large memory test

The earlier memory tests performed brief checks on the memory control and data lines to ensure that the memory components were present and to assist in finding short or open circuits in the interconnections. Ideally, a large number of pattern tests should be run to detect possible pattern sensitivity or obscure bit-failure faults. However, these take a considerable time to run and are not suitable for a POST.

The minimum test required is to exercise each RAM location through zero and one values. The large RAM test does this, using an odd-repeat-length data pattern to reduce the possibility that an address/data line short will be concealed by the test method.

The test code is loaded into RAM for greater speed. For this reason, the test is not run if a previous test has detected any fault, since the test code might not then remain valid for the execution of the test. It is still possible that an addressing fault undetected by the address line tests could cause the test code to be overwritten by the memory test patterns. In this case, the RAM test announcement

RAM:

would remain on the display without a subsequent message. If the RAM test is not run due to previously detected faults, the message

RAM: skipped

will be displayed.

The screen colour changes from purple to blue after the RAM: message is displayed and before the test commences.

If the test fails, the failing location is displayed in a message of the form

RAM Bad xxxxxxxx

where xxxxxxxx is near the failed location. In the current version of the software, the value displayed may be up to 13 words PAST the actual location.

CAM test

The content-addressable-memory used by MEMC to perform logical to physical address mapping is tested by this sequence. The test, announced by the message

CAMs:

relies on proper functioning of some memory in order to store an exception vector. This test is, therefore, not run unless both the memory control lines and the main memory test have passed. In this case, the message

CAMs skipped

will be displayed.

Any failure reported by this test (provided that the memory configuration has been correctly determined: check the result of the 'M Size' test) probably points to a failure in MEMC, although a poor connection to MEMC from the ARM is also possible.

First, the memory is initialised by writing a copy of the vectors and a unique identifying value to each physical page (in descending memory address order). The extent and size of physical pages is determined by the memory sizing algorithm executed earlier. The highest expected page is then checked to ensure it hasn't been overwritten by an address fault when a lower addressed page was initialized. This check is made at descending addresses until a correct identifier is found: this is the highest valid physical memory page and is compared against the expected number of pages for this memory configuration. This part of the test may result in an error message of the form

CAM ## xxx.yyy

meaning that an unexpected number of CAM entries were found, where xxx is the number expected for the calculated memory configuration, and yyy is the number actually found.

The vector in the current page 0 is then checked to ensure it's still there (in physical memory). The test will crash if memory is unable to record the vector. Use of the vector also depends on the proper mapping of logical page zero to a physical page containing the vectors: this cannot be checked, since any attempt to test logical page zero will be forced to use the vector if the memory mapping has failed, crashing the system.

Failure of the vector data to be retained in physical memory is indicated by the message

CAM vec xxxxxxxx

where xxxxxxxx is a bitmap indicating which of the data bits appear to have been lost (1 in a given position indicates that bit failed to retain the expected data).

Each physical page is then mapped at a series of logical addresses. To save time, not all logical addresses are checked – only a short sequence intended to exercise all the comparators in the CAM array with each bit value.

Mapping is checked by placing the physical page at each logical address in turn and checking the expected data at that logical page. It is possible for no page to be mapped there (causing an abort error), for the wrong page to be mapped there (causing a data mismatch) and for the page under test to be simultaneously mapped elsewhere. This last possibility cannot be exhaustively tested in a short time, so again a test is made with each of the bits in the logical page number flipped in turn to test for an address comparator that always finds a match.

The failures indicated by these tests will almost always imply a faulty MEMC: the physical page number in the displayed results may be used to indicate which MEMC in a multiple-MEMC system is at fault. The physical page number (in hexadecimal) should be divided by &80 to indicate the faulty MEMC.

- CAM map xxx.yyyy** The identifier at physical page xxx was not equal to that at logical page yyyy when they should be mapped together.
- CAM pmk xxx.yyyy** The data found at logical page yyyy was the same as that at physical page xxx, but was not the expected value (ie the data had become corrupt)
- CAM als xxx.yyyy** Physical page xxx was mapped at logical page yyyy as well as in it's proper place.
- CAM abo xxx.yyyy** When physical page xxx was mapped at logical page yyyy, MEMC failed to map anything at that logical page at all, so a data transfer abort occurred.

In addition to these reported errors, unexpected processor traps may occur – either the wrong trap when a data abort was expected, or a trap occurring at an unexpected time. These are indicated by one of the following messages:

- RST @ xxxxxxxx Reset
- UDF @ xxxxxxxx Undefined instruction
- SWI @ xxxxxxxx Software interrupt
- PAB @ xxxxxxxx Instruction fetch abort
- DAB @ xxxxxxxx Data transfer abort
- ADX @ xxxxxxxx Address exception
- IRQ @ xxxxxxxx Interrupt
- FIQ @ xxxxxxxx Fast Interrupt

with xxxxxxxx indicating the address at which the trap occurred.

These are extremely unlikely to occur, and although they may be caused by a processor fault are most likely to be due to an earlier failure (eg a RAM failure causing a misread data abort vector) causing the processor to execute code from arbitrary addresses, with unpredictable results.

PPL test

This is an additional MEMC test which exercises the memory protection features. Like the CAM test, it relies on page zero memory to store vectors. It is announced as

PPLs:

which may be displayed as

PPLs: skipped

if previous RAM tests failed.

The test sets the various page protection levels (0 to 3) and performs reads and writes with MEMC in both Supervisor and user mode. All code actually executes in ARM mode 0 (Supervisor), using the Translate flag to indicate to MEMC that user mode access is required. Operating system mode is not currently tested.

Faults may be displayed using a message of the form

PPL bad x.y.zzzz

where x is the page protection level tested (0 to 3), zzzz is the physical page tested and y is the protection found to be present displayed as a bitmap:

- 1000 user mode read permitted
- 0100 user mode write permitted
- 0010 supervisor mode read permitted
- 0001 supervisor mode write permitted

The unexpected trap messages indicated in the previous (CAM test) section may also appear.

VIDC test

It is not possible to monitor the video or sound outputs of VIDC from within the integral test software. However, some timing tests are performed on VIDC to check the proper clock speed (relative to the IOC clock) and to check the basic operation of the timing generators.

The VIDC tests are announced by the message

VIDC:

The vertical timing interval (should be 20mS) is then compared with the IOC timer by examining the IOC timer at two consecutive Virq (VIDC interrupt request) edges. If the timed value is outside 19.8 - 20.2 ms, a failure will be indicated with the message

Virq bad xxxxxxx

where xxxxxxx may be

- 000001 Failed to find the first Virq, to start timing
- 000000 Failed to find second Virq within IOC timeout or either Virq or IOC timeout within 200ms.
- other Measured time in microseconds

Failures may be indicated due to either IOC or VIDC failure or a failure of the Virq interrupt line. An IOC failure will usually also result in an unusual value of the measured processor speed.

Similar tests are performed on the sound section of VIDC: here the IOC timers are set to 10.14 and 10.34 ms. A sound DMA is then started, with a clock rate and length which result in completion in 10.24 ms. The Sirq bit in IOC is tested to ensure that it appears after the expiry of the first timer and before the expiry of the second.

Failures are indicated by the message

Sirq bad xxxxxxx

where xxxxxx may be

- 000001 Timers stuck as though T0 done, T1 not done.

000000	Timers failed to get to T0 done, T1 not done. Either indicate IOC cannot time properly
other	Number of wait loops expired before failure.

Since in this test the clock signals for IOC and VIDC are both derived from the same clock (see *Fig 1-2: System timing* on page 1-2) errors in the speed of this clock will result in the ratio remaining correct. A fault will not be indicated, but the measured processor speed may be abnormal.

The screen colour is restored to purple at the end of this test.

ARM type test

The final test attempts to read the ARM 3 identification register. If an ARM 2 is fitted, an undefined instruction trap should be taken. This test will not be performed if memory is faulty, since it relies on the operation of memory for vector storage.

The test is announced with the message

ARM ID:

or

ARM ID: skipped

and the results are indicated with a message of the form

ARM ID xxxxxxxx

where xxxxxxxx may be

00000000	ARM 2 fitted
41560300	ARM 3.0 ID register content
FFFFFFFF	Fault: exception not taken, no ID read.

Result reporting

At the close of the test sequence, the screen colour is set to red if a failure has been recorded in the tests, green if not. The test result is transmitted to the operator by flashing the disc selection light in accordance with the scheme described earlier.

An overall PASS/FAIL message is also displayed with the same result code - this will be either

PASS: xxxxxxxx

or

FAIL: xxxxxxxx

where xxxxxxxx is a bitmap summarising the test results and other flags. The meaning assigned to these bits is as follows:

Status bits

00000001	Self-test due to power-on
00000002	Self-test due to interface hardware
00000004	Self-test due to test link
00000008	Long memory test performed
00000010	ARM 3 fitted

Fault bits

00000200	ROM failed checksum test
00000400	MEMC CAM mapping failed
00000800	MEMC protection failed
00004000	VIDC (Virq interrupt) timing failed
00008000	Sound (Sirq interrupt) timing failed
00020000	Ram control line failure
00040000	Long RAM test failure

Only bits 8 to 31 indicate faults: any of the bits 0 to 7 may be set with a green screen and the PASS message displayed. Bit patterns not defined above may be assigned to future versions of the test software.

Using the external diagnostic interface

When this interface is attached, the target machine will accept a small number of commands and associated parameters which you can use to exercise memory and peripherals, examine memory or peripheral registers, or even load test code into the target machine for remote execution.

In order to be able to test the target machine using this interface, you need the following:

- a host computer (ie an Archimedes computer fitted with a standard Acorn User Port podule) that boots up from the floppy disc drive by default. You can configure this with the *Command *Configure drive 0
- a display adaptor (Acorn part number 0086,804)
- a test disc
- an interface cable.

To use the external diagnostic interface, proceed as follows:

- 1 Open the compartment on the rear of the display adaptor to reveal the 20-pin IDC connector and cable.
- 2 Plug the IDC connector into the user port on the host machine.
- 3 Connect the interface cable to the 9-way D-type socket on the display adaptor.
- 4 Connect the other end of the interface cable to the test link LK4 on the target machine
- 5 Place the test disc in the floppy drive on the host machine.
- 6 Switch on the host machine, so that it boots up using the test disc.
- 7 Switch on the target machine.

You are now ready to test the target machine. Software support for the external test interface is currently provided by a RISC OS relocatable module called `Probe`, which provides a set of SWIs corresponding to the low-level interface commands and a set of *Commands modelled on the RISC OS *Debug commands. The following pages contain information on these *Commands.

You can select the standard POST sequence: in fact, the display interface is hard-wired to generate this command then passively display the resulting text output. It is therefore also possible to display the POST results on the host's display.

Note: if you attempt to access logical memory without first setting up MEMC, the target will trap with an exception error, jump to a vector which cannot be set up, and crash. It is safe to access ROM (&3800000 to &3FFFFFF) and physical memory space (&2000000 to &2FFFFFF). You can address IO space with careful reference to the IO address map.

The command syntax has been chosen to reflect the similarity with the commands in the RISC OS *Debug module. This results in rather untypeable commands: the use of command aliases is recommended.

You can use the RISC OS Help command to provide reminders of the Probe *Commands and their syntax.

For a detailed description of how the diagnostic interface works, see the section entitled *Display/debug interface* on page 5-14.

*PMemory

Display values in target system memory

Syntax

```
*PMemory [-BRQ] <addr1>
*PMemory [-BRQ] <addr1> [+|-]<addr2>
*PMemory [-BRQ] <addr1> [+|-]<addr2>
+<addr3>
```

Parameters

B Optionally read and display as bytes
R Read repetitively
Q Suppress output (and speed-up loop)
<addr1> Address for start of display
<addr2> offset from <addr1>
<addr3> offset from <addr1 + addr2>

Use

*PMemory is used to list areas of memory in the target system, with syntax similar to that used by *Memory (PRM IV).

The single-address form displays a 256 byte block of memory starting from <addr1>.

The two-address form displays memory starting at <addr1> and ending at <addr1 + addr2>.

The three-address form displays memory starting at <addr1 offset by addr2> and ending at <addr1 offset by <addr2 + addr3>.

The repetitive functions may be used to exercise the target's bus for hardware debugging - the R command will start a repeated read operation on a given address (single-address command) or range of addresses (multiple address command).

Note that use of the R option alters the default address range of the single-address command from 256 bytes to a single (byte or word) operation and also limits reporting of the data value read to loops on which the value changes.

The Q option suppresses all output to greatly increase the loop iteration rate.

Example

```
*PMemory 3800000
```

Displays the first 256 bytes of the MOS ROM, in worldwide format.

Related commands

*Memory, *PMemoryA

***PMemoryA**

Display and alter target system memory

Syntax

```
*PMemoryA [-B] <addr1> [<data>]
*PMemoryA [-BR] <addr1> <data>
```

Parameters

B Alter memory addressed as bytes
R Perform the write operation repetitively

Use

*PMemoryA displays and modifies the contents of the target system memory, either interactively or using the new value given. This may also be used to program peripheral devices or initialise MEMC.

The interactive mode is entered at the given address if no data is given, and operates with a similar syntax to the *MemoryA (PRM IV) command, as follows.

Return	Go to the next location moving in the current direction
-	Change the current direction to step backwards in memory
+	Change the current direction to step forwards in memory
!	Disable address stepping - always use the same address
<hex digits>	Alter a location and proceed to the next address
=<addr>	Move to a given location
@	Display a 256 byte area of memory starting at the current address
[Make the next address the word just read from memory (pointer indirection)
]	Restore the address used before the most recent [
~<options>	Toggle the R and B options
.	To exit

In non-interactive mode, the given data value may optionally be written repetitively until the Esc key is pressed.

Example

```
PMemoryA -b 2000000 89
```

Writes &89 to the first byte location in physical memory space.

Related commands

*MemoryA, *PMemory, *PLoad

***PLoad**

Load the contents of a file to target memory

Syntax

```
*PLoad [-BF] <filename> <hex load addr>
```

Parameters

<filename>	a valid pathname specifying a file
<hex load addr>	target memory address
B	Load memory address as bytes
F	Load all data to the same address

Use

*PLoad performs in a similar manner to *Load (although the files will rarely be compatible). The file specified is loaded either at the load address for the file or (if specified) at <hex load address>.

If the file is executable, *PGo may be used to begin execution.

Example

```
*PLoad $.mmtsts.basemem 2200000
```

Loads the contents of a file \$.mmtsts.basemem to target memory, 2MB from the start of physical RAM.

Related commands

*PMemoryA, *PGo

***PGo**

Execute code on the target machine

Syntax

```
*PGo      <exec addr>
*PGo -V   <vector number>
```

Parameters

```
<exec addr>   Address to begin execution
<vector number> Index into ROM vector table
```

The following vectors are currently defined:

- 0 Restart the test code at the beginning
- 1 Restart test code, ignoring test adapter
- 2 Restart test code, simulating power-on reset
- 3 Restart test code, expecting display adapter
- 4 Restart test code, simulating test link
- 5 Wait to receive command
- 6 Exit test code as though from soft reset
- 7 Exit test code as though from power-on reset

Note that RISC OS does not currently distinguish between the effects of 6 and 7, and the test code will behave similarly for vectors 1,2,3 and 4.

Use

Used to execute parts of the ROM test code or code loaded onto the target machine with *PLoad. ROM-resident code is normally executed through a vector table providing protection against address changes in later ROM versions.

Example

```
*PGo -v 7
```

Start RISC OS on the target machine.

Related commands

*PLoad

***PReset**

Perform a hardware reset on the target machine

Syntax

```
*PReset
*PReset nn
*Preset -P
```

Parameters

```
P      Hold Reset permanently active
nn     Cycle Reset with reset time nn microseconds
```

Use

Reset the target machine when some operation has caused a crash or hang-up.

Generate cycling reset to make the first few execution cycles visible. If about 25 microseconds of executions is allowed, the first few bus cycles will be clearly visible on an oscilloscope due to the high repetition rate. This may be used to debug a system which crashes before running the test code, by examining the system signals for evidence of shorted address or data lines, missing control signals etc.

Force a permanent Reset condition. This will cause the ARM to generate a constantly-incrementing address, which will therefore cycle round the entire address space of the processor. The resulting patterns may be used to check for address line integrity, address decode operation etc.

The *Reset command with no parameters may be used to stop periodic resets or remove the permanent reset condition. Note that *Reset -p and *Reset nn return to the command prompt after setting the operation up: it is not necessary to Esc from these operations.

Example

```
*PReset 25
```

Generates a square wave on the processor reset line with reset asserted for 25 microseconds and execution enabled for 25 microseconds.

Related Commands

None

***PAddex**

Exercise a specified memory location

Syntax

```
*PAddex [-BM] <addr>
*PAddex [-BM] <addr> <addr>
*PAddex [-BCM] -W <addr> <addr> <data>
*PAddex [-BM] -W <addr> <addr> <data>
<data>
```

Use

This command is intended to generate various cycling patterns to assist in debugging address decodes, memory failures etc.

The single-address form generates repeated reads of memory at the given location. If the M option is given, the LDMIA instruction is used to read two consecutive word locations. If the B option is given, byte reads are performed. If two addresses are given, pairs of read cycles alternating between the two addresses are performed.

The W option causes data to be written to the location before reading back: the data written to the address or pair of addresses will be <data> unless the C option is used to write <data> and its complement or unless a second <data> argument is given. The M option will cause STMIA and LDMIA to be used for the operation.

The repetitive operation may be halted with the Esc key.

Example

```
*PAddex -m 2000000
```

Repetitively read address &2000000 and &2000004 using sequential memory accesses.

Related Commands

*PMemory, *PMemoryA, *PDatex

***PDatex**

Exercise the data bus at a given address

Syntax

```
*PDatex [-BCM]
*PDatex [-BCM] <address>
*PDatex [-BCM] <address> <data>
*PDatex [-BM] <address> <data> <data>
```

Use

This command is very similar to PAddex, and is intended to generate various cycling data values to assist in finding data bus open and short circuits.

The command with no arguments performs repetitive writes (of the value &55555555) and reads at address &200000. The B option causes a byte to be written, the M option uses the STMIA / LDMIA to perform consecutive memory cycles at adjacent addresses and the C option causes alternate true and complemented data to be written.

An address may be given to generate the bus cycles at an alternate address and data arguments may be given to specify the data written there.

The repetitive operation may be halted with the Esc key.

Example

```
*PDatex -b 2400000 32
```

Repetitively write (and read back) the byte value 32 to the lowest address used by a second MEMC in a multiple MEMC system.

Related Commands

*PMemory, *PMemoryA, *PAddex

*PMonitor

Display the text normally written to the LCD.

Syntax

```
*PMonitor
```

Use

This command may be used to simulate a display adapter using the external test interface. If no output appears from the target within a short time, and the target is not ready to receive a command from the test interface, it is reset. If the target is ready to receive a command, it is sent the command normally generated by the display adapter. This should start the self-test.

When the self-test sequence is completed, the target will display the test result on screen and disc LED as described in the display adapter section above. The target will not accept further commands until it is reset.

The Monitor operation will continue indefinitely unless halted with the Esc key.

Example

```
*PMonitor
```

Related commands

```
*PReset
```

Display/debug interface

The display/debug interface connects to machines with an external test connector through a 0.025 in sq 0.1 inch pitch 6-way plug. This has connections as follows:

- | | | |
|---|--------|------------------------------------|
| 1 | +5v | |
| 2 | D<0> | 2K2 pull-up to +5v on interface |
| 3 | LA<21> | Output pulse to interface |
| 4 | ROMCS* | Response connection from interface |
| 5 | RST* | Open-collector drive to Reset |
| 6 | 0v | |

You can use the interface with earlier Archimedes systems by making appropriate temporary connections.

Do this using a 0.025 in sq 0.1 inch pitch 3-way plug to connect +5v, 0v and RST to pins 17, 16 and 15 respectively of the Econet interface connector. Use miniature test clips (E-Z hooks) or an IC clip to pick up ROMCS and D<0> from one of the ROM sites (D<0> need not be used – any data line will do) and LA<21> from the address latches (IC30 pin 19 on an A3000).

300-series and early 400 series machines drive ROMCS directly from a PAL and this signal cannot be safely overdriven. To overcome this, place a 330R resistor in the signal from the PAL, as follows:

- 1 Stack two 20-pin sockets on top of one another, bending pin 18 out so that the connection is not carried right through the stack.
- 2 Solder a 330R resistor in line, so that when the adapter is used to hold the PAL, pin 18 is connected through the resistor rather than directly.
- 3 Remove the PAL from its socket near MEMC, insert the adapter in the PAL socket and fit the PAL in adapter socket.

The display/debug interface is primarily a serial-to-parallel interface with some additional features for synchronization and bidirectional data transfer. A shift register is used to perform the serial to parallel conversion, with a 22V10 PAL to perform control and decoding functions. The serial protocol is encoded using groups of pulses closer together than 4 μ S or spaced apart by more than 16 μ S. Discrimination is performed by a retriggerable monostable with a period near 10 μ S.

The pulses are transmitted by the target using the LA21 address line. This line is a 'don't care' in ROM address space, and accesses to a ROM address with this line asserted will normally return data from an aliased ROM address. The interface may respond to the LA21 pulse by forcing ROMCS inactive for the duration of the data fetch: the integral test software will then read the bus with no ROM driving it, obtaining a result different from that read from the aliased ROM address. A pull-up on one bit of the data bus ensures that the value read when nothing drives the bus is non-zero. The integral test software actually asserts both A22 and A21 for the test operation: this allows for expansion to 4MB of ROM.

A number of pulse sequences are recognised by the interface hardware:

Input

Four pulses are sent: the fourth pulse is repeated until ROMCS is asserted in response. The following eight pulses then clock in eight data bits, most significant bit first. ROMCS asserted (overdriven to disable the ROM) is interpreted as a logical '1'. If pulses continue without a break, they should be interpreted as further polling for input and more data may be transferred without returning to the initial four-pulse start-up.

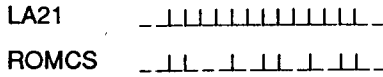

Output

Three pulses are sent: if ROMCS is asserted (overdriven, disabling ROM) in response to the third pulse, the interface is ready for data. A break then occurs, and either another attempt is made or data is sent. Data is transmitted as an eight-group sequence of either one or two pulses, where one pulse is interpreted as a logical '1'. Each sequence of eight bits is preceded by a sequence of three-pulse poll operations to ensure the interface is ready for data. A dummy three-pulse sequence is sent at the end of a series of bytes to ensure that the last byte is recognised.

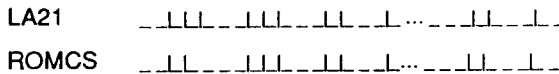

The interface is forced to drive only the LCD module when a pin on the 20-way IDC host connector is NOT grounded. The target will then always read zero from the interface (causing POSTs to execute) and will not write data to the LCD faster than 1 byte / 5ms, to ensure the LCD module always has sufficient time to process commands. The LCD module requires a maximum of 1.6ms to process the slowest command.

The shift register drives the LM020L LCD directly in 4-bit mode to permit control of both data and the RS control line with only 8 bits of I/O. The LCD is never read by the integral test software, even to poll the display's BUSY bit. Instead, another monostable is used to generate the 5ms pause time required to ensure every command has sufficient completion time.

When in host control mode (the connection of the host cable to a user port will short to ground the DEN input) the interface may be controlled by user port bits as follows:

- CB1 (COUT): Host output - clock pulse when writing data to the interface (must be input when PB1 is clock).
- CB2 (WRD): Host output - data from host when writing data to the interface (must be input if MSTR is not asserted).
- PB0 (RDD): Host input - data from interface when reading data.

- PB1 (CIN): Host output - clock pulse when reading data from the interface (must be input if CB1 is clock).
- PB2 (MSTR): Host output - asserted low by the host to obtain control of the shift register.
- PB3 (RDS): Host output - strobed low to indicate data has been read from the interface.
- PB4 (TXRDY): Host input - set high to indicate interface has data ready to send to host.
- PB5 (WRS): Host output - strobed low to indicate data has been written to interface by host.
- PB6 (RXRDY): Host input - set high to indicate interface is read to receive data from host.
- PB7 (RST): Host output - set low to assert RESET on target.

External debug protocol

The integral test software initially performs a four-pulse sequence followed by a gap to ensure the interface state machine is properly reset. A byte '&90' is then transmitted to indicate readiness for a command. This value may change in later issues of the software to indicate changes in the command protocol. The target then waits for a single byte command. The following values are currently acceptable:

- 0 Go to LCD driving mode
- &08 - &0F Write data
- &10 - &17 Read data
- &18 Execute (jump to address)
- &20 - &27 Perform bus cycles
- &FF Perform self test

If the input operation to read this command never sees ROMCS overdriven, no interface hardware is recognised and the IOC power-on-reset bit is tested to determine whether a soft or hard reset sequence should be performed.

Note that the interface hardware in LCD mode will always return 0, causing the POST to be performed. A diode connected between LA21 and ROMCS will appear always to return &FF, forcing a self-test regardless of the state of the IOC power-on reset flag.

In each case (except for Execute), the lower three bits of the command byte provide for options on the command execution.

Write command

Options:

Byte operation	00001XX1
Word operation	00001XX0
Increment address at each operation	00001X1X
Repeat operation at same address	00001X0X
Accept new data for each operation	000011XX
Use same data for each operation	000010XX

Data transfer (all 32-bit words):

- Operation count (bytes or words to write)
- Initial address
- Data
- Additional data if option bit 2 is set
- Checksum fixup

Note that byte data is sent as words, with only the lower 8 bits significant. A fixup value is appended to arrange that the 32-bit additive checksum of the entire command data transfer (ie all except the initial command byte) is zero. If this is not correct, the target will respond with &FF: if it is correct, the target will respond with a copy of the command byte. If more than one word was to be written, it is done at the time of reception: a transfer error will indicate that incorrect data has already been written.

Read Command

Options:

Byte operation	00010XX1
Word operation	00010XX0
Increment address at each operation	00010X1X
Repeat operation at same address	00010X0X
Report every value read	000101XX
Report only last value read	000100XX

Data transfer, host to target (all 32-bit words):

- Operation count (bytes or words to read)
- Initial address
- Checksum fixup

Command acknowledgement:

Target replies with &FF or echo of command byte

Data transfer, target to host (all 32-bit words):

- Data from target to host (one or more words)
- Checksum fixup

Checksums for each transfer block are arranged to be zero, as described in the Write Command, above. Byte data is sent in the lowest 8 bits of a word, one byte per transmitted word.

Execute command

The Execute command has only a single word of data and a checksum. There are no options. The data word is loaded into R15 exactly as transmitted, so take care to ensure that processor and interrupt mode flags are correctly set. The vector execution operations permitted

by the *Go user command are performed by using Read to read the appropriate value from the vector table and Go to start execution.

Bus Exercise command

Although you can use the read and write commands to generate continuous bus cycles with which to exercise particular peripheral and memory locations, it is not possible to produce cycles which toggle address or data bits. The bus exercise command provides a set of small loops which are reproduced below. The code loop executed is defined by the option bits in the command byte. The command is acknowledged (by returning the command byte to the host) before execution starts.

Data transfer (all 32 bit words)

- Operation count (R8)
- First address (R9)
- Second address (R10)
- First data (R11)
- Second data (R13)
- Checksum fixup

Option 000

```
loop LDR r11,[r9] ;read-only separate
      LDR r12,[r10] ;words
      ADDS r8, r8, r7
      BCS loop
```

Option 001

```
loop LDRB r11,[r9] ;read-only separate bytes
      LDRB r12,[r10]
      ADDS r8, r8, r7
      BCS loop
```

Option 010

```
loop STR r11,[r9] ;write and read separate
      STR r12,[r10] ;words
      LDR r1,[r9]
      LDR r2,[r10]
      ADDS r8, r8, r7
      BCS loop
```

Option 011

```
loop STRB r11,[r9] ;write and read separate
      STRB r12,[r10] ;bytes
      LDRB r1,[r9]
      LDRB r2,[r10]
      ADDS r8, r8, r7
      BCS loop
```

Option 100

```
loop LDMIA r9,{r1,r2} ;read-only multiple
      LDMIA r10,{r1,r2} ;words
      ADDS r8, r8, r7
      BCS loop
```

Option 101

```
loop LDMIA r9,{r1,r2} ;read-only multiple
      LDRB r1,[r10] ;words then single bytes
      LDR r1,[r9] ;and single words
      ADDS r8, r8, r7
      BCS loop
```

Option 110

```

loop   STMIA  r9,{r11,r12};write and read multiple
        LDMIA  r9,{r1,r2}  ;words
        STMIA  r10,{r11,r12}
        LDMIA  r10,{r1,r2}
        ADDS   r8, r8, r7
        BCS    loop
    
```

Option 111

```

loop   STMIA  r9,{r11,r12};store multiple words
        STRB   r11,[r10]  ;write byte
        STR    r12,[r9]   ;write words
        LDMIA  r9,{r1,r2}
        LDRB   r1,[r10]
        LDR    r1,[r9]    ;read single and
        ADDS   r8, r8, r7 ;multiple words
        BCS    loop
    
```

Note that R7 holds the value -1, and is used to decrement the loop counter in R8. The pattern of using bit zero to define a word or byte operation is broken on options 101 and 111, since there is no load multiple byte instruction. These options instead contain a mixture of byte, word and multiple word operations. The second address (R10) is used only for byte operations, and so need not be a word-aligned value.

Probe SWIs

The *commands documented above are built around the simple operations described in the debug protocol. The low-level operations used to write commands to the target system are made available by the Probe module as a set of SWIs, described on the following pages.

Probe_Reset

(SWI & C8000)

Reset the target machine

On entry

R0 = Reset repetition period in microseconds
 00000000 for single-shot reset
 FFFFFFFF for permanent reset

On exit

R0 = result status
 0 if the SWI succeeded
 pointer to error block if the SWI failed

Interrupts

Unchanged

Processor mode

SVC mode

Re-entrancy

Not re-entrant (to safeguard hardware state)

Use

This is used to force the target system Reset line active cyclically, permanently or transiently.

Related SWIs

Probe_Write, Probe_Read, Probe_Run

Related vectors

None

Probe_Write

(SWI &C8001)

Write memory locations in the target machine

On entry

R0 = target address
R1 = block size, in bytes
R2 = source address (local machine)
R4 = options

On exit

R0 = result status

Interrupts

Interrupts may be enabled

Processor mode

SVC mode

Re-entrancy

Not re-entrant

Use

May be used to load target memory before a subsequent Probe_Run, for memory verification with a subsequent Probe_Read, for bus exercising or for IO programming.

Related SWIs

Probe_Reset, Probe_Read, Probe_Run

Related vectors

None

Probe_Read

(SWI &C8002)

Read memory locations in the target machine

On entry

R0 = target address
R1 = block size (in bytes)
R2 = destination address (local machine)
R4 = options

On exit

R0 = result status

Interrupts

May be enabled

Processor mode

SVC mode

Re-entrancy

Not re-entrant

Use

To verify memory after a previous Probe_Write operation and for reading peripheral status or ROM content.

Related SWIs

Probe_Reset, Probe_Write, Probe_Run

Related vectors

None

Probe_Run

(SWI &C8003)

Execute code in the target machine

On entry

R0 = target address

On exit

R0 = result status

Interrupts

May be enabled

Processor mode

SVC mode

Re-entrancy

Not re-entrant

Use

To execute built-in ROM self-test function or code previously downloaded using Probe_Write.

Related SWIs

Probe_Reset, Probe_Write, Probe_Read

Related vectors

None

Probe_Busex

(SWI &C8004)

Generate repetitive bus cycles

On entry

R0 = options

R1 = repetition cycles

R2 = first address

R3 = second address

R4 = first data

R5 = second data

On exit

R0 = result status

Interrupts

May be enabled

Processor mode

SVC mode

Re-entrancy

Not re-entrant

Use

To repetitively read and write given locations with given data to assist in hardware debugging.

Related SWIs

Probe_Reset, Probe_Write, Probe_Read

Related vectors

None

Probe_Poll

(SWI &C8005)

Read status of interface hardware

On entry

N/A

On exit

R0 = result status

R1 = interface status

Flags ST_TXRDY (&10) and ST_RXRDY (&40) in R1 indicate data available from the target and target ready to receive data respectively.

Interrupts

May be enabled

Processor mode

SVC mode

Re-entrancy

Not re-entrant

Use

To poll interface hardware and determine readiness to accept or complete commands.

Related SWI

Probe_GetByte, Probe_PutByte, Probe_GetSlow
Probe_GetWord, Probe_PutWord

Related vectors

None

Probe_GetWord

(SWI &C8006)

Read a 32-bit word from the interface hardware

On entry

R0 = target address

On exit

R0 = result status

R1 = word read

Interrupts

May be enabled

Processor mode

SVC mode

Re-entrancy

Not re-entrant

Use

To perform low-level operations required to transfer data for the SWIs &C8000 to &C8004.

Related SWIs

Probe_Poll, Probe_PutWord, Probe_GetWord
Probe_PutByte, Probe_GetByt, Probe_GetSlow

Related vectors

None

Probe_PutWord

(SWI &C8007)

Write a 32-bit word to the interface hardware

On entry

R1 = word to write

On exit

R0 = result status

Interrupts

May be enabled

Processor mode

SVC mode

Re-entrancy

Not re-entrant

Use

To perform low-level operations required to transfer data for the SWIs &C8000 to &C8004.

Related SWIsProbe_Poll, Probe_PutWord, Probe_GetWord
Probe_PutByte, Probe_GetByt, Probe_GetSlow**Related vectors**

None

Probe_GetByte

(SWI &C8008)

Read a 8-bit byte from the interface hardware

On entry

R0 = target address

On exit

R0 = result status

R1 = byte read

Interrupts

May be enabled

Processor mode

SVC mode

Re-entrancy

Not re-entrant

Use

To perform low-level operations required to transfer data for the SWIs &C8000 to &C8004.

Related SWIsProbe_Poll, Probe_PutWord, Probe_GetWord
Probe_PutByte, Probe_GetByte, Probe_GetSlow**Related vectors**

None

Probe_PutByte

(SWI &C8009)

Write a 8-bit byte to the interface hardware

On entry

R1 = byte to write

On exit

R0 = result status

Interrupts

May be enabled

Processor mode

SVC mode

Re-entrancy

Not re-entrant

Use

To perform low-level operations required to transfer data for the SWIs &C8000 to &C8004.

Related SWIs

Probe_Poll, Probe_PutWord, Probe_GetWord
 Probe_PutByte, Probe_GetByt, Probe_GetSlow

Related vectors

None

Probe_GetSlow

(SWI &C800A)

Read a byte slowly from the interface hardware

On entry

R0 = target address

On exit

R0 = result status

R1 = byte read

Interrupts

May be enabled

Processor mode

SVC mode

Re-entrancy

Not re-entrant

Use

To read data normally intended for the LCD module. This SWI is similar to Probe_GetByte, but ensures that the data remains latched on the interface sufficiently long to permit the LCD module to accept the data.

Related SWIs

Probe_Poll, Probe_PutWord, Probe_GetWord
 Probe_PutByte, Probe_GetByte, Probe_GetSlow

Related vectors

None

Repairing a 'dead' computer

See the section entitled *Checking a 'dead' computer* on page 4-2 for initial tests.

These notes are a guide to diagnosing and repairing faults on the main PCB, resulting from the initial tests.

Video failure

- 1 Check for +5 V on both ends of L1; if open circuit then check C9 for short circuit. Also check for 3.5 Volts (approx.) on IC 54 pin 43. Should this not be present then check R10, D4 and C31.
- 2 Check for a 24 MHz clock on IC54 pin 19. If missing then check continuity to and through LK17 and its shunt.
- 3 Check for video data on IC 54 pins 39, 40 and 41. If not present, check power supply to IC 54; if present, before finally changing IC 54.
- 4 Check for short circuits on signals VIDRQ and VIDAK. Check connection of all data lines to VIDC.

System Failure

In order to eliminate the major devices first, change in turn the ARM processor module, MEMC IC 60, IOC IC 58 and VIDC IC 54. Re-try the system after each device change. If the system still appears to be dead, proceed as follows:

- 1 Check for main system clock of 24 MHz on LK11 centre position. If absent, check again on IC 57 pin 8; if still absent, check for Z 96 MHz (this will look like a sine wave of small amplitude if a high quality oscilloscope is not used), on IC57 Pin 11. Change IC57 if 96 MHz is present. If not, try changing IC51, Q1 and X1.
- 2 Check for clocks on MEMC IC 60 pin 67 and VIDC IC 54 pin 19.
- 3 Check that the signal RST driving MEMC IC 60 pin 44 and IOC IC 58 pin 9 is not stuck high.
- 4 Check for the presence and validity of the processor addresses and $\Phi 1$ clock. This can be done by examining the signals on IC 69 pins 12 to 19, IC 68 pins 12 to 19 and IC 67 pins 12 to 15, whilst holding down the RESET button on the keyboard. In this situation the processor continuously increments its address bus. Should any of the signals not toggle, suspect either a short or open circuit on that line. Should none of the signals toggle, check for the $\Phi 1$ clock on the appropriate IC and on MEMCIC 60 pin 66. Also check to see that addresses are being presented to the inputs of the above devices. Change ICs 67, 68 or 69 as appropriate, or if no addresses are present, change the ARM module.
- 5 The data bus can be inspected by probing on SK5 pins b1 to b32. By their nature, it is difficult to interpret the signals seen, so just check for the ability of the signals

to move between logic states. None of these lines should be stuck permanently high, low or in a midrail state. Also check for short or open circuits on the BDATA bus, IC 9 pins 12 to 19 and IC 58 pins 12 to 19. A fault here may well cause a false interrupt.

- 6 Check for shorts on DRAM address bus, either on the DRAMs themselves or on IC 60 pins 28 to 37.
- 7 Check for Data and Address signals on all four of the ROMs. This is especially important if the ROMs have been disturbed, as mis-use of a screwdriver during ROM removal may have damaged or broken PCB tracks or pins on the socket.
- 8 Check for all address lines on MC, again with RESET held down.
- 9 Check the processor interrupt lines FIQ and IRQ pins 8 and 7 on ARM IC 3. Neither of these should be stuck low. IRQ can be expected to pulse low, FIQ should be high. These interrupts should also be checked at their source on IOC IC 58 pins 50 and 51. Should these also be low, the interrupt source can be traced by examining all interrupt inputs to IOC IC 58 on pins 30 to 42 (note that pins 30, 31 and 42 are active high logic).
- 10 Check corner pins of IOC IC58 for short circuits.
- 11 Check for a RAS signal on pin 9 of all the DRAMs.

Test ROMs

The test ROMs are designed to assist in the repair of all Archimedes systems where 'Failure to Initialise' faults are present - ie the machine appears to be 'dead' on power-up.

Note: This section is included for compatibility - it is recommended that you use the test interface described earlier in this chapter.

The ROMs contain software which can be categorised in two sections:

- 1 Main memory test routines.
- 2 Test routines for use under repetitive reset.

To install the test ROMs, carefully remove the RISC OS ROM set, ICs 47, 48, 49 and 50 and replace them with the test ROMs, 0, 1, 2 and 3 respectively - see the diagram on following page.

Note the correct position of the ROMs in their sockets; ROM pin 1 is two rows down from the 'top' of the socket.

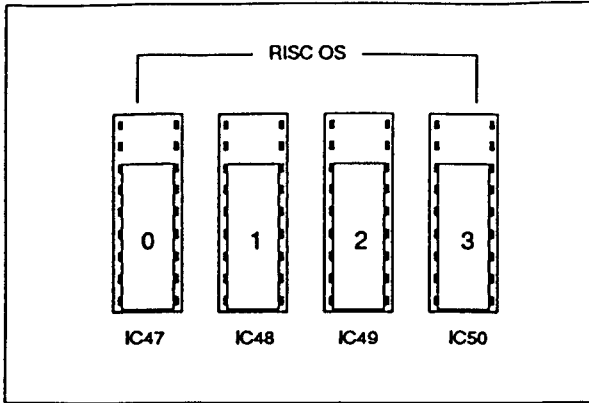

Fitting the test ROMs in place of the RISC OS ROMs

Providing that the ARM, memory controller and video controller are functioning, the test ROMs will auto-boot into the menu-driven display shown in Fig 5-4 Test ROM display menu. At any point in the operation of the test ROMs, pressing the BREAK key or re-powering the machine will re-start the program and re-display the menu.

Main memory test

The memory test checks memory according to memory size selected.

It is possible that faulty memory may lie in the region designated as screen memory. If this occurs, the video display may become unreadable. For this reason, the

Fig 5-4 Test ROM display menu

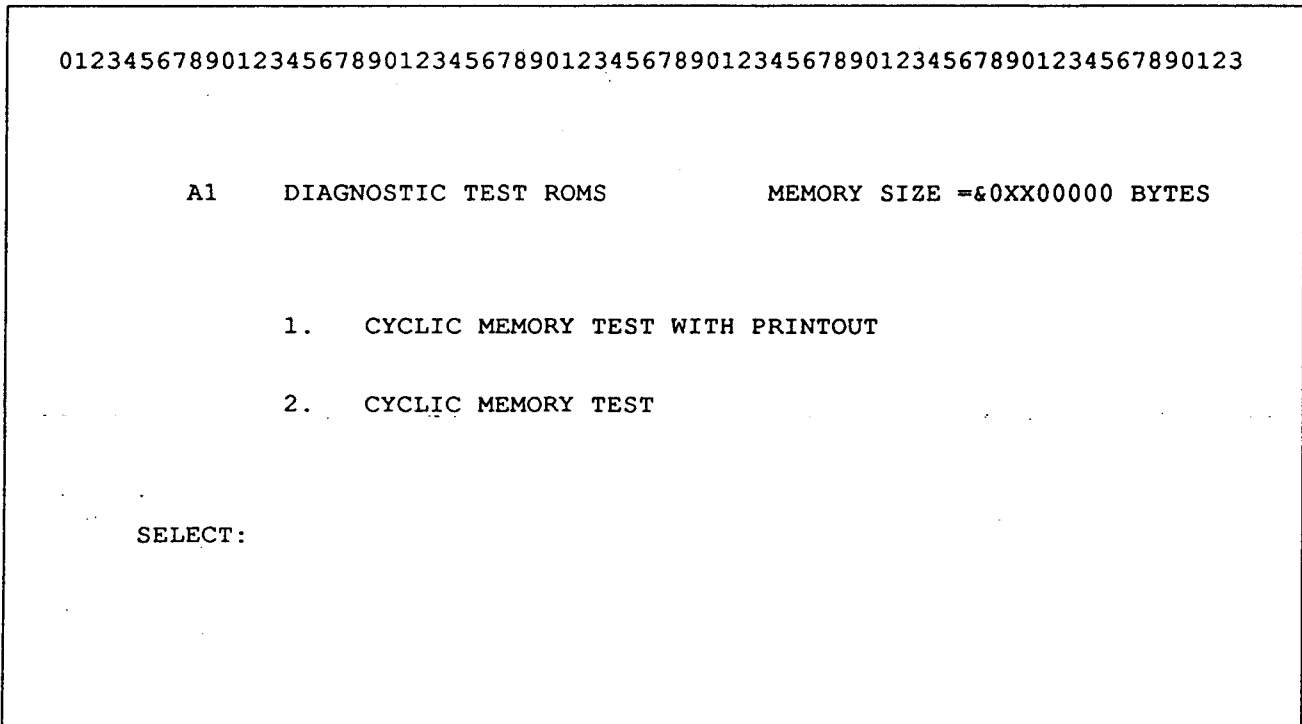

sequence 0123456789 is repeated across the top line of the display. Every 4 digits represents a 32 bit word. Watch for missing or corrupted display.

As the start of the screen memory is known to be at physical address &2000000, it should be possible to determine the exact device that is faulty by examining the corruption pattern on the display.

The default 'memory size' is &100000 bytes (1Mb), however this may be cycled through 0.5, 1, 2 and 4Mb memory sizes by pressing the 'M' key.

When using the ROMs on a machine having memory content other than 1Mb, the video display may at first appear out of line or incorrect. In this instance press the 'M' key repeatedly until the required memory size has been selected.

The memory test is cyclic and on completion of each full memory test a full stop ('.') will be displayed. The 4Mb test takes about 29 seconds.

If for some reason the video display is completely blank or unreadable (eg because of a video fault), a printed output may be obtained by selecting option 1, the output being produced at the printer port as well as on the VDU.

If an error is found in the memory, the display will show:

```
AT ADDRESS &nnnnnnnnn WROTE &ppppppppp READ
xxxxxxxxxxxxxxxxxxxxxxxxxxxxxxxxxxxxxxxx
```

where nnnn is the faulty address, pppp is the data written to that address and xxxxxxxx is the data read back from that address in binary form.

The memory tests do not terminate unless an error is found, in which case after reporting 8 or 9 errors, the test will terminate.

An additional check is now made on the state of CMOS RAM control lines C0 and C1. If either of these lines are short-circuit to 0 Volts, the test ROMs will indicate this on power-up.

Repetitive reset test

This section of test code is intended for use when the main memory test menu fails to initialise.

To make use of this section of the ROMs the following test equipment is required:

- Oscilloscope
- Signal or pulse generator

The purpose of the code is to produce certain signals around specific areas of the PCB. These signals may then be monitored using the oscilloscope to assess the operation of that area of the circuit.

The code is written in a loop which should execute three times before proceeding to the main memory test. For this reason the machine must be reset repeatedly.

A suitable square wave or, preferably, a negative-going pulse generator output at 10 KHz should be connected to the reset line via a component connected to IOC IC58 pin 29.

After setting the border colour to white, the signals should be observable in the following order.

SVPMD	low
SVPMD	low
SVPMD	low
IOC CS & S1	hi
IOC CS & S2	hi
IOC CS & S3	hi
IOC CS & S4	hi
IOC CS & S5	hi
IOC CS & S6	hi
IOC CS & S7	hi
nB/W	low
nB/W	low
nB/W	low
IOC CS & C0	hi

Return to start for three executions.

After execution of this code, the border colour is reset to black. The assembler listing for this section of code is shown below:

```

Start1    LDRT    r0,    [r5]    ;SVPMD pin low)
          LDRT    r0,    [r5]    ;
          LDRT    r0,    [r5]    ;
          LDR     r1,    iocmof   ;re-load ioc base addr. -offset
          LDR     r0,    [r1,r6]! ;SVPMD pin high
          LDR     r0,    [r1, r6]! ;IOC CS pin high      ;S1 ioc hi
          LDR     r0,    [r1, r6]! ;IOC CS pin high      ;S2 ioc hi
          LDR     r0,    [r1, r6]! ;IOC CS pin high      ;S3 ioc hi
          LDR     r0,    [r1, r6]! ;IOC CS pin high      ;S4 ioc hi
          LDR     r0,    [r1, r6]! ;IOC CS pin high      ;S5 ioc hi
          LDR     r0,    [r1, r6]! ;IOC CS pin high      ;S6 ioc hi
          LDR     r0,    [r1, r6]! ;IOC CS pin high      ;S7 ioc hi

          LDRB   r0,    [r5]    ;nB/W pin high      )
          LDRB   r0,    [r5]    ;nB/W pin high      )
          LDRB   r0,    [r5]    ;nB/W pin high      )
          MOV    r1,    #&FE0000 ;
          STR    r1,    [r7]    ; set C0            )
          MOV    r1,    #&FD0000 ;
          STR    r1,    [r7]    ; set C1            )
          MOV    r1,    #&FB0000 ;
          STR    r1,    [r7]    ; set C2            )
          MOV    r1,    #&F70000 ;
          STR    r1,    [r7]    ; set C3            ) I.O.C.
          MOV    r1,    #&EF0000 ;
          STR    r1,    [r7]    ; set C4            )
          MOV    r1,    #&DF0000 ;
          STR    r1,    [r7]    ; set C5            )
          MOV    r1,    #&FF0000 ;
          STR    r1,    [r7]    ; reset all

          LDR     r1,    &55555555 ; write to printer port
          STR    r1,[r8] ;

          SUBS   r9, r9, #1
          BNE   start1

          B     main

```

Repairs following functional testing

The following notes refer to the functional test procedures described in the previous chapter, and give component level diagnosis and repair information following a test failure.

Unless otherwise stated, always perform the simple checks given in *Part 4 - Fault diagnosis* first, then refer to the relevant component level information below.

Type/Model

Memory area fault— run the Memory Test (see the section entitled *Test ROMs* on page 5-23) and repair as necessary.

Memory

Repair as above.

Battery-backed RAM

If the NVM suffers data retention problems and the RTC fails, then, with the computer power off, check for about 2.8 V on IC22 pin 8. If this voltage is not present, check the charge state of the battery BT1 (1.2V).

If the NVM IC22 consistently fails on the same data bits, change the device.

If the clock fails to run or runs inaccurately, check and if necessary replace X3. LK8 allows access to the clock signal.

Audio (Loudspeaker test and Headphones test)

Test the audio with both headphones and internal speaker. Do not forget to issue *SPEAKER ON and *VOLUME 127 commands.

If only the speaker fails, check connections to the main PCB via LK13 and check IC80 pin 5 for a signal of 3 V amplitude. If no signal is present on pin 5 but can be found on pin 3, change IC80.

If there is no audio at all, first check for +5 V on both ends of L18. If this is open circuit, check the condition of C2 before replacement. Check for -5 V on IC78 pin 11 and R49 and R43. Check for about 3 V on VIDC IC 54 pin 12.

A low-amplitude signal should be found on VIDC IC 54 pins 13, 14, 15 and 16. If not, change VIDC. These signals can be traced through the peripheral circuitry and out to Q12 and Q13. The signal amplitude at these points should be about 1.5 V peak to peak.

Check for short or open circuit on signals SNDK and SNDRQ on VIDC IC 54 pins 9 and 24.

Monitor Screen

If the display breaks up around its edges and spurious characters appear then investigate the system oscillator. Check IC 51 and X1.

Check DRAM using the test ROMs (see the section entitled *Test ROMs* on page 5-23).

With a full white screen, VIDC IC 54 pins 39, 40 and 41 should all have the same signal on them. If not, change the VIDC IC 54.

Trace each signal through the periphery circuitry and out to SK2 until the fault is found.

Unstable or scrolling display

The computer may have lost its configuration value for SYNC. Type at the keyboard:

*CON. SYNC 1

press RESET and see if any change occurs. Check for CSYNC signal on SK2 pin 4. If not present, trace back through LK6, R96 and IC 63, finally changing VIDC IC 54.

Floppy disc drive

Make sure that the configuration items STEP and FLOPPIES are correctly set. Check that the disc drive ID selection switch is in the required position (usually 0). Swap the disc drive for a known good drive and cable. If this also fails, check the power supply connection for +12V, +5V and 0V.

Serial port

If a fault is reported but the test is passed, see the *Serial Port Application Note* in the *Archimedes 440 Service Manual* for possible explanations, noting that the A500 and R200 series serial port is now based on the RS232 standard, and the patch (RS423 Drive version 1.24) is no longer required.

Check for -5 V on IC 6 pin. Check for the clock on IC 2 pins 6 and 7; change X2 if faulty. If OK, change ICs 5 and 6.

Printer

If the printer fails completely, check for a STROBE signal on SK 3 pin 1, trace back through R 122, Q 4 and R 29 to IC 77. Also check for shorts or open circuits on PACK and PBSY.

If the data printed is incorrect, check the continuity of the data lines into and out of IC 79, though R 104, R83, R203, R196, R186, R172, R157, R140 and onto SK 3.

If both the printer and the floppy disc drive fail, change IC 43.

Keyboard and mouse

Check computer interface by swapping to a known good keyboard and mouse. If failure still present, check continuity of keyboard connector SK 11 and ensure that +5 V can be found on pin 4 and 0 V on pin 3.

Check functionality of inverting buffers in IC 3, check continuity through R 62 and R 101.

Check Ref 8M clock at IC58 pin 8 with a digital frequency meter. Replace IOC IC 58.

Expansion cards

Check through the section entitled *System Failure* on page 5-23, tracing all signals through to the expansion card backplane. If necessary, replace the expansion card backplane.

Part 6 - Parts lists

The parts lists in this chapter detail the components used in the manufacture of workstations and upgrades.

The parts lists are given under the following headings:

- Main PCB
- 4MB RAM upgrade card
- Backplane
- ARM3 daughter card (PGA)
- Keyboard and adaptor card (membrane keyboard) or Keyboard assembly (keyswitch keyboard)
- Ethernet I card or Ethernet II card
- SCSI interface card.

There is a circuit diagram for each of the above items. All the circuit diagrams are included at the back of this manual.

Contact the Spares Department of Acorn Computers Limited (account holders only), or its authorised dealers and Approved Service Centres, for information as to which parts are available as spares.

Main PCB assembly parts list

1	BARE PCB	1
2	PCB ASSEMBLY DWG (1 per batch)	1
3	PCB CIRCUIT DIAGRAM (1 per batch)	1
7	MAIN PCB REAR PANEL	1
12	CONR 2W SHUNT 0.1" fitted to LK2, 3, 6, 15(x2), 23 - 27	10
13	WIRE 22SWG CPR TIN A/R (X1, X2, X3)	
14	WIRE 25SWG CPR TIN (X3)	
15	LABEL SERIAL PCB	1
16	FOAM PAD (11x24mm) (BT1)	1
21	SKT IC 20/0.3" SUPA (IC21)	1
22	SKT IC 20/0.3" SUPA (IC39)	1
23	SKT IC 32/0.6" SUPA (IC47)	1
24	SKT IC 32/0.6" SUPA (IC48)	1
25	SKT IC 32/0.6" SUPA (IC49)	1
26	SKT IC 32/0.6" SUPA (IC50)	1
27	SKT IC 68P PLCC (IC58)	1
28	SKT IC 68P PLCC (IC60)	1
29	SKT IC 68P PLCC (IC64)	1
30	SKT IC 20/0.3" SUPA (IC66)	1
31	SKT IC 20/0.3" SUPA (IC71)	1
BT1	BAT NI-CAD 1V2 280MAH PCB	1
C1	CPCTR 10U TANT 10V 20% 5P	1
C2	CPCTR 10U TANT 10V 20% 5P	1
C3	CPCTR 10U TANT 10V 20% 5P	1
C4	CPCTR 10U TANT 10V 20% 5P	1
C5	CPCTR 220U ALEC 16V RAD	1
C6	CPCTR 220U ALEC 16V RAD	1
C7	CPCTR 47U ALEC 16V RAD	1
C8	CPCTR 4U7 ALEC 16V RAD	1
C9	CPCTR 47U ALEC 16V RAD	1
C10	CPCTR 100U ALEC 25V RAD	1
C11	CPCTR 10U ALEC 16V RAD	1
C12	CPCTR 10U ALEC 16V RAD	1
C13	CPCTR 220U ALEC 16V RAD	1
C14	CPCTR 4U7 ALEC 16V RAD	1
C15	CPCTR 100U ALEC 25V RAD	1
C16	CPCTR 47U ALEC 16V RAD	1
C17	CPCTR 100U ALEC 25V RAD	1
C18	CPCTR 10U ALEC 16V RAD	1
C19	CPCTR 220U ALEC 16V RAD	1
C20	CPCTR 220U ALEC 16V RAD	1
C21	CPCTR 220U ALEC 16V RAD	1
C22	CPCTR 47N CER 30V 80%	1
C23	CPCTR 47U ALEC 16V RAD	1
C24	CPCTR 220U ALEC 16V RAD	1
C25	CPCTR 47N CER 30V 80%	1
C26	CPCTR 47U ALEC 16V RAD	1
C27	CPCTR 220U ALEC 16V RAD	1
C28	CPCTR 47N CER 30V 80%	1
C29	CPCTR 47U ALEC 16V RAD	1
C30	CPCTR 220U ALEC 16V RAD	1
C31	CPCTR 10U ALEC 16V RAD	1
C32	CPCTR 47N CER 30V 80%	1
C33	CPCTR 47U ALEC 16V RAD	1
C34	CPCTR 10U ALEC 16V RAD	1
C35	CPCTR 220U ALEC 16V RAD	1
C36	CPCTR 10U ALEC 16V RAD	1
C37	CPCTR 220U ALEC 16V RAD	1
C38	CPCTR 33/47N DCPLR 0.2"	1
C39	CPCTR 22N MPSTR 50V 10%	1
C40	CPCTR 22N MPSTR 50V 10%	1
C41	CPCTR 100N MPSTR 50V 10%	1
C42	CPCTR 100N MPSTR 50V 10%	1
C43	CPCTR 100N DCPLR SMD1210	1
C44	CPCTR 100P CPLT 30V 2%	1
C45	CPCTR 470P CPLT 30V 10%	1
C46	CPCTR 100N DCPLR SMD1210	1
C47	CPCTR 470P CPLT 30V 10%	1
C48	CPCTR 18P CPLT 30V 2%	1
C49	CPCTR 100P CPLT 30V 2%	1
C50	CPCTR 2N2 CPLT 30V 10% 5P	1
C51	CPCTR 2N2 CPLT 30V 10% 5P	1
C52	CPCTR 33N DCPLR SMD1210	1
C53	CPCTR 2N2 CPLT 30V 10% 5P	1
C54	CPCTR 2N2 CPLT 30V 10% 5P	1
C55	CPCTR 100P CPLT 30V 2%	1

Item	Description	Qty
C56	CPCTR 2N2 CPLT 30V 10% 5P	1
C57	CPCTR 33P CPLT 30V 2%	1
C58	CPCTR 470P CPLT 30V 10%	1
C59		NF
C60	CPCTR 100P CPLT 30V 2%	1
C61	CPCTR 100P CPLT 30V 2%	1
C62	CPCTR 100P CPLT 30V 2%	1
C63	CPCTR 470P CPLT 30V 10%	1
C64		NF
C65	CPCTR 1N CPLT 30V 10%	1
C66	CPCTR 100P CPLT 30V 2%	1
C67		NF
C68	CPCTR 100P CPLT 30V 2%	1
C69	CPCTR 27P CPLT 30V 2%	1
C70	CPCTR 2N2 CPLT 30V 10% 5P	1
C71	CPCTR 1N CPLT 30V 10%	1
C72	CPCTR 15P CPLT 30V 2%	1
C73		NF
C74	CPCTR 100P CPLT 30V 2%	1
C75	CPCTR 18P CPLT 30V 2%	1
C76		NF
C77	CPCTR 1N CPLT 30V 10%	1
C78	CPCTR 47P CPLT 30V 2%	1
C79	CPCTR 1N CPLT 30V 10%	1
C80	CPCTR 100P CPLT 30V 2%	1
C81		NF
C82	CPCTR 1N CPLT 30V 10%	1
C83	CPCTR 47P CPLT 30V 2%	1
C84	CPCTR 1N CPLT 30V 10%	1
C85	CPCTR 100P CPLT 30V 2%	1
C86	CPCTR 1N CPLT 30V 10%	1
C87	CPCTR 47P CPLT 30V 2%	1
C88	CPCTR 1N CPLT 30V 10%	1
C89	CPCTR 1N CPLT 30V 10%	1
C90	CPCTR 1N CPLT 30V 10%	1
C91	CPCTR 1N CPLT 30V 10%	1
C92	CPCTR 100P CPLT 30V 2%	1
C93	CPCTR 1N CPLT 30V 10%	1
C94		NF
C95	CPCTR 100P CPLT 30V 2%	1
C96	CPCTR 1N CPLT 30V 10%	1
C97		NF
C98	CPCTR 100P CPLT 30V 2%	1
C99		NF
C100	CPCTR 100P CPLT 30V 2%	1
C101	CPCTR 100P CPLT 30V 2%	1
C102	CPCTR 33N DCPLR SMD1210	1
C103	CPCTR 33N DCPLR SMD1210	1
C104	CPCTR 33N DCPLR SMD1210	1
C105	CPCTR 33N DCPLR SMD1210	1
C106	CPCTR 33N DCPLR SMD1210	1
C107	CPCTR 33N DCPLR SMD1210	1
C108	CPCTR 33N DCPLR SMD1210	1
C109	CPCTR 33N DCPLR SMD1210	1
C110	CPCTR 33N DCPLR SMD1210	1
C111	CPCTR 33N DCPLR SMD1210	1
C112	CPCTR 33N DCPLR SMD1210	1
C113	CPCTR 33N DCPLR SMD1210	1
C114	CPCTR 33N DCPLR SMD1210	1
C115	CPCTR 33N DCPLR SMD1210	1
C116	CPCTR 33N DCPLR SMD1210	1
C117	CPCTR 33N DCPLR SMD1210	1
C118	CPCTR 33N DCPLR SMD1210	1
C119	CPCTR 33N DCPLR SMD1210	1
C120	CPCTR 33N DCPLR SMD1210	1
C121	CPCTR 33N DCPLR SMD1210	1
C122	CPCTR 33N DCPLR SMD1210	1
C123	CPCTR 33N DCPLR SMD1210	1
C124	CPCTR 33N DCPLR SMD1210	1
C125	CPCTR 33N DCPLR SMD1210	1
C126	CPCTR 33N DCPLR SMD1210	1
C127	CPCTR 33N DCPLR SMD1210	1
C128	CPCTR 33N DCPLR SMD1210	1
C129	CPCTR 33N DCPLR SMD1210	1
C130	CPCTR 33N DCPLR SMD1210	1
C131	CPCTR 33N DCPLR SMD1210	1
C132	CPCTR 33N DCPLR SMD1210	1
C133	CPCTR 33N DCPLR SMD1210	1
C134	CPCTR 33N DCPLR SMD1210	1
C135	CPCTR 33N DCPLR SMD1210	1
C136	CPCTR 33N DCPLR SMD1210	1
C137	CPCTR 33N DCPLR SMD1210	1

Item	Description	Qty
C138	CPCTR 33N DCPLR SMD1210	1
C139	CPCTR 33N DCPLR SMD1210	1
C140	CPCTR 33N DCPLR SMD1210	1
C141	CPCTR 33N DCPLR SMD1210	1
C142	CPCTR 33N DCPLR SMD1210	1
C143	CPCTR 33N DCPLR SMD1210	1
C144	CPCTR 33N DCPLR SMD1210	1
C145	CPCTR 33N DCPLR SMD1210	1
C146	CPCTR 33N DCPLR SMD1210	1
C147	CPCTR 33N DCPLR SMD1210	1
C148	CPCTR 33N DCPLR SMD1210	1
C149	CPCTR 33N DCPLR SMD1210	1
C150	CPCTR 100N DCPLR SMD1210	1
C151	CPCTR 100N DCPLR SMD1210	1
C152	CPCTR 100N DCPLR SMD1210	1
C153	CPCTR 100N DCPLR SMD1210	1
C154	CPCTR 100N DCPLR SMD1210	1
C155	CPCTR 100N DCPLR SMD1210	1
C156	CPCTR 100N DCPLR SMD1210	1
C157	CPCTR 100N DCPLR SMD1210	1
C158	CPCTR 100N DCPLR SMD1210	1
C159	CPCTR 33N DCPLR SMD1210	1
C160	CPCTR 100N DCPLR SMD1210	1
C161	CPCTR 100N DCPLR SMD1210	1
C162	CPCTR 100N DCPLR SMD1210	1
C163	CPCTR 33N DCPLR SMD1210	1
C164	CPCTR 100N DCPLR SMD1210	1
C165	CPCTR 100N DCPLR SMD1210	1
C166	CPCTR 100N DCPLR SMD1210	1
C167	CPCTR 33N DCPLR SMD1210	1
C168	CPCTR 100N DCPLR SMD1210	1
C169	CPCTR 100N DCPLR SMD1210	1
C170	CPCTR 100N DCPLR SMD1210	1
C171	CPCTR 33N DCPLR SMD1210	1
C172	CPCTR 100N DCPLR SMD1210	1
C173	CPCTR 100N DCPLR SMD1210	1
C174	CPCTR 100N DCPLR SMD1210	1
C175	CPCTR 100N DCPLR SMD1210	1
C176	CPCTR 100N DCPLR SMD1210	1
C177	CPCTR 100N DCPLR SMD1210	1
C178	CPCTR 100N DCPLR SMD1210	1
C179	CPCTR 100N DCPLR SMD1210	1
C180	CPCTR 100N DCPLR SMD1210	1
C181	CPCTR 100N DCPLR SMD1210	1
C182	CPCTR 100N DCPLR SMD1210	1
C183	CPCTR 100N DCPLR SMD1210	1
C184	CPCTR 33N DCPLR SMD1210	1
C185	CPCTR 33N DCPLR SMD1210	1
C186	CPCTR 10U TANT 10V 20% 5P	1
C187	CPCTR 10U TANT 10V 20% 5P	1
C188	CPCTR 10U TANT 10V 20% 5P	1
C189	CPCTR 10U TANT 10V 20% 5P	1
C190	CPCTR 10U TANT 10V 20% 5P	1
C191	CPCTR 10U TANT 10V 20% 5P	1
C192	CPCTR 10U TANT 10V 20% 5P	1
C193	CPCTR 10U TANT 10V 20% 5P	1
C194	CPCTR 10U TANT 10V 20% 5P	1
C195	CPCTR 10U TANT 10V 20% 5P	1
C196		NF
C197		NF
C198	CPCTR 33N DCPLR SMD1210	1
D1	DIODE SI 1N4005 600V 1A	1
D2	DIODE SI1N4148	1
D3	DIODE SI 1N4148	1
D4	DIODE SI 1N4148	1
D5	DIODE SI 1N4148	1
D6	DIODE SI 1N4148	1
D7	DIODE SI 1N4148	1
D8	DIODE SI 1N4148	1
D9	DIODE BAT85 SBL	1
D10	DIODE SI 1N418	1
D11	DIODE SI 1N418	1
D12	DIODE SI 1N418	1
D13	DIODE SI 1N418	1
D14	DIODE SI 1N418	1
D15	DIODE SI 1N418	1
FS1	FUSE 2AO F AX LEAD LBC	1
IC1	IC 74HCT14 CMOS 14/0.3"	1
IC2	IC 65C51 ACIA CMOS 2MHZ	1
IC3	IC 74HCT14 CMOS 14/0.3"	1
IC4	IC 74ACT174 CMOS 16/0.3"	1
IC5	IC 75189 RS232 RCVR	1
IC6	IC 75189 RS232 RCVR	1

Item	Description	Qty
IC7	IC 74ACT245 CMOS 20/0.3"	1
IC8	IC 74ACT153 CMOS 16/0.3"	1
IC9	IC 74HCT573 CMOS 20/0.3"	1
IC10	IC 74HCT573 CMOS 20/0.3"	1
IC11	IC DRAM 1MX1 20ZIP 80NS	1
IC12	IC DRAM 1MX1 20ZIP 80NS	1
IC13	IC DRAM 1MX1 20ZIP 80NS	1
IC14	IC DRAM 1MX1 20ZIP 80NS	1
IC15	IC DRAM 1MX1 20ZIP 80NS	1
IC16	IC DRAM 1MX1 20ZIP 80NS	1
IC17	IC 26LS30 RS422/423 DRVR	1
IC18	IC DRAM 1MX1 20ZIP 80NS	1
IC19	IC DRAM 1MX1 20ZIP 80NS	1
IC20	IC DRAM 1MX1 20ZIP 80NS	1
IC21	IC SLOW PAL [0760,203]	1
IC22	IC 8583 RTC RAM 8/0.3"	1
IC23	IC DRAM 1MX1 20ZIP 80NS	1
IC24	IC DRAM 1MX1 20ZIP 80NS	1
IC25	IC DRAM 1MX1 20ZIP 80NS	1
IC26	IC DRAM 1MX1 20ZIP 80NS	1
IC27	IC DRAM 1MX1 20ZIP 80NS	1
IC28	IC DRAM 1MX1 20ZIP 80NS	1
IC29	IC DRAM 1MX1 20ZIP 80NS	1
IC30	IC DRAM 1MX1 20ZIP 80NS	1
IC31	IC DRAM 1MX1 20ZIP 80NS	1
IC32	IC DRAM 1MX1 20ZIP 80NS	1
IC33	IC DRAM 1MX1 20ZIP 80NS	1
IC34	IC DRAM 1MX1 20ZIP 80NS	1
IC35	IC DRAM 1MX1 20ZIP 80NS	1
IC36	IC DRAM 1MX1 20ZIP 80NS	1
IC37	IC DRAM 1MX1 20ZIP 80NS	1
IC38	IC DRAM 1MX1 20ZIP 80NS	1
IC39	MMEMC ADD PAL [0760,203]	1
IC40	IC DRAM 1MX1 20ZIP 80NS	1
IC41	IC DRAM 1MX1 20ZIP 80NS	1
IC42	IC DRAM 1MX1 20ZIP 80NS	1
IC43	IC DRAM 1MX1 20ZIP 80NS	1
IC44	IC DRAM 1MX1 20ZIP 80NS	1
IC45	IC DRAM 1MX1 20ZIP 80NS	1
IC46	IC DRAM 1MX1 20ZIP 80NS	1
IC47	RISC OS 2.01 ROM1	1
IC48	RISC OS 2.01 ROM2	1
IC49	RISC OS 2.01 ROM3	1
IC50	RISC OS 2.01 ROM4	1
IC51	IC 74AC04 CMOS 14/0.3	1
IC52	IC 74AC04 CMOS 14/0.3	1
IC53	IC 74AC11 CMOS 14/0.3	1
IC54	IC 74S00 TTL 14/0.3	1
IC55	IC 7406 TTL 14/0.3"	1
IC56	IC 74AS21 TTL 14/0.3"	1
IC57	IC 74AS74 TTL 14/0.3	1
IC58	IC IOC PLSTC	1
IC59	IC 74AC32 CMOS 14/0.3"	1
IC60	IC MEMC1A 12MHZ PLSTC	1
IC61	IC 74F166 FAST 16/0.3	1
IC62	IC 74HC00 CMOS-14/0.3"	1
IC63	IC 74AC86 CMOS 14/0.3	1
IC64	IC VIDC 1A PLSTC	1
IC65	IC 74HC175 CMOS 16/0.3"	1
IC66	MEMC FAST PAL [0760,203]	1
IC67	IC 74HC573 CMOS 20/0.3"	1
IC68	IC 74HC573 CMOS 20/0.3"	1
IC69	IC 74HC573 CMOS 20/0.3"	1
IC70	IC 1772 FDC 28/0.6	1
IC71	MEMC SYNC PAL [0760,203]	1
IC72	IC 74ACT74 CMOS 14/0.3	1
IC73	IC 74AC574 CMOS 20/0.3	1
IC74	IC 74HCT573 CMOS 20/0.3"	1
IC75	IC 74HC138 CMOS 16/0.3"	1
IC76	IC 74HCT573 CMOS 20/0.3"	1
IC77	IC 74HC574 CMOS 20/0.3"	1
IC78	IC LM324 QUAD OP AMP	1
IC79	IC 74LS374 TTL 20/0.3"	1
IC80	IC LM386 AUDIO AMP	1
L1	CHOKE RF 2U2H AX Q=30	1
L2	CHOKE 80OHM/100MHZ	1
L3	CHOKE 80OHM/100MHZ	1
L4	CHOKE 80OHM/100MHZ	1
L5	CHOKE 80OHM/100MHZ	1
L6	CHOKE 80OHM/100MHZ	1
L7	CHOKE 80OHM/100MHZ	1
L8	CHOKE 80OHM/100MHZ	1
L9	CHOKE 80OHM/100MHZ	1

Item	Description	Qty
L10	CHOKE 80OHM/100MHZ	1
L11	CHOKE 80OHM/100MHZ	1
L12	CHOKE 80OHM/100MHZ	1
L13	CHOKE 80OHM/100MHZ	1
L14	CHOKE 80OHM/100MHZ	1
L15	CHOKE 80OHM/100MHZ	1
L16	CHOKE 80OHM/100MHZ	1
L17	CHOKE RF U22H AX Q=35 7X3	1
L18	CHOKE RF 33UH AX Q=45	1
LK1	CONR 6W WAFR 0.1" ST PCB	1
LK2	CONR 3W WAFR 0.1" ST PCB	1
LK3	CONR 3W WAFR 0.1" ST PCB	1
LK4	CONR 6W WAFR 0.1" ST PCB	1
LK5	CONR 2W WAFR 0.1" ST PCB	1
LK6	CONR 3W WAFR 0.1" ST PCB	1
LK7		NF
LK8		NF
LK9	CONR 10W WAFR 2ROW 0.1"	1
LK10		NF
LK11		NF
LK12		NF
LK13	CONR 2W WAFR 0.1" ST LK	1
LK14	CONR 2W WAFR 0.1" ST LK	1
LK15	CONR 16W WAFR 2ROW 0.1"	1
LK23	CONR 3W WAFR 0.1" ST PCB	1
LK24	CONR 3W WAFR 0.1" ST PCB	1
LK25	CONR 2W WAFR 0.1" ST PCB	1
LK26	CONR 3W WAFR 0.1" ST PCB	1
LK27	CONR 2W WAFR 0.1" ST PCB	1
LK29	CONR 6W WAFR 0.1" ST PCB	1
PL1	CONRD 9WPLG RA PCB+RFI+L	1
PL2	CONR 4W PLG PCB ST DISC P	1
PL3	CONR 96W PLG ST PCB REV	1
PL4	CONR 34W BOX IDC LP ST	1
PL5	CONR 6W PLG PCB DCPWR	1
PL6		NF
PL7		NF
PL8		NF
PL9		NF
PL10	FSTN TAB 6.3MMX0.8 ST PCB	1
PL11	FSTN TAB 6.3MMX0.8 ST PCB	1
Q1	TRANS BF689K NPN TO92 .1"	1
Q2	TRANS 2N3904 NPN TO92 .2"	1
Q3	TRANS 2N3906 PNP TO92 .2"	1
Q4	TRANS BC239C NPN TO92 .2"	1
Q5	TRANS 2N3906 PNP TO92 .2"	1
Q6	TRANS 2N3906 PNP TO92 .2"	1
Q7	TRANS 2N3906 PNP TO92 .2"	1
Q8	TRANS 2N3906 PNP TO92 .2"	1
Q10	TRANS 2N3906 PNP TO92 .2"	1
Q12	TRANS BC239C NPN TO92 .2"	1
Q13	TRANS BC239C NPN TO92 .2"	1
Q14	TRANS BC239C NPN TO92 .2"	1
R1	RES 4K7 SMD 5% 0W25 1206	1
R2	RES 4K7 SMD 5% 0W25 1206	1
R3	RES 4K7 SMD 5% 0W25 1206	1
R4	RES 4K7 SMD 5% 0W25 1206	1
R5	RES 4K7 SMD 5% 0W25 1206	1
R6	RES 4K7 SMD 5% 0W25 1206	1
R7	RES 4K7 SMD 5% 0W25 1206	1
R8	RES 33K SMD 5% 0W25 1206	1
R9	RES 1K2 SMD 5% 0W25 1206	1
R10	RES 10K SMD 5% 0W25 1206	1
R11	RES 10R SMD 5% 0W25 1206	1
R12	RES 22R SMD 5% 0W25 1206	1
R13	RES 1K2 SMD 5% 0W25 1206	1
R14	RES 10K SMD 5% 0W25 1206	1
R15	RES 220R SMD 5% 0W25 1206	1
R16	RES 4K7 SMD 5% 0W25 1206	1
R17	RES 1K0 SMD 5% 0W25 1206	1
R18	RES 2K2 SMD 5% 0W25 1206	1
R19	RES 4K7 SMD 5% 0W25 1206	1
R20	RES 330R SMD 5% 0W25 1206	1
R21	RES 6K8 SMD 5% 0W25 1206	1
R22	RES 68R SMD 5% 0W25 1206	1
R23	RES 1K0 SMD 5% 0W25 1206	1
R24	RES 180R SMD 5% 0W25 1206	1
R25	RES 100K SMD 5% 0W25 1206	1
R26	RES 1K0 SMD 5% 0W25 1206	1
R27	RES 1K0 SMD 5% 0W25 1206	1
R28	RES 220R SMD 5% 0W25 1206	1
R29	RES 1K0 SMD 5% 0W25 1206	1
R30	RES 68R SMD 5% 0W25 1206	1

Item	Description	Qty
R31	RES 33R SMD 5% 0W25 1206	1
R32	RES 1K0 SMD 5% 0W25 1206	1
R33	RES 180R SMD 5% 0W25 1206	1
R34	RES 100K SMD 5% 0W25 1206	1
R35	RES 100R SMD 5% 0W25 1206	1
R36	RES 1K0 SMD 5% 0W25 1206	1
R37	RES 10K SMD 5% 0W25 1206	1
R38	RES 10K SMD 5% 0W25 1206	1
R39	RES 56R SMD 5% 0W25 1206	1
R40	RES 100K SMD 5% 0W25 1206	1
R41	RES 68R SMD 5% 0W25 1206	1
R42	RES 100K SMD 5% 0W25 1206	1
R43	RES 4K7 SMD 5% 0W25 1206	1
R44	RES 1K0 SMD 5% 0W25 1206	1
R45	RES 47K SMD 5% 0W25 1206	1
R46	RES 100K SMD 5% 0W25 1206	1
R47	RES 33R SMD 5% 0W25 1206	1
R48	RES 68R SMD 5% 0W25 1206	1
R49	RES 68R SMD 5% 0W25 1206	1
R50	RES 33R SMD 5% 0W25 1206	1
R51	RES 1K0 SMD 5% 0W25 1206	1
R52	RES 10K SMD 5% 0W25 1206	1
R53	RES 10K SMD 5% 0W25 1206	1
R54	RES 33R SMD 5% 0W25 1206	1
R55	RES 3K3 SMD 5% 0W25 1206	1
R56	RES 68R SMD 5% 0W25 1206	1
R57	RES 33R SMD 5% 0W25 1206	1
R58	RES 68R SMD 5% 0W25 1206	1
R59	RES 1K0 SMD 5% 0W25 1206	1
R60	RES 100K SMD 5% 0W25 1206	1
R61	RES 100K SMD 5% 0W25 1206	1
R62	RES 2K2 SMD 5% 0W25 1206	1
R63	RES 68R SMD 5% 0W25 1206	1
R64	RES 68R SMD 5% 0W25 1206	1
R65	RES 68R SMD 5% 0W25 1206	1
R66	RES 68R SMD 5% 0W25 1206	1
R67	RES 33R SMD 5% 0W25 1206	1
R68	RES 68R SMD 5% 0W25 1206	1
R69	RES 1K0 SMD 5% 0W25 1206	1
R70	RES 10K SMD 5% 0W25 1206	1
R71	RES 2K2 SMD 5% 0W25 1206	1
R72	RES 56R SMD 5% 0W25 1206	1
R73	RES 3K3 SMD 5% 0W25 1206	1
R74	RES 68R SMD 5% 0W25 1206	1
R75	RES 10K SMD 5% 0W25 1206	1
R76	RES 680R SMD 5% 0W25 1206	1
R77	RES 1K0 SMD 5% 0W25 1206	1
R78	RES 10K SMD 5% 0W25 1206	1
R79	RES 100K SMD 5% 0W25 1206	1
R80	RES 330R SMD 5% 0W25 1206	1
R81	RES 68R SMD 5% 0W25 1206	1
R82	RES 1K0 SMD 5% 0W25 1206	1
R83	RES 22R SMD 5% 0W25 1206	1
R84	RES 68R SMD 5% 0W25 1206	1
R85	RES 68R SMD 5% 0W25 1206	1
R86	RES 68R SMD 5% 0W25 1206	1
R87	RES 33R SMD 5% 0W25 1206	1
R88	RES 33R SMD 5% 0W25 1206	1
R89	RES 33R SMD 5% 0W25 1206	1
R90	RES 1K0 SMD 5% 0W25 1206	1
R91	RES 1K0 SMD 5% 0W25 1206	1
R92	RES 56R SMD 5% 0W25 1206	1
R93	RES 33R SMD 5% 0W25 1206	1
R94	RES 3K3 SMD 5% 0W25 1206	1
R95	RES 68R SMD 5% 0W25 1206	1
R96	RES 68R SMD 5% 0W25 1206	1
R97	RES 330R SMD 5% 0W25 1206	1
R98	RES 1K0 SMD 5% 0W25 1206	1
R99	RES 100K SMD 5% 0W25 1206	1
R100	RES 100K SMD 5% 0W25 1206	1
R101	RES 220R SMD 5% 0W25 1206	1
R102	RES 68R SMD 5% 0W25 1206	1
R103	RES 1K0 SMD 5% 0W25 1206	1
R104	RES 22R SMD 5% 0W25 1206	1
R105	RES 68R SMD 5% 0W25 1206	1
R106	RES 68R SMD 5% 0W25 1206	1
R107	RES 68R SMD 5% 0W25 1206	1
R108	RES 33R SMD 5% 0W25 1206	1
R109	RES 33R SMD 5% 0W25 1206	1
R110	RES 33R SMD 5% 0W25 1206	1
R111	RES 330R SMD 5% 0W25 1206	1
R112	RES 33R SMD 5% 0W25 1206	1
R113	RES 33K SMD 5% 0W25 1206	1

Item	Description	Qty
R114	RES 3K3 SMD 5% 0W25 1206	1
R115	RES 3R3 SMD 5% 0W25 1206	1
R116	RES 68R SMD 5% 0W25 1206	1
R117	RES 4K7 SMD 5% 0W25 1206	1
R118	RES 100K SMD 5% 0W25 1206	1
R119	RES 100K SMD 5% 0W25 1206	1
R120	RES 68R SMD 5% 0W25 1206	1
R121	RES 68R SMD 5% 0W25 1206	1
R122	RES 22R SMD 5% 0W25 1206	1
R123	RES 4K7 SMD 5% 0W25 1206	1
R124	RES 68R SMD 5% 0W25 1206	1
R125	RES 68R SMD 5% 0W25 1206	1
R126	RES 68R SMD 5% 0W25 1206	1
R127	RES 33R SMD 5% 0W25 1206	1
R128	RES 33R SMD 5% 0W25 1206	1
R129	RES 68R SMD 5% 0W25 1206	1
R130	RES 1K0 SMD 5% 0W25 1206	1
R131	RES 10K SMD 5% 0W25 1206	1
R132	RES 3K3 SMD 5% 0W25 1206	1
R133	RES 3R3 SMD 5% 0W25 1206	1
R134	RES 68R SMD 5% 0W25 1206	1
R135	RES 4K7 SMD 5% 0W25 1206	1
R136	RES 100K SMD 5% 0W25 1206	1
R137	RES 100K SMD 5% 0W25 1206	1
R138	RES 68R SMD 5% 0W25 1206	1
R139	RES 68R SMD 5% 0W25 1206	1
R140	RES 22R SMD 5% 0W25 1206	1
R141	RES 4K7 SMD 5% 0W25 1206	1
R142	RES 68R SMD 5% 0W25 1206	1
R143	RES 68R SMD 5% 0W25 1206	1
R144	RES 68R SMD 5% 0W25 1206	1
R145	RES 68R SMD 5% 0W25 1206	1
R146	RES 33R SMD 5% 0W25 1206	1
R147	RES 33R SMD 5% 0W25 1206	1
R148	RES 68R SMD 5% 0W25 1206	1
R149	RES 10K SMD 5% 0W25 1206	1
R150	RES 3K3 SMD 5% 0W25 1206	1
R151	RES 330R SMD 5% 0W25 1206	1
R152	RES 68R SMD 5% 0W25 1206	1
R153	RES 100K SMD 5% 0W25 1206	1
R154	RES 100K SMD 5% 0W25 1206	1
R155	RES 68R SMD 5% 0W25 1206	1
R156	RES 68R SMD 5% 0W25 1206	1
R157	RES 22R SMD 5% 0W25 1206	1
R158	RES 47K SMD 5% 0W25 1206	1
R159	RES 68R SMD 5% 0W25 1206	1
R160	RES 68R SMD 5% 0W25 1206	1
R161	RES 68R SMD 5% 0W25 1206	1
R162	RES 68R SMD 5% 0W25 1206	1
R163	RES 33R SMD 5% 0W25 1206	1
R164	RES 33R SMD 5% 0W25 1206	1
R165	RES 4K7 SMD 5% 0W25 1206	1
R166	RES 10K SMD 5% 0W25 1206	1
R167	RES 4K7 SMD 5% 0W25 1206	1
R168	RES 68R SMD 5% 0W25 1206	1
R169	RES 100K SMD 5% 0W25 1206	1
R170	RES 68R SMD 5% 0W25 1206	1
R171	RES 68R SMD 5% 0W25 1206	1
R172	RES 22R SMD 5% 0W25 1206	1
R173	RES 4K7 SMD 5% 0W25 1206	1
R174	RES 68R SMD 5% 0W25 1206	1
R175	RES 68R SMD 5% 0W25 1206	1
R176	RES 68R SMD 5% 0W25 1206	1
R177	RES 68R SMD 5% 0W25 1206	1
R178	RES 33R SMD 5% 0W25 1206	1
R179	RES 33R SMD 5% 0W25 1206	1
R180	RES 33R SMD 5% 0W25 1206	1
R181	RES 33R SMD 5% 0W25 1206	1
R182	RES 10K SMD 5% 0W25 1206	1
R183	RES 4K7 SMD 5% 0W25 1206	1
R184	RES 68R SMD 5% 0W25 1206	1
R185	RES 68R SMD 5% 0W25 1206	1
R186	RES 22R SMD 5% 0W25 1206	1
R187	RES 4K7 SMD 5% 0W25 1206	1
R188	RES 68R SMD 5% 0W25 1206	1
R189	RES 68R SMD 5% 0W25 1206	1
R190	RES 68R SMD 5% 0W25 1206	1
R191	RES 68R SMD 5% 0W25 1206	1
R192	RES 33R SMD 5% 0W25 1206	1
R193	RES 68R SMD 5% 0W25 1206	1
R194	RES 33R SMD 5% 0W25 1206	1
R195	RES 68R SMD 5% 0W25 1206	1
R196	RES 22R SMD 5% 0W25 1206	1

Item	Description	Qty
R197	RES 4K7 SMD 5% 0W25 1206	1
R198	RES 68R SMD 5% 0W25 1206	1
R199	RES 68R SMD 5% 0W25 1206	1
R200	RES 68R SMD 5% 0W25 1206	1
R201	RES 68R SMD 5% 0W25 1206	1
R202	RES 33R SMD 5% 0W25 1206	1
R203	RES 22R SMD 5% 0W25 1206	1
R204	RES 4K7 SMD 5% 0W25 1206	1
R205	RES 68R SMD 5% 0W25 1206	1
R206	RES 33R SMD 5% 0W25 1206	1
R207	RES 1K2 SMD 5% 0W25 1206	1
R208	RES 10K SMD 5% 0W25 1206	1
R209	RES 1K0 SMD 5% 0W25 1206	1
R210	RES 1K0 SMD 5% 0W25 1206	1
R211	RES 1K0 SMD 5% 0W25 1206	1
R212	RES 43R2 MF 1% 0W25 E96	1
R213	RES 43R2 MF 1% 0W25 E96	1
R214	RES 22K1 MF 1% 0W25 E96	1
R215	RES 22K1 MF 1% 0W25 E96	1
R216	RES 22K1 MF 1% 0W25 E96	1
R217	RES 220R SMD 5% 0W25 1206	1
R218	RES 43R2 MF 1% 0W25 E96	1
R219	RES 22K1 MF 1% 0W25 E96	1
R220	RES 220R SMD 5% 0W25 1206	1
R221	RES 100K SMD 5% 0W25 1206	1
R222	RES 22K1 MF 1% 0W25 E96	1
R223	RES 22K1 MF 1% 0W25 E96	1
R224	RES 150R SMD 5% 0W25 1206	1
R225	RES 100K SMD 5% 0W25 1206	1
R226	RES 1K00 MF 1% 0W25 E96	1
R227	RES 22K1 MF 1% 0W25 E96	1
R228	RES 330R SMD 5% 0W25 1206	1
R229	RES 100K SMD 5% 0W25 1206	1
R230	RES 332R MF 1% 0W25 E96	1
R231	RES 1K00 MF 1% 0W25 E96	1
R232	RES 330R SMD 5% 0W25 1206	1
R233	RES 100K SMD 5% 0W25 1206	1
R234	RES 332R MF 1% 0W25 E96	1
R235	RES 1K00 MF 1% 0W25 E96	1
R236	RES 150R SMD 5% 0W25 1206	1
R237	RES 33K SMD 5% 0W25 1206	1
R238	RES 332R MF 1% 0W25 E96	1
R239	RES 1K00 MF 1% 0W25 E96	1
R240	RES 150R SMD 5% 0W25 1206	1
R241	RES 33K SMD 5% 0W25 1206	1
R242	RES 22K1 MF 1% 0W25 E96	1
R243	RES 1K8 SMD 5% 0W25 1206	1
R244	RES 560R SMD 5% 0W25 1206	1
R245	RES 10K SMD 5% 0W25 1206	1
R246	RES 100K SMD 5% 0W25 1206	1
R247	RES 100K SMD 5% 0W25 1206	1
R248	RES 100K SMD 5% 0W25 1206	1
R249	RES 100K SMD 5% 0W25 1206	1
R250	RES 10R SMD 5% 0W25 1206	1
R251	RES 1K0 SMD 5% 0W25 1206	1
R252	RES 1K0 SMD 5% 0W25 1206	1
R253	RES 1K0 SMD 5% 0W25 1206	1
R254	RES 1K0 SMD 5% 0W25 1206	1
R255	RES 22R SMD 5% 0W25 1206	1
R256	RES 33R SMD 5% 0W25 1206	1
R257	RES 22R SMD 5% 0W25 1206	1
R258	RES 22R SMD 5% 0W25 1206	1
R259	RES 22R SMD 5% 0W25 1206	1
R260	RES 22R SMD 5% 0W25 1206	1
R261	RES 33R SMD 5% 0W25 1206	1
R262	RES 33R SMD 5% 0W25 1206	1
R263	RES 33R SMD 5% 0W25 1206	1
R264	RES 33R SMD 5% 0W25 1206	1
R265	RES 33R SMD 5% 0W25 1206	1
R266	RES 33R SMD 5% 0W25 1206	1
R267	RES 33R SMD 5% 0W25 1206	1
R268	RES 33R SMD 5% 0W25 1206	1
R269	RES 33R SMD 5% 0W25 1206	1
R270	RES 33R SMD 5% 0W25 1206	1
R271	RES 33R SMD 5% 0W25 1206	1
R272	RES 33R SMD 5% 0W25 1206	1
R273	RES 33R SMD 5% 0W25 1206	1
R274	RES 33R SMD 5% 0W25 1206	1
R275	RES 68R SMD 5% 0W25 1206	1
R276	RES 33R SMD 5% 0W25 1206	1
R277	RES 33R SMD 5% 0W25 1206	1
R278	RES 33R SMD 5% 0W25 1206	1
R279	RES 22R SMD 5% 0W25 1206	1

Item	Description	Qty
R280	RES 33R SMD 5% 0W25 1206	1
R281	RES 33R SMD 5% 0W25 1206	1
R282	RES 33R SMD 5% 0W25 1206 00	1
R283	RES 33R SMD 5% 0W25 1206	1
R284	RES 33R SMD 5% 0W25 1206	1
R285	RES 33R SMD 5% 0W25 1206	1
R286	RES 33R SMD 5% 0W25 1206	1
R287	RES 68R SMD 5% 0W25 1206	1
R288	RES 1K0 SMD 5% 0W25 1206	1
R289	RES 1K0 SMD 5% 0W25 1206	1
R290	RES 33R SMD 5% 0W25 1206	1
SK1	CONR JKSKT 3W 3,5MM RAPCB	1
SK2	CONRD 9WSKT RA PCB+RFI+L	1
SK3	CONRD 25W SKT RAPCB+RFI+L	1
SK4	CONR 5W SKT DIN SCRPN PCB	1
SK5	CONR 96W SKT ST ABC PCB	1
SK6	CONR 96W SKT ST ABC PCB	1
SK7	CONR 96W SKT ST ABC PCB	1
SK8	CONR 5W SKT HSNQ 0.1" PCB	1
SK9	CONR 96W SKT ST ABC PCB	1
SK10	CONR 17W SKT HSNQ .1" PCB	1
SK11	SKT 6W MINDIN RA PCB RFI	1
SK12	CONR BNC SKT RAPCB METAL	1
SK13	CONR BNC SKT RAPCB METAL	1
SK14	CONR BNC SKT RAPCB METAL	1
X1	XTAL 96MHZ HC18 5TH O/T	1
X2	XTAL 1.8432MHZ HC18	1
X3	XTAL 32.768KHZ CC 0.05P	1
X4	XTAL OSC 72.00MHZ 14/0.3"	1
X5		NF
X6	XTAL OSC 36.00MHZ 14/0.3"	1
X7	XTAL OSC 25.175MHZ 14/0.3	1

4MB RAM card (optional upgrade)

Item	Description	Qty
1	BARE PCB	1
2	PCB ASSEMBLY DRG	1
3	PCB CIRCUIT DIAGRAM	1
15	LABEL SERIAL PCB	1
C1	CPCTR 47U TANT SMD	1
C2	CPCTR 47U TANT SMD	1
C3	CPCTR 47U TANT SMD	1
C4	CPCTR 47U TANT SMD	1
C5	CPCTR 33N DCPLR SMD1210	1
C6	CPCTR 33N DCPLR SMD1210	1
C7	CPCTR 33N DCPLR SMD1210	1
C8	CPCTR 33N DCPLR SMD1210	1
C9	CPCTR 33N DCPLR SMD1210	1
C10	CPCTR 33N DCPLR SMD1210	1
C11	CPCTR 33N DCPLR SMD1210	1
C12	CPCTR 33N DCPLR SMD1210	1
C13	CPCTR 33N DCPLR SMD1210	1
C14	CPCTR 33N DCPLR SMD1210	1
IC1	IC 1MX4 DRAM 80NS SOJ	1
IC2	IC 1MX4 DRAM 80NS SOJ	1
IC3	IC 1MX4 DRAM 80NS SOJ	1
IC4	IC 1MX4 DRAM 80NS SOJ	1
IC5	IC 1MX4 DRAM 80NS SOJ	1
IC6	IC 1MX4 DRAM 80NS SOJ	1
IC7	IC 1MX4 DRAM 80NS SOJ	1
IC8	IC 1MX4 DRAM 80NS SOJ	1
IC9	IC 74AC04 CMOS 14P SMD	1
IC10	IC MEMC1A 12MHZ PLSTC	1
L1	CHOKE 80R/100MHZ SMD	1
L2	CHOKE 80R/100MHZ SMD	1
L3	CHOKE 80R/100MHZ SMD	1
PL1	CONR 96W PLG RA ABC PCB	1
R1	RES 68R SMD 5% 0W25 1206	1
R2	RES 68R SMD 5% 0W25 1206	1
R3	RES 68R SMD 5% 0W25 1206	1
R4	RES 68R SMD 5% 0W25 1206	1
R5	RES 68R SMD 5% 0W25 1206	1
R6	RES 68R SMD 5% 0W25 1206	1
R7	RES 68R SMD 5% 0W25 1206	1
R8	RES 68R SMD 5% 0W25 1206	1
R9	RES 68R SMD 5% 0W25 1206	1
R10	RES 68R SMD 5% 0W25 1206	1
R11	RES 68R SMD 5% 0W25 1206	1
R12	RES 68R SMD 5% 0W25 1206	1
R13	RES 68R SMD 5% 0W25 1206	1
R14	RES 68R SMD 5% 0W25 1206	1
R15	RES 68R SMD 5% 0W25 1206	1
R16	RES 68R SMD 5% 0W25 1206	1
R17	RES 68R SMD 5% 0W25 1206	1
R18	RES 68R SMD 5% 0W25 1206	1
R19	RES 68R SMD 5% 0W25 1206	1
R20	RES 68R SMD 5% 0W25 1206	1
R21	RES 68R SMD 5% 0W25 1206	1
R22	RES 68R SMD 5% 0W25 1206	1
R23	RES 68R SMD 5% 0W25 1206	1
R24	RES 68R SMD 5% 0W25 1206	1
R25	RES 68R SMD 5% 0W25 1206	1
R26	RES 68R SMD 5% 0W25 1206	1
R27	RES 68R SMD 5% 0W25 1206	1
R28	RES 68R SMD 5% 0W25 1206	1
R29	RES 68R SMD 5% 0W25 1206	1
R30	RES 68R SMD 5% 0W25 1206	1
R31	RES 68R SMD 5% 0W25 1206	1
R32	RES 68R SMD 5% 0W25 1206	1
R33	RES 33R SMD 5% 0W25 1206	1
R34	RES 33R SMD 5% 0W25 1206	1
R35	RES 33R SMD 5% 0W25 1206	1
R36	RES 33R SMD 5% 0W25 1206	1
R37	RES 33R SMD 5% 0W25 1206	1
R38	RES 33R SMD 5% 0W25 1206	1
R39	RES 33R SMD 5% 0W25 1206	1
R40	RES 33R SMD 5% 0W25 1206	1

Notes on MEMC:

MEMCs **MUST** be Acorn Part Number 2201,393, to ensure correct timing parameters.

To allow for future expansion, PL1 pins A25,16 and 8 should be left open circuit, not connected to +5V. This change will be carried out on any future issue of the PCB.

Backplane adaptor

Item	Description	Qty
1	BARE PCB	1
2	PCB ASSEMBLY DRG (1 PER BATCH)	1
3	PCB CIRCUIT DIAGRAM (1 PER BATCH)	1
15	LABEL SERIAL PCB 15x50mm	1
C1	CPCTR 33/47N DCPLR 0.2"	1
C2	CPCTR 33/47N DCPLR 0.2"	1
C3	CPCTR 33/47N DCPLR 0.2"	1
C4	CPCTR 47U ALEC 16V AX	1
C5	CPCTR 47U ALEC 16V AX	1
C6	CPCTR 47U ALEC 16V AX	1
IC1	IC 74HC139 CMOS 16/0.3"	1
IC2	BP INT MASK PAL(0760003)	1
IC3	BP INT MASK PAL(0760003)	1
PL1	CONR 96W PLG RA ABC PCB	1
R1	RES 10K C/MF 5% 0W25	1
R2	RES 10K C/MF 5% 0W25	1
R3	RES 10K C/MF 5% 0W25	1
R4	RES 10K C/MF 5% 0W25	1
SK1	CONR 64W SKT ST AC PCB SH	1
SK2	CONR 64W SKT ST AC PCB SH	1
SK3	CONR 64W SKT ST AC PCB SH	1
SK4	CONR 64W SKT ST AC PCB SH	1

ARM3 (PGA) Daughter card

Item	Description	Qty
1	BARE PCB	1
2	PCB ASSEMBLY DRG	1
3	PCB CIRCUIT DIAGRAM	1
15	LABEL SERIAL PCB	1
C1	CPCTR 47U ALEC 10V AX	1
C2	CPCTR 47U ALEC 10V AX	1
C3	CPCTR 22P CPLT 30V 2%	1
C4	CPCTR 33N DCPLR SMD1210	1
C5	CPCTR 33N DCPLR SMD1210	1
C6	CPCTR 33N DCPLR SMD1210	1
C7	CPCTR 33N DCPLR SMD1210	1
IC1	ARM3 CPU (PGA)	1
IC2	IC 74ACT74 CMOS 14/0.3	1
R1	RES 10K SMD 5% 0W25 1206	1
R2	RES 68R SMD 5% 0W25 1206	1
R4	RES 100R SMD 5% 0W25 1206	1
R5	RES 22R SMD 5% 0W25 1206	1
R6	RES 22R SMD 5% 0W25 1206	1
R7	RES 22R SMD 5% 0W25 1206	1
R8	RES 22R SMD 5% 0W25 1206	1
R9	RES 22R SMD 5% 0W25 1206	1
R10	RES 22R SMD 5% 0W25 1206	1
R11	RES 22R SMD 5% 0W25 1206	1
R12	RES 22R SMD 5% 0W25 1206	1
R13	RES 22R SMD 5% 0W25 1206	1
R14	RES 22R SMD 5% 0W25 1206	1
R15	RES 22R SMD 5% 0W25 1206	1
R16	RES 22R SMD 5% 0W25 1206	1
R17	RES 22R SMD 5% 0W25 1206	1
R18	RES 22R SMD 5% 0W25 1206	1
R19	RES 22R SMD 5% 0W25 1206	1
R20	RES 22R SMD 5% 0W25 1206	1
R21	RES 22R SMD 5% 0W25 1206	1
R22	RES 22R SMD 5% 0W25 1206	1
R23	RES 22R SMD 5% 0W25 1206	1
R24	RES 22R SMD 5% 0W25 1206	1
R25	RES 22R SMD 5% 0W25 1206	1
R26	RES 22R SMD 5% 0W25 1206	1
R27	RES 22R SMD 5% 0W25 1206	1
R28	RES 22R SMD 5% 0W25 1206	1
R29	RES 22R SMD 5% 0W25 1206	1
R30	RES 22R SMD 5% 0W25 1206	1
R31	RES 22R SMD 5% 0W25 1206	1
R32	RES 22R SMD 5% 0W25 1206	1
R33	RES 22R SMD 5% 0W25 1206	1
R34	RES 22R SMD 5% 0W25 1206	1
R35	RES 22R SMD 5% 0W25 1206	1
R36	RES 22R SMD 5% 0W25 1206	1
R37	RES 22R SMD 5% 0W25 1206	1
R38	RES 22R SMD 5% 0W25 1206	1
R39	RES 22R SMD 5% 0W25 1206	1
R40	RES 22R SMD 5% 0W25 1206	1
R41	RES 22R SMD 5% 0W25 1206	1
R42	RES 22R SMD 5% 0W25 1206	1
R43	RES 22R SMD 5% 0W25 1206	1
R44	RES 22R SMD 5% 0W25 1206	1
R45	RES 22R SMD 5% 0W25 1206	1
R46	RES 22R SMD 5% 0W25 1206	1
R47	RES 22R SMD 5% 0W25 1206	1
R48	RES 22R SMD 5% 0W25 1206	1
R49	RES 22R SMD 5% 0W25 1206	1
R50	RES 22R SMD 5% 0W25 1206	1
R51	RES 22R SMD 5% 0W25 1206	1
R52	RES 22R SMD 5% 0W25 1206	1
R53	RES 22R SMD 5% 0W25 1206	1
R54	RES 22R SMD 5% 0W25 1206	1
R55	RES 22R SMD 5% 0W25 1206	1
R56	RES 22R SMD 5% 0W25 1206	1
R57	RES 22R SMD 5% 0W25 1206	1
R58	RES 22R SMD 5% 0W25 1206	1
R59	RES 22R SMD 5% 0W25 1206	1
R60	RES 22R SMD 5% 0W25 1206	1
R61	RES 22R SMD 5% 0W25 1206	1
R62	RES 22R SMD 5% 0W25 1206	1
R63	RES 22R SMD 5% 0W25 1206	1
R64	RES 22R SMD 5% 0W25 1206	1
R65	RES 22R SMD 5% 0W25 1206	1
R66	RES 22R SMD 5% 0W25 1206	1
R67	RES 22R SMD 5% 0W25 1206	1
R68	RES 22R SMD 5% 0W25 1206	1
SK1	CONR 96W SKT RA PCB REV	1
X1	XTAL OSC 14/0.3"	1

Keyboard adaptor PCB (membrane keyboard)

Item	Description	Qty
1	BARE PCB	1
2	PCB ASSEMBLY DWG (1 PER BATCH)	1
3	PCB CIRCUIT DIAGRAM (1 PER BATCH)	1
9	KEYBOARD CABLE ASSEMBLY	1
16	LABEL SERIAL PCB	1
19	WIRE 25SWG CPR TIN (A/R X1)	1
21	SKT IC 40/0.6" SUPA (IC3)	1
C1	CPCTR 1N CPLT 30V 10%	1
C2	CPCTR 1N CPLT 30V 10%	1
C3	CPCTR 1N CPLT 30V 10%	1
C4	CPCTR 1N CPLT 30V 10%	1
C5	CPCTR 47U ALEC 10V AX	1
C6	CPCTR 33/47N DCPLR 0.2"	1
C7	CPCTR 33/47N DCPLR 0.2"	1
C8	CPCTR 27P CPLT 30V 2%	1
C9	CPCTR 33/47N DCPLR 0.2"	1
C10	CPCTR 27P CPLT 30V 2%	1
C11	CPCTR 33/47N DCPLR 0.2"	1
C12	CPCTR 33/47N DCPLR 0.2"	1
C13	CPCTR 33/47N DCPLR 0.2"	1
C14	CPCTR 4U7 ALEC 10V AX	1
C15	CPCTR 47U ALEC 10V AX	1
C16	CPCTR 1N CPLT 30V 10%	1
C17	CPCTR 1N CPLT 30V 10%	1
C18	CPCTR 1N CPLT 30V 10%	1
C19	CPCTR 1N CPLT 30V 10%	1
C20	CPCTR 1N CPLT 30V 10%	1
C21	CPCTR 1N CPLT 30V 10%	1
C22	CPCTR 1N CPLT 30V 10%	1
C23	CPCTR 1N CPLT 30V 10%	1
IC1	IC 74HCT4051 CMOS 16/0.3"	1
IC2	IC 74HCT4051 CMOS 16/0.3"	1
IC3	IC KBD CTRLR {0708,051}	1
IC4	IC 74HC14 CMOS 14/0.3"	1
IC5	IC 74HCT4051 CMOS 16/0.3"	1
IC6	IC 74HCT14 CMOS 14/0.3"	1
L1	CHOKO 80OHM/100MHZ	1
LK1		NF
LK2		NF
LK3		NF
LK4		NF
LK5		NF
LK6		NF
LK7		NF
R1	RES 220R C/MF 5% 0W25	1
R2	RES 330R C/MF 5% 0W25	1
R3	RES 47K C/MF 5% 0W25	1
R4	RES 47K C/MF 5% 0W25	1
R5	RES 47K C/MF 5% 0W25	1
R6	RES 47K C/MF 5% 0W25	1
R7	RES 47K C/MF 5% 0W25	1
R8	RES 47K C/MF 5% 0W25	1
R9	RES 47K C/MF 5% 0W25	1
R10	RES 47K C/MF 5% 0W25	1
R11	RES 47K C/MF 5% 0W25	1
R12	RES 47K C/MF 5% 0W25	1
R13	RES 47K C/MF 5% 0W25	1
R14	RES 47K C/MF 5% 0W25	1
R15	RES 47K C/MF 5% 0W25	1
R16	RES 270R C/MF 5% 0W25	1
R17	RES 47K C/MF 5% 0W25	1
R18	RES 47K C/MF 5% 0W25	1
R19	RES 47K C/MF 5% 0W25	1
R20	RES 4K7 C/MF 5% 0W25	1
R21	RES 10K C/MF 5% 0W25	1
R22	RES 330R C/MF 5% 0W25	1
R23	RES 330R C/MF 5% 0W25	1
R24	RES 10K C/MF 5% 0W25	1
R25	RES 330R C/MF 5% 0W25	1
R26	RES 10K C/MF 5% 0W25	1
R27	RES 220R C/MF 5% 0W25	1
R28	RES 270R C/MF 5% 0W25	1
R29	RES 10K C/MF 5% 0W25	1
R30	RES 10K C/MF 5% 0W25	1
R31	RES 10K C/MF 5% 0W25	1
R32	RES 10K C/MF 5% 0W25	1
R33	RES 22K C/MF 5% 0W25	1
R34	RES 100R C/MF 5% 0W25	1
R35	RES 100R C/MF 5% 0W25	1
SK1	CONR 20W FLEX PCB	1

**Keyboard adaptor PCB (cont)
(membrane keyboard)**

Item	Description	Qty
SK2	CONR 20W FLEX PCB	1
SK3	CONR 9W SKT M/DIN RA RFI	1
SW1	SW 2P MOM CO P/B RA PCB	1
X1	XTAL 12.00MHZ HC18	1

Keyboard assembly (keyswitch keyboard)

This is a service replacement item. Part numbers:

- 0186,012 (keyboard subassembly)
- 0086,900/A (complete keyboard unit).

Ethernet I

Item	Description	Qty
	BARE PCB	1
	ASSEMBLY DRAWING	1*
	CIRCUIT DIAGRAM	1*
IC13	IC GAL 1 (0760,200 TBP)	1
IC14	IC GAL 2 (0760,200 TBP)	1
IC15	IC GAL 3 (0760,200 TBP)	1
IC12	IC PROM (0702,719 TBP)	1
	ETHER/CHEAPER NET REAR PNL	1
	PCB SUPPORT MOUNTING BRKT	1
R18	RES 4K7 C/MF 5% 0W25	1
R12-15	RES 39R2 MF 1% 0W25 E96	4
R7-10	RES 43R2 MF 1% 0W25 E96	4
R6	RES 78R7 MF 1% 0W25 E96	1
R2,3,16	RES 243R MF 0%5 0W25	3
R11	RES 1M0 HIVOLT 5% 0W25	1
RP1	RES 10Kx5 NET SIL 6P 5%	1
C1,2	CPCTR CPLT 33p 30V 2%	2
C4,5,9,10,15	CPCTR ALEC 47uF 16V RAD	5
C8	CPCTR CML 220n 25V 80%	1
C18,19	CPCTR CER 10n 100V 20%	2
C13	CPCTR MPSTR 22n 50V 10%	1
C3	CPCTR CLASY 10n 250V 20%	1
A,C6,7,14,16,17	CPCTR DCPLR 33/47n 0.2"	12
IC10,11	IC 62256 SRAM 100nS 32Kx8	2
IC16	IC 82501 SIA NMOS 20/0.3"	1
IC17	IC 82502 TRAN MOS 16/0.3"	1
IC1	IC 82586 LAN NMOS 48/0.6"	1
IC2,3	IC 74HCT244 CMOS 20/0.3"	2
IC6,7,8,9	IC 74HCT245 CMOS 20/0.3"	4
IC4,5	IC 74HCT573 CMOS 20/0.3"	2
IC18	IC 74ACT240 CMOS 20/0.3"	1
DC1	(was DC)DC/DC CONV 12V TO 5V,10V	1
Q1	(was TR1)TRANS BC239 NPN TO92 EBC	1
D1,2	DIODE IN4150 SI 50V DO35	2
LK10	CONR WAFR 3W 0.1" ST PCB	1
LK3-8,10	CONR 2W SHUNT 0.1"	7
SKT	IC 16/03" SUPA	1
	USE ON IC17	
SKT	IC 20/0.3" SUPA	1
	USE ON IC16	
SKT	IC 48/0.6" SUPA	1
	USE ON IC1	
SK1	(was PL2)CONR 15W SKT RA PCB+RFI	1
PL1	CONR 64W PLG RA AC PCB	1
LK3-8	CONR WAFR 6W 0.1" ST PCB	3
PL3	CONR BNC SKT PNL 50R INSU	1
	15W D SLIDE LOCK ASSY	1
	USE ON SK1	
X1	XTAL 20MHZ HC18 20PF P/L	1
T1	ISO TRANS 16PIN DIL 0.3"	1
WIRE	22SWG CPR TIN	A/R
	USE ON X1,PL3	
SCW	M2.5x6 PAN HD POSI	4
	USE ON 1,16,17	
SCW	M3x10 PAN HD POSI	2
	USE ON 1,17,89	
NUT	M2.5 STL FULL Z/PAS	2
	USE ON 108	
NUT	M3 STL FULL Z/PAS	2
	USE ON 96,109	
WSHR	M2.5 SPRF IT STL	2
	USE ON 108	
WSHR	M3 SPRF IT STL	2
	USE ON 96,109	
	*1 PER BATCH	

Ethernet II

Item	Description	Qty
1	BARE PCB	1
2	ASSEMBLY DRAWING	1*
3	CIRCUIT DIAGRAM	1*
7	ETHERNET II REAR PANEL	1
8	PCB SUPPORT MOUNTING BRKT	1
11	CONR 2W SHUNT 0.1" LK3 to 8	6
13	SKT IC 20/0.3" SUPA IC10,14,18,19	4
14	SKT IC 32/0.6" SUPA IC6	1
15	SKT IC 68W PLCC IC3	1
16	SKT IC 28W PLCC IC1	1
18	15W D SLIDE LOCK ASSY SK1	1
19		
20	WIRE 22SWG CPR TIN X1,SK2	A/R
22	SCW M2,5x6 PAN HD POSI USE WITH ITEMS 1,7 & 8	4
23	SCW M3x10 PAN HD POSI USE WITH ITEMS 1,8 & SK1	2
25	NUT M2,5 STL FULL Z/PAS USED WITH ITEM 22	2
26	NUT M3 STL FULL Z/PAS USED WITH ITEM 23	2
28	WSHR M2,5 SPRF IT STL USED WITH ITEM 22	4
29	WSHR M3 SPRF IT STL USED WITH ITEM 23	2
R1	RES 39R2 MF 1% 0W25 E96	1
R2	RES 39R2 MF 1% 0W25 E96	1
R3	RES 68R C/MF 5% 0W25	1
R4	RES 39R2 MF 1% 0W25 E96	1
R5	RES 100K C/MF 5% 0W25	1
R6	RES 39R2 MF 1% 0W25 E96	1
R7	RES 1K00 MF 1% 0W25 E96	1
R8	RES 1K5 C/MF 5% 0W25	1
R9	RES 274R MF 1% 0W25 E96	1
R10	RES 220R C/MF 5% 0W25	1
R11	RES 1K5 C/MF 5% 0W25	1
R12	RES 274R MF 1% 0W25 E96	1
R13	RES 1K5 C/MF 5% 0W25	1
R14	RES 1M0 HIVOLT 5% 0W25	1
R15	RES 56R C/MF 5% 0W25	1
RP1	RESNET 1K5x7 SIL 8P 2%	1
RP2	RESNET 1K5x7 SIL 8P 2%	1
C1	CPCTR 100U ALEC 25V RAD	1
C2	CPCTR ALEC 47uF 16V RAD	1
C3	CPCTR ALEC 47uF 16V RAD	1
C4	CPCTR DCPLR 33/47n 0.2"	1
C5	CPCTR DCPLR 33/47n 0.2"	1
C6	CPCTR DCPLR 33/47n 0.2"	1
C7	CPCTR DCPLR 33/47n 0.2"	1
C8	CPCTR DCPLR 33/47n 0.2"	1
C9	CPCTR DCPLR 33/47n 0.2"	1
C10	CPCTR DCPLR 33/47n 0.2"	1
C11	CPCTR DCPLR 33/47n 0.2"	1
C12	CPCTR DCPLR 33/47n 0.2"	1
C13	CPCTR DCPLR 33/47n 0.2"	1
C14	CPCTR DCPLR 33/47n 0.2"	1
C15	CPCTR DCPLR 33/47n 0.2"	1
C16	CPCTR DCPLR 33/47n 0.2"	1
C17	CPCTR DCPLR 33/47n 0.2"	1
C18	CPCTR DCPLR 33/47n 0.2"	1
C19	CPCTR DCPLR 33/47n 0.2"	1
C20	CPCTR DCPLR 33/47n 0.2"	1
C21	CPCTR DCPLR 33/47n 0.2"	1
C22	CPCTR CLASY 10n 250V 20%	1
C23	CPCTR 10N CPLT 30V 80%	1
C24	CPCTR 10N CPLT 30V 80%	1
C25	CPCTR CPLT 33p 30V 2%	1
C26	CPCTR CPLT 10p 30V 2%	1
C27	CPCTR 10N CPLT 30V 80%	1
C28	CPCTR 10N CPLT 30V 80%	1
C29	CPCTR 10U TANT 16V 20%	1
IC1	IC 8391A MCC 28 PLCC	1

Item	Description	Qty
IC2	IC 8392A TRNSCVR 16/0.3"	1
IC3	IC 8390C NIC 68 PLCC	1
IC4	IC 74HC245 CMOS 20/0.3"	1
IC5	IC 74HC245 CMOS 20/0.3"	1
IC6	IC ROM [0727,128 TBP]	1
IC7	IC 74HCT273 CMOS 20/0.3"	1
IC8	IC 74HCT273 CMOS 20/0.3"	1
IC9	IC 74HCT573 CMOS 20/0.3"	1
IC10	IC PAL 1 [0760,200 TBP]	1
IC11	IC 74ACT646 CMOS 20/0.3"	1
IC12	IC 74HCT573 CMOS 20/0.3"	1
IC13	IC 74ACT646 CMOS 20/0.3"	1
IC14	IC PAL 2 [0760,200 TBP]	1
IC15	IC SRAM 32Kx8 100nS 28/6	1
IC16	IC SRAM 32Kx8 100nS 28/6	1
IC17	IC DC/DC CONV 5V TO -9V	1
IC18	IC PAL 3 [0760,200 TBP]	1
IC19	IC PAL 4 [0760,200 TBP]	1
IC20	IC 74HC04 CMOS 14/0.3"	1
IC21	IC 74HC04 CMOS 14/0.3"	1
D1	DIODE IN4150 SI 50V DO35	1
FS1	FUSE 500MA FF AX LEAD LBC	1
TF1	TXF ISO LAN 16/0.3"	1
LK1	NOT FITTED	
LK2	NOT FITTED	
LK3		
LK4		
LK5	CONR 6W WAFR 0.1" ST PCB	3
LK6		
LK7		
LK8		
LK9	NOT FITTED	
LK10	NOT FITTED	
LK11	NOT FITTED	
LK12	NOT FITTED	
LK13	NOT FITTED	
LK14	NOT FITTED	
LK15	NOT FITTED	
LK16	NOT FITTED	
SK1	CONR 15W SKT RA PCB +RFI	1
SK2	CONR BNC SKT RAPCB INSU	1
PL1	CONR 64W PLG RA AC PCB	1
X1	XTAL 20MHZ HC18 20PF P/L	1
	*1 PER BATCH	

SCSI interface card (issue 2+)

Item	Description	Qty
1	BARE SCSI PCB (Iss 2+)	1
2	ASSEMBLY DRAWING	1*
3	CIRCUIT DIAGRAM	1*
6	SCSI PCB BACKPANEL	1
8	PODULE PCB BRACKET (STD)	2
10	CONRD L 50W PLG SCSI TERM SK1	1
13	CONR 2W SHUNT 0.1" LK4,5,6,7	4
15	SKT IC 20/0.3" SUPA IC9,12,14,15,18	5
16	SKT IC 32/0.6" SUPA IC5	1
17	SKT IC 44W PLCC IC16	1
18	SKT IC 52W PLCC IC17	1
21	SCW M2,5x6 PAN HD POSI USE ON ITEM 6	2
22	SCW M3x8 PAN HD POSI Z&P USE ON ITEM 1 AND SK1	2
24	NUT M3 STL FULL Z/PAS USE ON ITEM 22	2
25	WSHR M3 PLN STL Z/PAS USE ON ITEM 22	2
26	WSHR M2,5 PLN STL Z/PASS USE ON ITEM 21	2
28	RIVET POP DOME 3,2D & THK USE ON ITEMS 1 AND 8	2
R1	RES 270R C/MF 5% 0W25	1
R2	RES 68R C/MF 5% 0W25	1
R3	RES 10K C/MF 5% 0W25	1
R4	RES 10R C/MF 5% 0W25	1
R5	RES 10K C/MF 5% 0W25	1
R10	RES 4K7 C/MF 5% 0W25	1
R17	RES 1K5 C/MF 5% 0W25	1
R19	RES 470R C/MF 5% 0W25	1
R21	RES 10K C/MF 5% 0W25	1
R22	RES 10K C/MF 5% 0W25	1
R25	RES 10K C/MF 5% 0W25	1

Item	Description	Qty
C1	CPCTR 33/47n DCPLR 0.2"	1
C2	CPCTR 100u ALEC 25V 20%	1
TO	CPCTR 33/47n DCPLR 0.2"	17
TO	CPCTR 100P CPLT 30V 2%	12
TO	CPCTR 100P CPLT 30V 2%	5
IC1	IC 74HCT273 CMOS 20/0.3"	1
IC2	IC 74HC245 CMOS 20/0.3"	1
IC3	IC 74HCT541 CMOS 20/0.3"	1
IC4	IC 74HC245 CMOS 20/0.3"	1
IC5	IC SCSI EPROM (0727,256)	1
IC6	IC 74HC245 CMOS 20/0.3"	1
IC7	IC 74HCT573 CMOS 20/0.3"	1
IC8	IC 74HC245 CMOS 20/0.3"	1
IC9	IC GAL 2+ (0760,200 TBP)	1
IC10	IC 74HCT541 CMOS 20/0.3"	1
IC11	IC SRAM 32Kx8 100nS 28/0.6	1
IC12	IC GAL 4+ (0760,200 TBP)	1
IC13	IC SRAM 32Kx8 100nS 28/0.6	1
IC14	IC GAL 3+ (0760,200 TBP)	1
IC15	IC GAL 1+ (0760,200 TBP)	1
IC16	IC 33C93A SCSI 44PLCC	1
IC17	IC 71071 DMAC 52PLCC	1
IC18	IC GAL 5+ (0760,200 TBP)	1
TR1	TRANS BC239C NPN TO92 .2"	1
D1	DIODE BYV10-40 SCHOTTKY	1
LK1	CONR 2W WAFR 0.1" ST PCB	1
LK2	CONR 2W WAFR 0.1" ST PCB	1
LK3	CONR 2W WAFR 0.1" ST PCB	1
LK4	CONR 2W WAFR 0.1" ST PCB	1
LK5	CONR 2W WAFR 0.1" ST PCB	1
LK6	CONR 2W WAFR 0.1" ST PCB	1
LK7	CONR 2W WAFR 0.1" ST PCB	1
LK8	NOT FITTED	
LK9	NOT FITTED	
LK10	CONR 2W WAFR 0.1" ST PCB	1
SK1	CONRD L 50W SKT RA PCB M3	1
PL1	CONR 64W PLG RA AC PCB	1
PL2	CONR 50W BOX IDC LP ST	1
FS1	FUSE 1A0 F 8.7x2.54mm LBC	1

*1 PER BATCH

Appendix A - Mouse test jig template

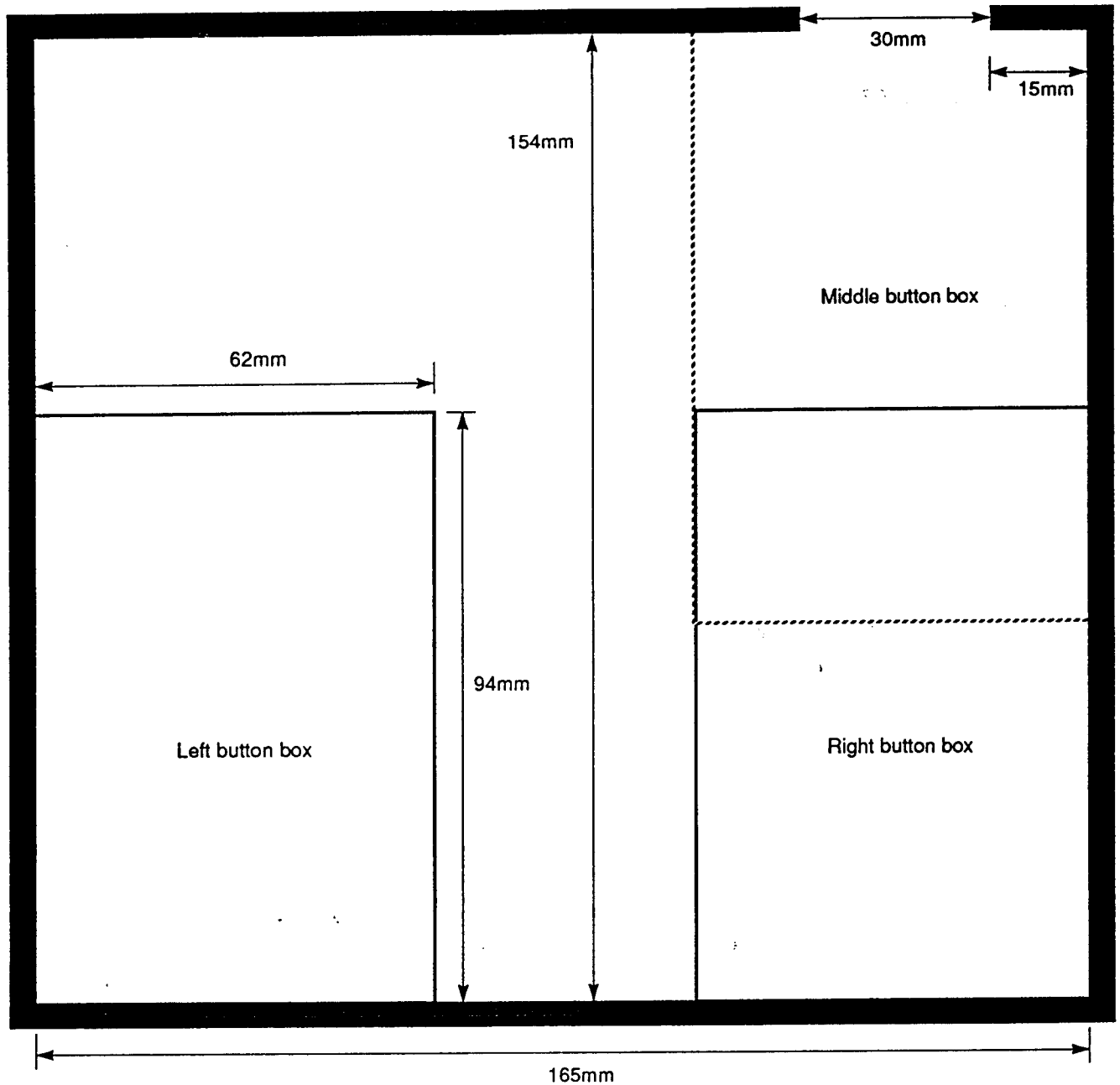

You can use the template above as a test jig, but take care that the mouse does not slip on the paper. You can construct a better jig as follows:

- 1 Using wood or metal strips, construct a test jig with the dimensions shown in the template (plan view) above.
- 2 Secure the test jig to a firm, flat, horizontal, non-slip surface.
- 3 Mark out the three button boxes shown on the template.

Notes:

- The INSIDE dimensions of the jig are important.
- The sides of the jig should be LESS than 5mm high.
- The Middle and Right button boxes overlap.

Mouse in middle button box

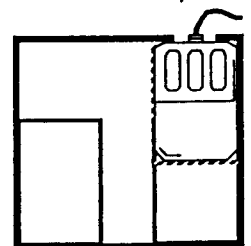

Appendix B - Ethernet test feedback leads

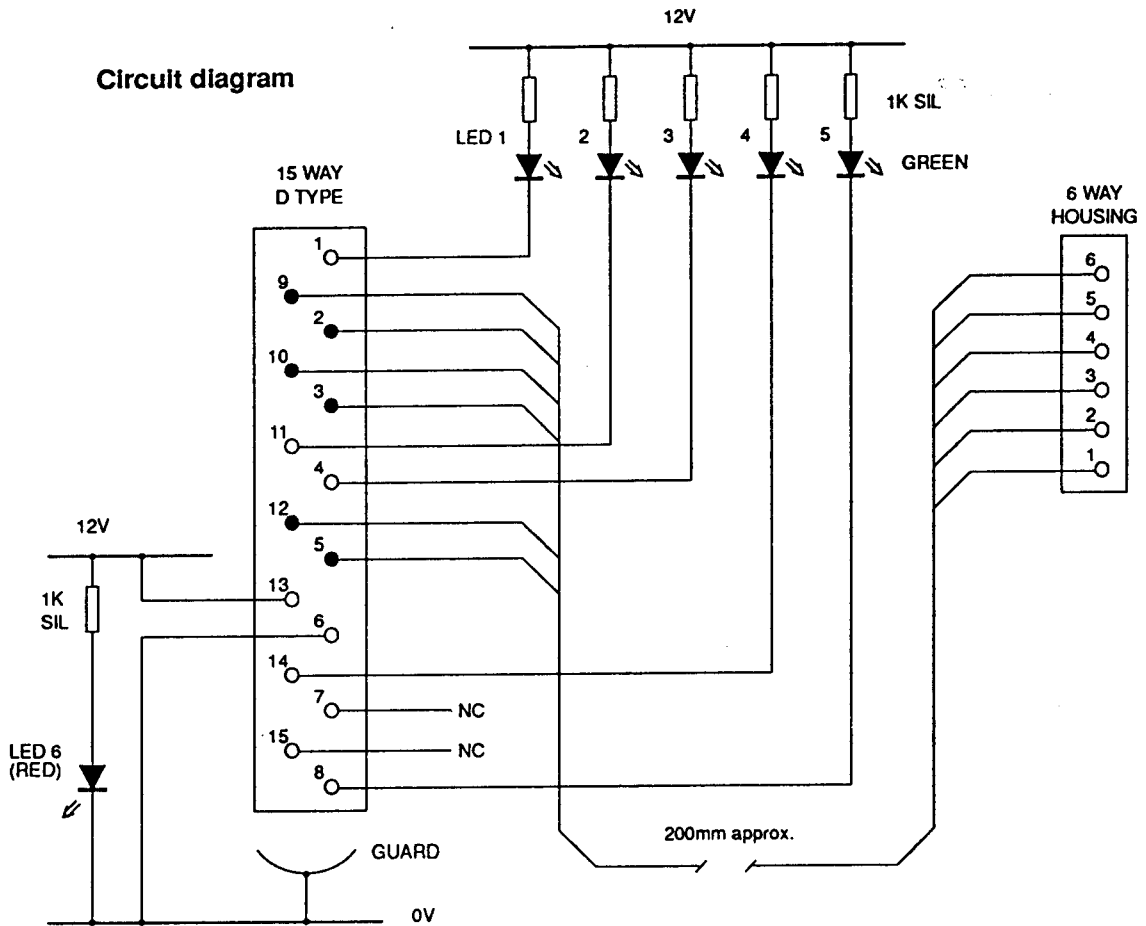

Pin mappings for Ethernet II and Ethernet I test feedback leads

6 WAY ETHERNET II		6 WAY ETHERNET I		D TYPE CONNECTOR
PIN	SIGNAL	PIN	SIGNAL	PIN
1	ECD	5	ETRMT	2
2	ERX	3	ETRMT	5
3	ERX	4	ERCV	12
4	ETX	1	ERCV	3
5	ECD	6	ECLSN	9
6	ETX	2	ECLSN	10

Parts list

QTY	DESCRIPTION	RS CODE
1	RESISTOR NETWORK SIL 1K	RS149 - 262
1	LED ARRAY GREEN 5W	RS 588 - 235
1	COVER D 15W	RS469 - 572
1	PLG D SCRIN 15W	RS473 - 903
1	LED RED	RS587 - 125
1	MOLEX SHELL 6W	RS467 - 633*
6	MOLEX CRIMPS	RS467 - 598

*CUT DOWN FROM 10 WAY

See over for instructions on constructing the leads.

Constructing the test feedback leads

One solution is to incorporate the LEDs in the cover of the 15-way D-type plug. This involves modifying the plug's cover, but makes for a neat, compact test lead with no unnecessary trailing wires.

The finished lead should look like that shown in the figure below.

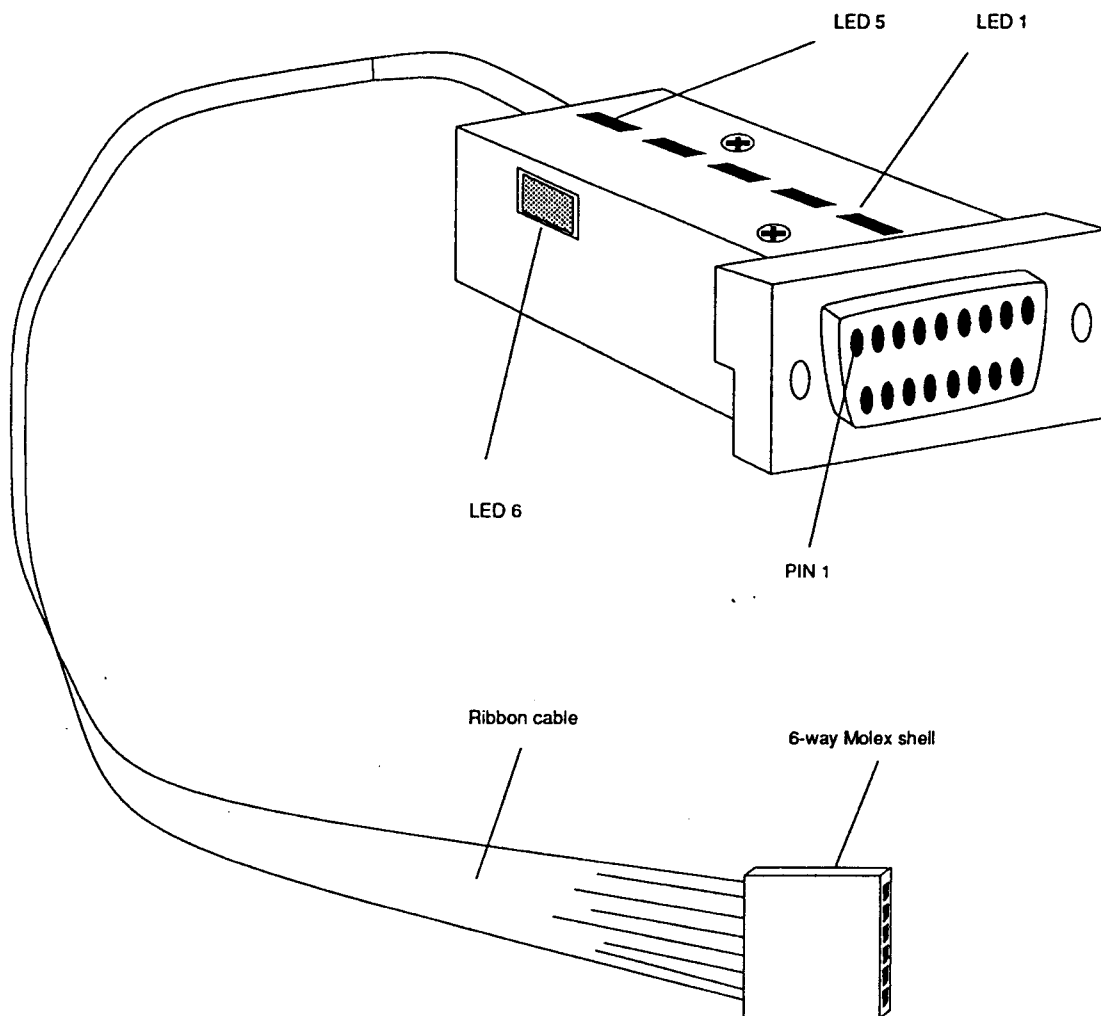

Appendix C - Serial port loopback plug

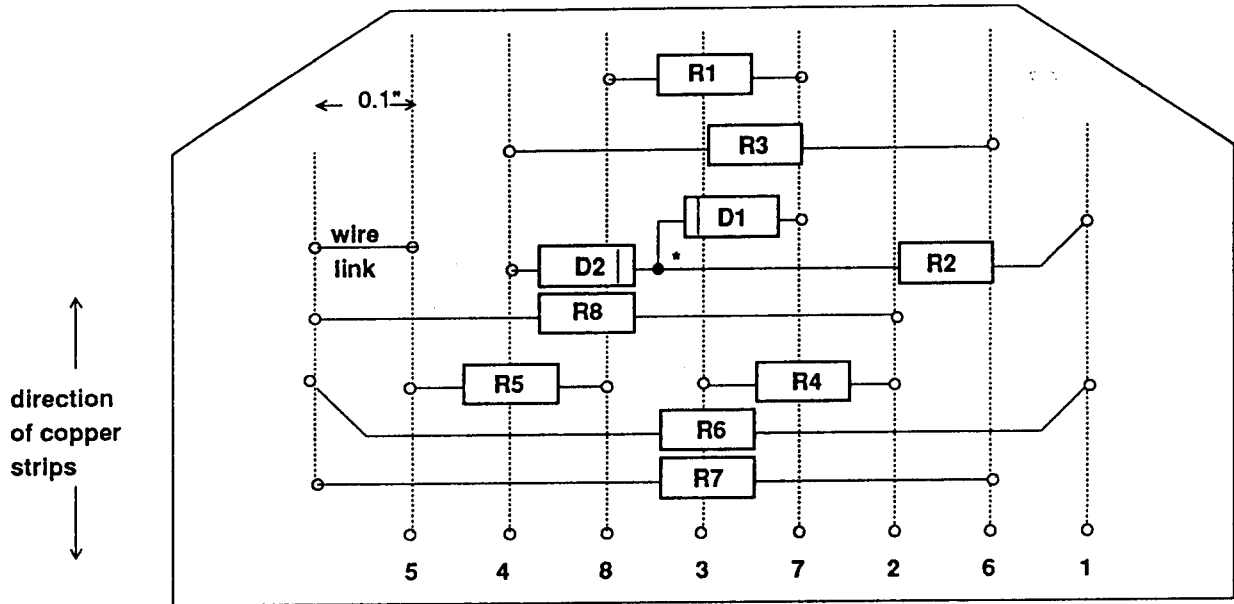

○ hole

* components join above the board surface

Assembly notes

Assemble the components onto Veroboard, and fit item 5 (the shell) to protect the assembly

Item	Part no.	Description	Qty
1	0276,081	CIRCUIT & ASSEMBLY DRAWING	1*
3	0800,288	CONR 9W SCKT 'D' ST MS SB	1
5	0800,991	CONR 9W SHELL 'D' + SCREWS	1
R1	0502,122	RES 1K2 C/MF 5% 0W25	1
R2	0502,122	RES 1K2 C/MF 5% 0W25	1
R3	0502,122	RES 1K2 C/MF 5% 0W25	1
R4	0502,122	RES 1K2 C/MF 5% 0W25	1
R5	0502,472	RES 4K7 C/MF 5% 0W25	1
R6			N/F
R7	0502,472	RES 4K7 C/MF 5% 0W25	1
R8	0502,472	RES 4K7 C/MF 5% 0W25	1
D1	0790,085	DIODE BAT85 SBL	1
D1	0790,085	DIODE BAT85 SBL	1

* per batch

Appendix D - Earth continuity testing

Equipment required

An earth continuity tester capable of sourcing 25A derived from an AC source with a no-load voltage not exceeding 12V.

It is recommended that the calibration and operation of the instrument be checked frequently enough to ensure its accuracy.

Test Procedure

The test should be performed on a fully assembled computer.

Using the Earth continuity tester, check the continuity between the power supply cord plug earth/ground pin and the following points:-

- 1 the rear panel internal expansion card fixing screws
- 2 fixing bolts for
 - printer/parallel port (D-type)
 - Analogue RGB port (D-type)
 - any other expansion cards (eg SCSI).

The resistance measured between the earth pin and each of the above test points shall not exceed 0.15 Ω . This value includes an allowance for the resistance of the mains cable. The duration of each test shall not exceed 10 seconds. No waiting period between tests is necessary.

DANGER

THE FOLLOWING TESTS INVOLVE HIGH CURRENTS BUT LOW VOLTAGES. ALL NECESSARY PRECAUTIONS MUST BE TAKEN TO ENSURE OPERATOR SAFETY DURING TESTING.

DANGER

SWITCH OFF THE COMPUTER, DISCONNECT IT FROM THE MAINS SUPPLY, AND DISCONNECT ANY PERIPHERALS BEFORE CARRYING OUT THIS TEST.

Earth continuity test points

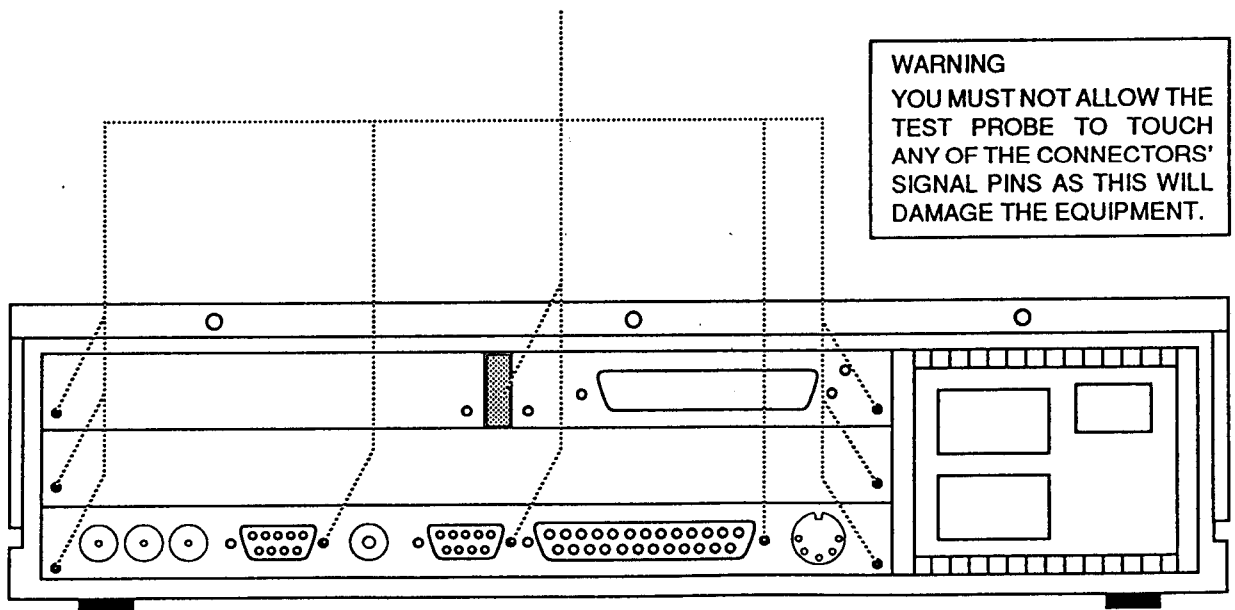

WARNING

YOU MUST NOT ALLOW THE TEST PROBE TO TOUCH ANY OF THE CONNECTORS' SIGNAL PINS AS THIS WILL DAMAGE THE EQUIPMENT.

Appendix E - DC Insulation testing - class 1

Equipment required

An appliance tester or an insulation tester that provides 500V DC ONLY.

Note that the computer contains RFI capacitors on the PSU input.

It is recommended that the calibration and operation of the instrument be checked frequently enough to ensure its accuracy.

DANGER
 THE FOLLOWING TEST INVOLVES HIGH VOLTAGES. ALL NECESSARY PRECAUTIONS MUST BE TAKEN TO ENSURE OPERATOR SAFETY DURING TESTING.

DANGER
 SWITCH OFF THE COMPUTER, DISCONNECT IT FROM THE MAINS SUPPLY, AND DISCONNECT ANY EXTERNAL PERIPHERALS AND EXTERNAL CONNECTIONS BEFORE CARRYING OUT THIS TEST.

Before testing

Check the mains lead and plug for any physical damage and replace if necessary.

Test Procedure

The test should be performed on a fully assembled computer.

- 1 Insert the mains lead either into an appliance tester, or into an adaptor, as shown below.
- 2 Apply the test voltage for 1 (ONE) MINUTE and then measure the resistance.
- 3 Pass level: GREATER than 2 (TWO) MΩ.

Testing with an insulation tester

